

Methods to Improve Freight Performance, Reliability, and Bottlenecks Workshop

March 21, 2022

Jeff Purdy
Federal Highway Administration
Office of Operations
Freight Management and Operations



Source: FHWA



U.S. Department of Transportation
Federal Highway Administration

Disclaimers



U.S. Department of Transportation
Federal Highway Administration

The U.S. Government does not endorse products or manufacturers. Trademarks or manufacturers' names appear in this presentation only because they are considered essential to the objective of the document.

This presentation was created and is being co-presented by both FHWA and other entities. The views and opinions expressed in this presentation are the presenters' and do not necessarily reflect those of FHWA or USDOT. The contents do not necessarily reflect the official policy of the Department of Transportation.

Agenda



U.S. Department of Transportation
Federal Highway Administration

- Project overview
- Freight mobility and reliability performance measures, data, and methodologies
- Toolbox of solutions
- Case studies
- Next steps



Project Overview

Project Objectives

Provide strategies for improving Truck Travel Time Reliability (TTTR) and mobility at truck freight bottlenecks

- Transportation System Management and Operations (TSMO)
- Freight-related capacity improvements
- Addressing congestion at truck freight bottlenecks
- Monitoring effectiveness
- Performance-based planning and programming process
- Congestion management process



U.S. Department of Transportation
Federal Highway Administration

Sources of Disruption Nationwide 2019

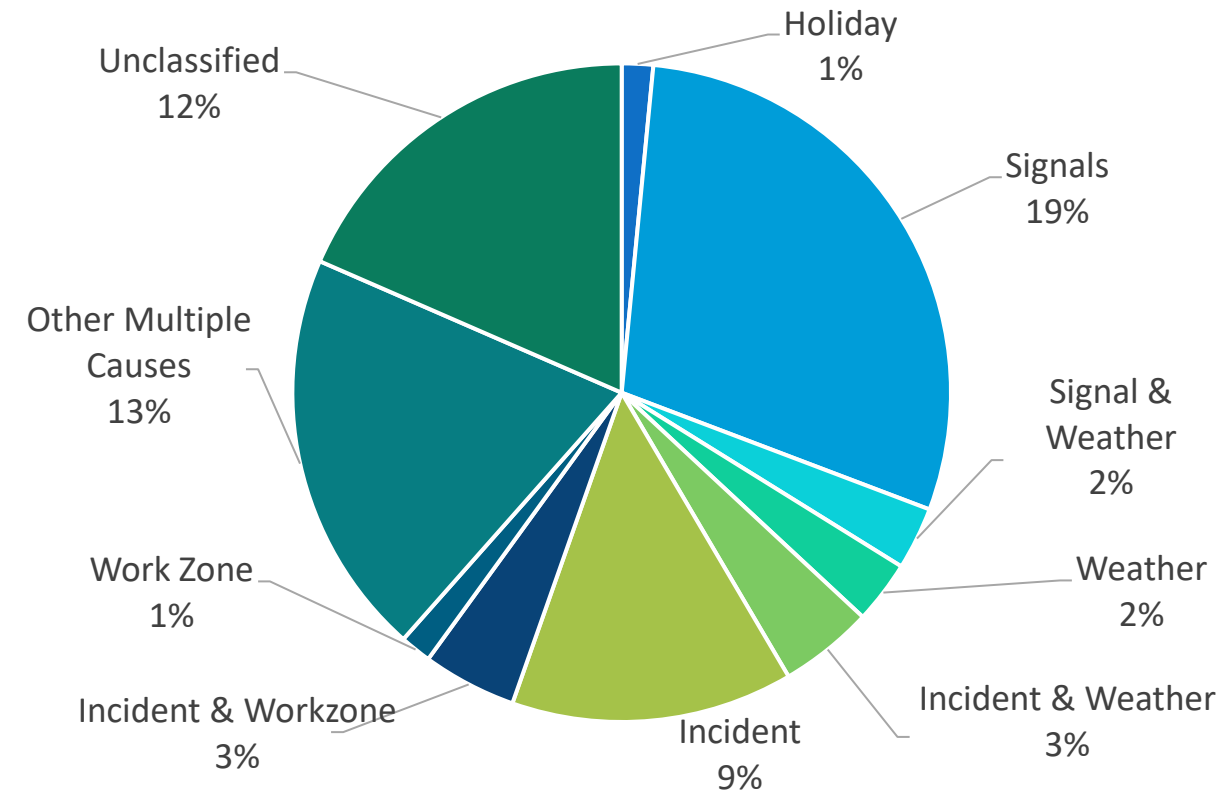

Source: Regional Integrated Transportation Information System (RITIS) 2019



Freight Mobility and Reliability Performance Measures, Data, and Methodologies

Mobility Performance Measures



U.S. Department of Transportation
Federal Highway Administration

Observations reflect information in performance reports and literature

- **TTTR Measure** - National performance measure used to assess freight movement on the Interstate
- **Other Mobility Measures**- 85 percent of all States use other freight mobility performance measures in addition to the TTTR Measure

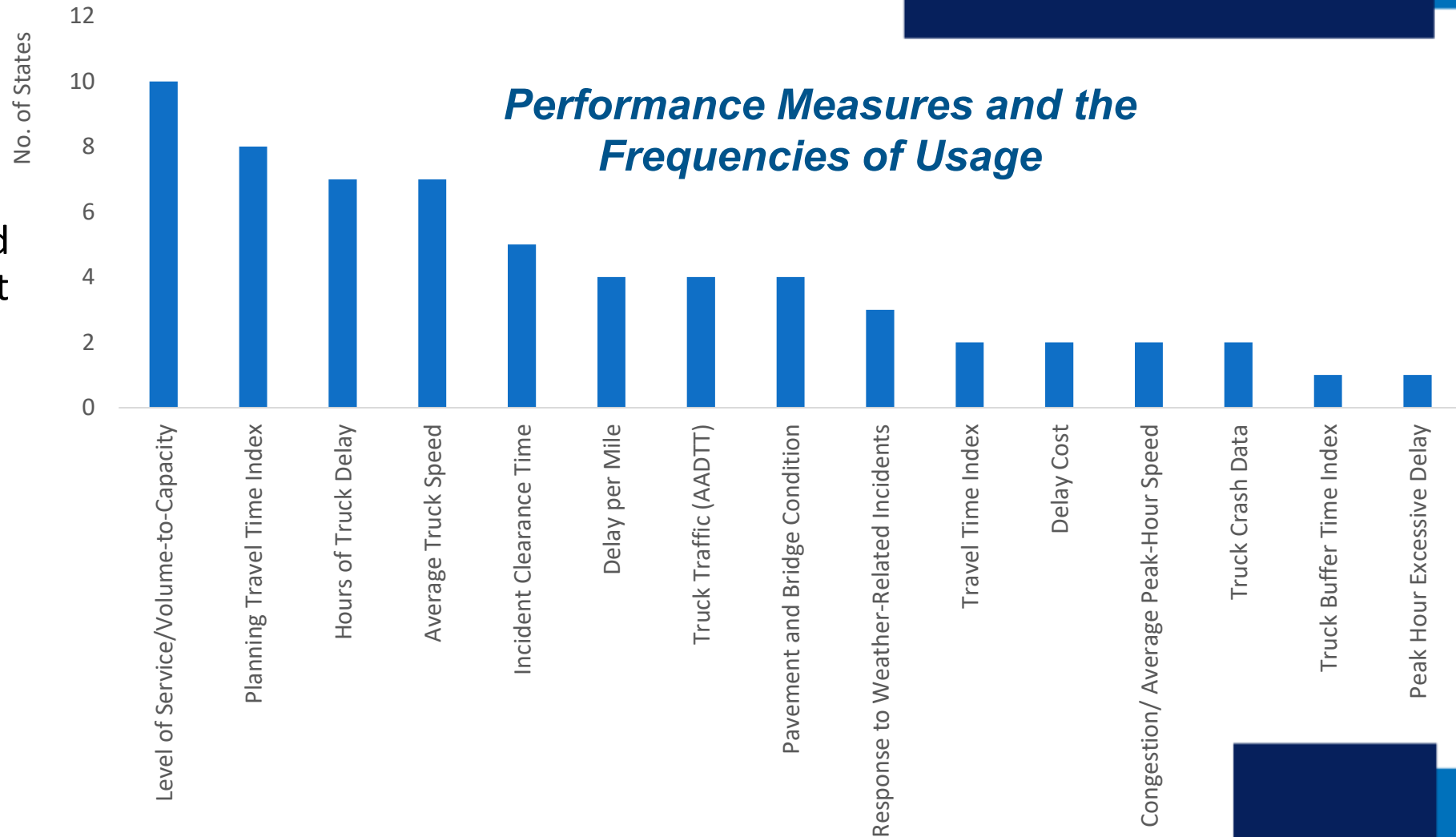

(*) All US States, District of Columbia, and Puerto Rico

Data Sources and Tools for Measuring the TTTR Index



U.S. Department of Transportation
Federal Highway Administration

- National Performance Management Research Data Set (NPMRDS) was the primary data source used by States
- Sixteen States incorporated additional vehicle probe data from third-party provider into TTTR analysis
- Three State Departments of Transportation (DOTs) used third-party data source
- Some States used data platforms to access NPMRDS and third-party speed/travel time data and to measure the TTTR index

Performance Measures and the Frequencies of Usage

Data Sources Used by the States	No. of States
NPMRDS data as primary source	28
NPMRDS and incorporated data from a third-party source	16
Rely primarily on a third-party data source	3
Rely primarily on internal data source	1
Not reporting data source	3

Source: State biennial performance reports, 2017 & 2019

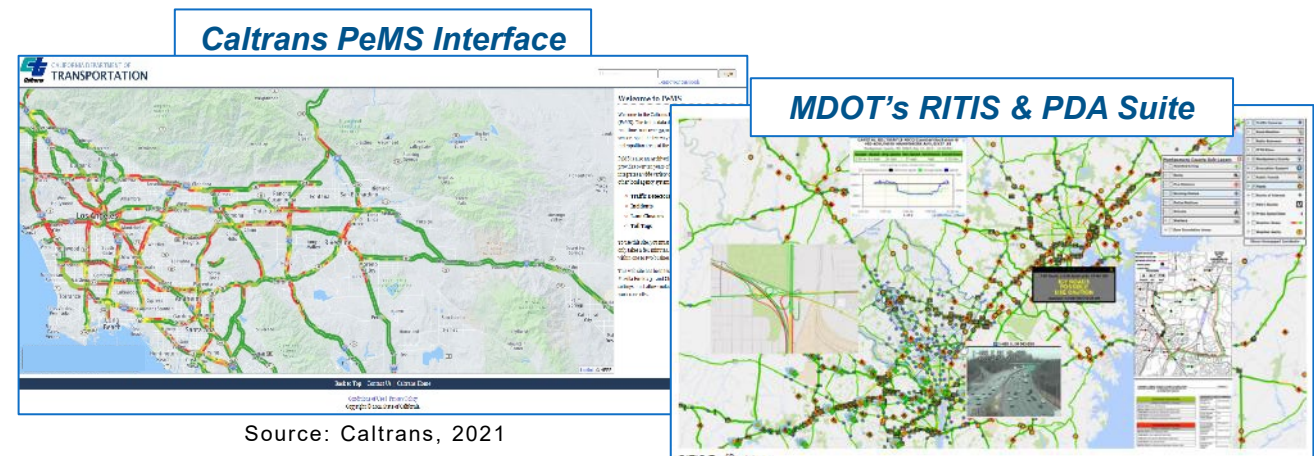

Source: Caltrans, 2021

Source: MDOT, 2021

Freight Bottleneck Analysis and Reporting



U.S. Department of Transportation
Federal Highway Administration

- The number of truck bottlenecks identified by States varies significantly, from no identified bottlenecks in South Dakota, to over 700 bottlenecks in Illinois
- On average, 60 truck bottlenecks were identified by each State
- The median number of bottlenecks identified was 19
- States identified bottlenecks along a combination of roadways

Functional Classification of Bottleneck Segments

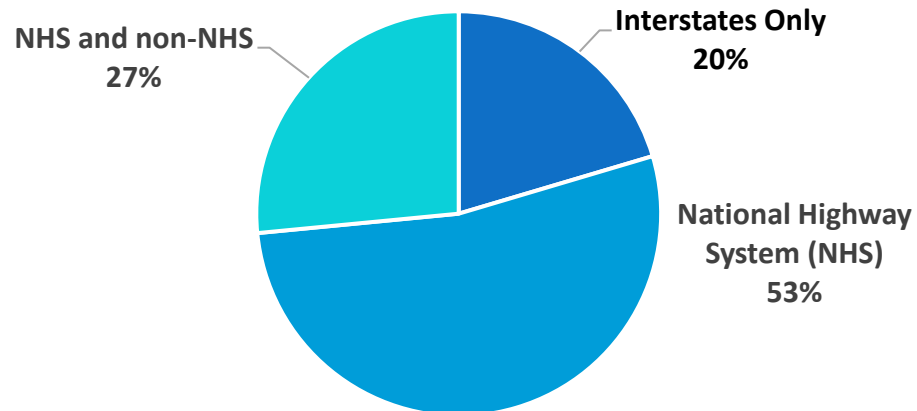

Source: States' biennial performance reports, 2017 and 2019

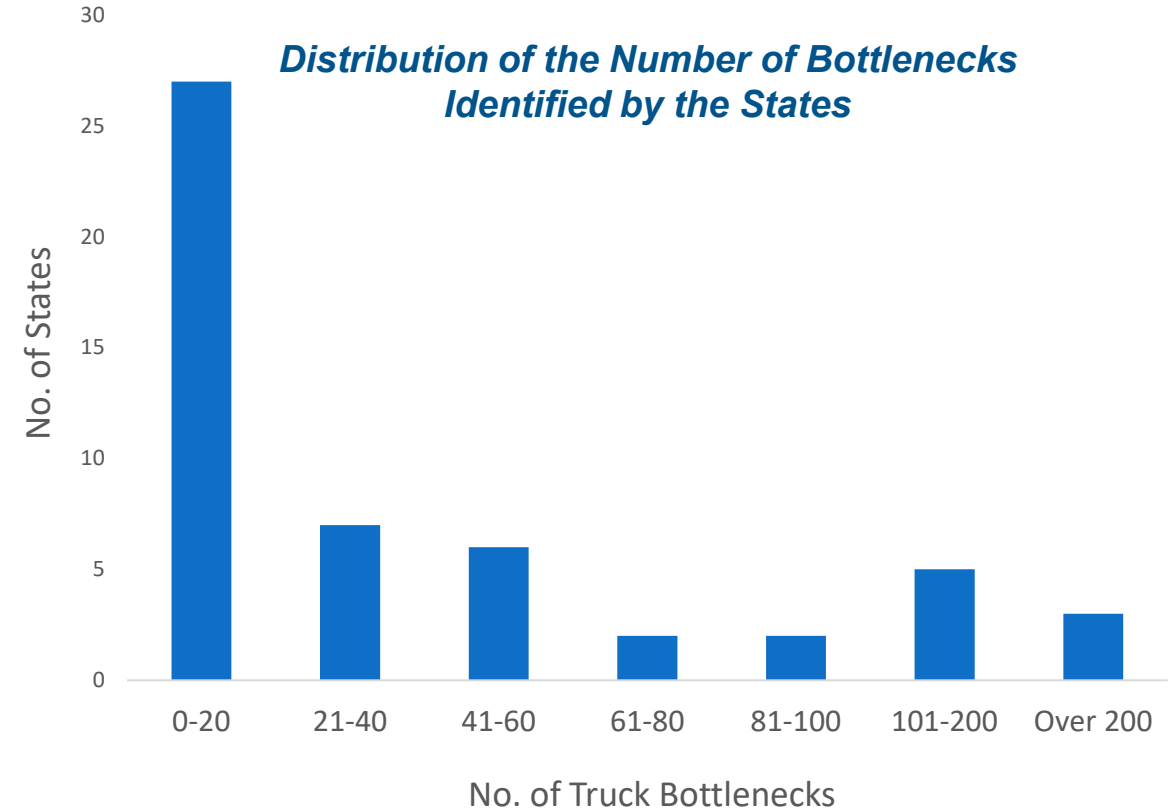

Source: States' biennial performance reports, 2017 and 2019

Bottleneck Analysis Data and Methodologies



U.S. Department of Transportation
Federal Highway Administration

- Two-thirds of States used NPMRDS data to calculate delay
- 16 States relied on other truck GPS data, infrastructure condition data, commodity flow data, and crash data
- Caltrans used its own speed data

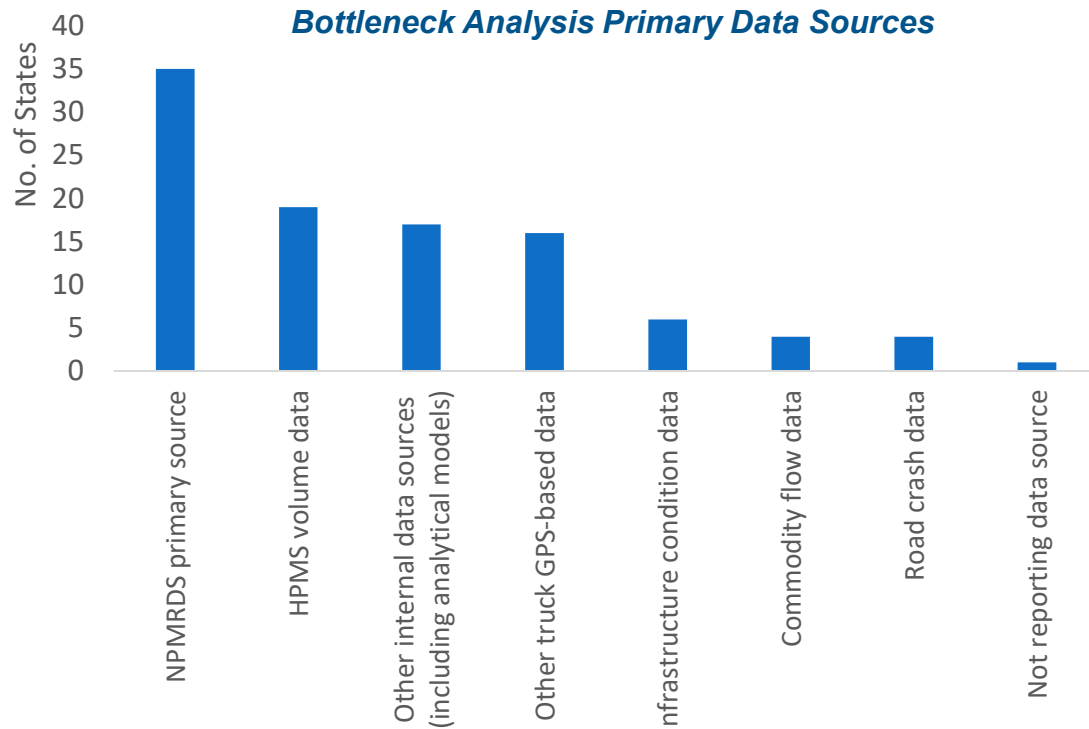

Source: States' biennial performance reports, 2017 & 2019

Bottleneck Analysis Methodologies

Main Measure	Measures used in Conjunction	No. of States
Delay per Mile	TTTR Index	8
Delay per Mile	Truck percent of total traffic	8
Delay per Mile	Planning Time Index	4
Delay per Mile	Truck crash rates	3
Delay per Mile	Level of service	2
Delay per Mile	Infrastructure characteristics	2
Travel Time Reliability	Volume to capacity ratio	5
Travel Time Reliability	Truck percent of total traffic	2
Travel Time Reliability	Duration/frequency of congestion	2
Travel Time Reliability	Truck travel speed profiles	2
Travel Time Reliability	Crash and weather trends	3
Travel Time Reliability	Road geometric design	1
Volume to Capacity Ratio	No other measure	4
Volume to Capacity Ratio	Delay per mile	1
Volume to Capacity Ratio	Infrastructure design	1
Volume to Capacity Ratio	Crash and weather trends	1
Level of Service	No other measure	1
Infrastructure	No other measure	2

Source: States' biennial performance reports, 2017 & 2019

Collaborative Efforts to Identify Freight Bottlenecks



U.S. Department of Transportation
Federal Highway Administration

- Majority of States reporting on truck bottlenecks used **stakeholder engagement** to validate their bottleneck analysis results
- Several States highlighted their regional partnership efforts for addressing bottlenecks

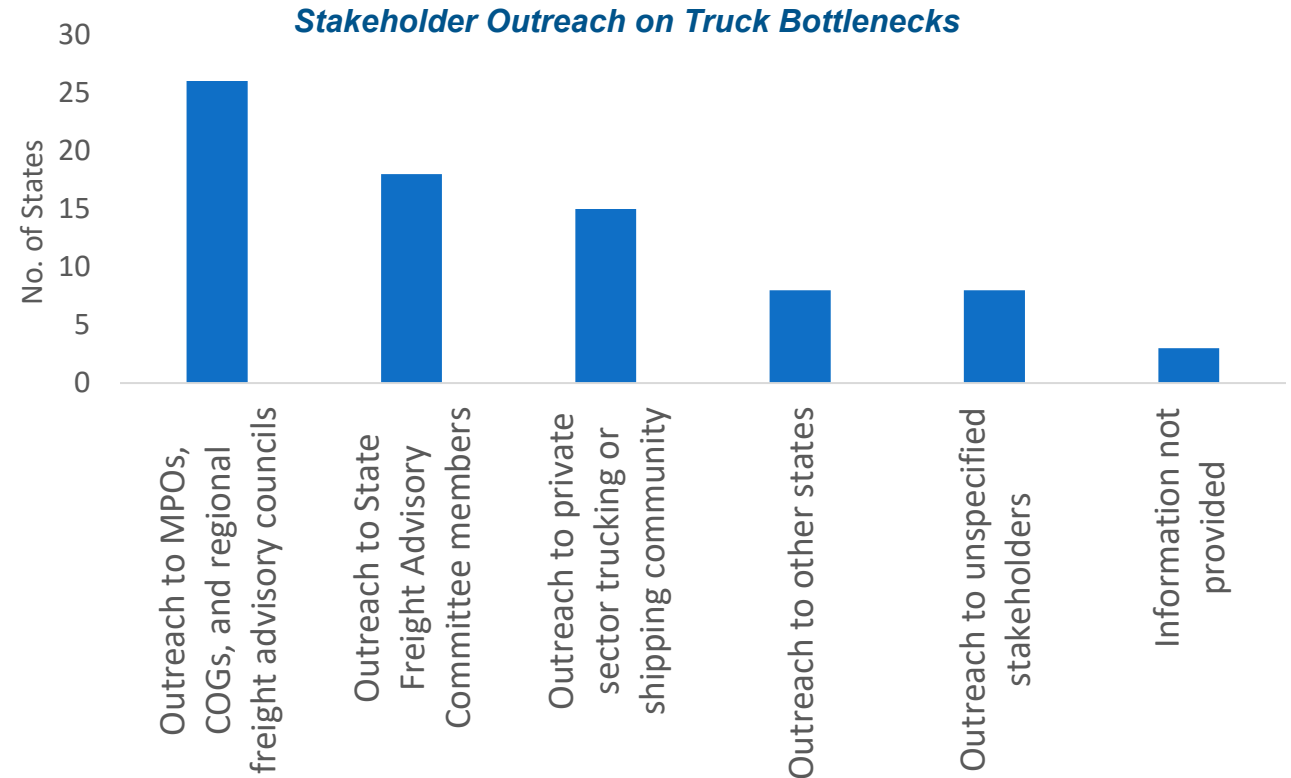

Source: States' biennial performance reports, 2017 and 2019

Truck Bottleneck Mitigation and Decision-Making Activities



U.S. Department of Transportation
Federal Highway Administration

- 24 States had measurement programs mentioned in their bottleneck submittals, State freight plans, or related documents
- Truck bottleneck analysis was also used to prioritize improvement projects
- Majority of States reported ongoing outreach with State Freight Advisory Committees to continue dialogue about locations and performance of truck bottlenecks

Use of Truck Bottleneck Information in Decision Making



Source: States' biennial performance reports, 2017 and 2019

Frequency of States Citing Truck Bottleneck Improvement Project Types

Improvement Project	No. of States
Road widening/capacity expansion	26
Resurfacing/pavement rehabilitation/reconstruction	23
Bridge/tunnel improvements	22
ITS implementation	19
Interchange improvements	15
Ramp improvements	12
Truck parking improvements	10
Signal programs	10

Source: States' biennial performance reports, 2017 and 2019

Peer Exchange – Summary of Mobility Performance Measure Discussion (10/19/2021)



U.S. Department of Transportation
Federal Highway Administration

- **Variation In Approaches and Common Measures** - States are using common measures such as delay per mile and cost of delay to link freight performance to economic development. Less focus on sustainability and other social impacts.
- **Visualization** – Is used by some state DOTs as a way to communicate bottlenecks.
- **Highway and Multimodal** - Most States focused on highway freight performance; some States like Iowa and Louisiana conduct multimodal performance benchmarking.
- **Grouping of Bottlenecks Scaled to the Size of the State** - Bottlenecks that reflect freight mobility conditions within the state and mix of urban and rural areas.
- **Prioritizing Bottlenecks** - Virginia uses a seven-point scale incorporating intensity and truck volume to feed decision-making process.
- **Avoiding Silos** - Working across agencies (collaborating with bridge, maintenance, etc.)
- **Methodologies for Temporal Visibility** - States developing methodologies and tools that incorporate Federal Highway Administration (FHWA) methods and measures and other sources and tracking over time, often as part of the State freight plan update cycle.

Peer Exchange – Summary of Solution Discussion (10/19/2021)



U.S. Department of Transportation
Federal Highway Administration

- **Tools to Monitor Mobility**

- Focus on freight data innovations and fusing existing data to improve mobility planning and management
- Use of online/interactive platforms to enable mobility monitoring programs

- **Strategies to Improve Mobility**

- Investigating the cause of recurring and non-recurring congestion to identify issues
- Establishing feedback loops with the internal and external stakeholders
- Deploying communications and leveraging applications
- Focus on project implementation phase after completing planning efforts
- Safety improvements to mitigate non-recurring delays
- Ramp metering/variable speed limits (both may save money on capacity)
- **Transportation Systems Management and Operations (TSMO) requires a “Portfolio” or “Programmatic” approach**

Peer Exchange – Summary of Solution Discussion (continued)



U.S. Department of Transportation
Federal Highway Administration

• Challenges

- Funding and tradeoffs (which strategies, data, systems have the best return on investment)
- Political challenges and role of government
- Data are essential but not inexpensive
- Establishing common understanding of how to measure and communicate operational issues (e.g., regions within a State may interpret incidents differently)



Toolbox of Solutions

Toolbox of Solutions



U.S. Department of Transportation
Federal Highway Administration

Transportation Systems Management and Operations

Freight Information Technology



Freight Planning and Management

Intermodal Transportation

Transportation Systems Management and Operations (TSMO)



U.S. Department of Transportation
Federal Highway Administration

- TSMO strategies focus on operational improvements that maximize operational performance of the existing transportation system
- Goal is to get the most performance out of the transportation facilities already in place
- Approaches performance from a systems perspective
- Spans corridors, jurisdictions, modes, and agencies
- Helps agencies balance supply and demand on the system and provide flexible solutions to manage dynamic conditions
- Can complement capacity projects or provide lower cost, faster alternatives in some cases

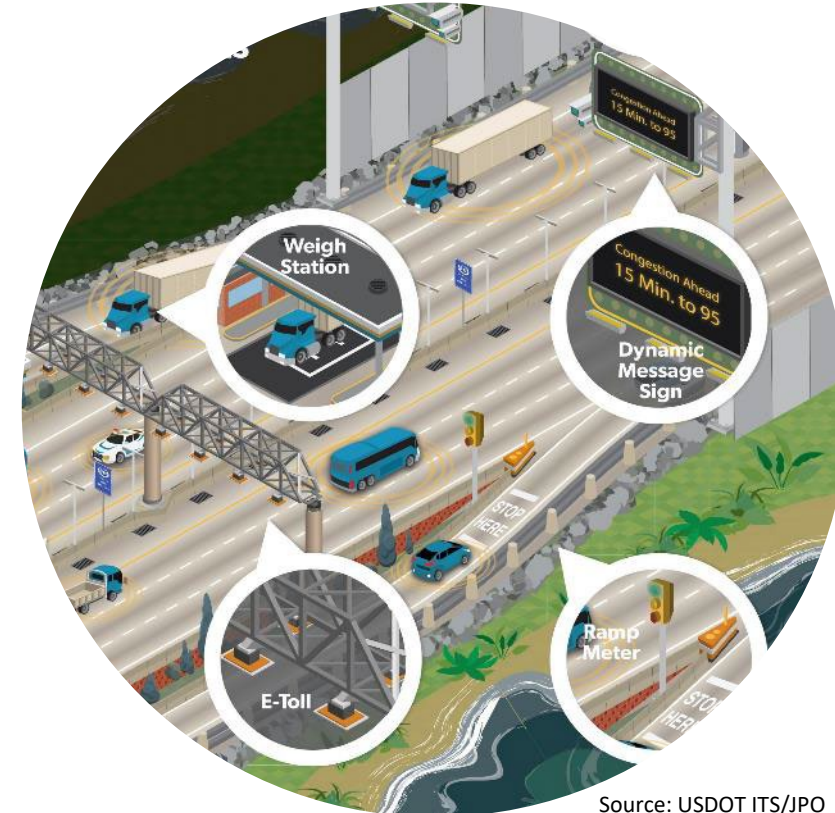

Source: USDOT ITS/JPO

Freight Traveler Information Systems



U.S. Department of Transportation
Federal Highway Administration

- Freight-Specific Dynamic Travel Planning and Performance
 - Integrates data on wait times at ports, traffic conditions, incident alerts, work zones, and routing restrictions
 - Benefits:
 - Real-time information and dynamic routing for drivers
 - Adaptive communication between drayage company, drivers, and port terminals
 - Performance monitoring elements
- Intermodal Drayage Operations Optimization
 - Combines container load matching and freight information exchange systems to fully optimize drayage operations
 - Benefits:
 - Individual trucks are assigned best time windows for pick-up or drop-off
 - Utilizes travel information and information on port terminal conditions to optimize operations
 - Minimizes wasted miles and spreads truck arrivals at port terminals throughout the day

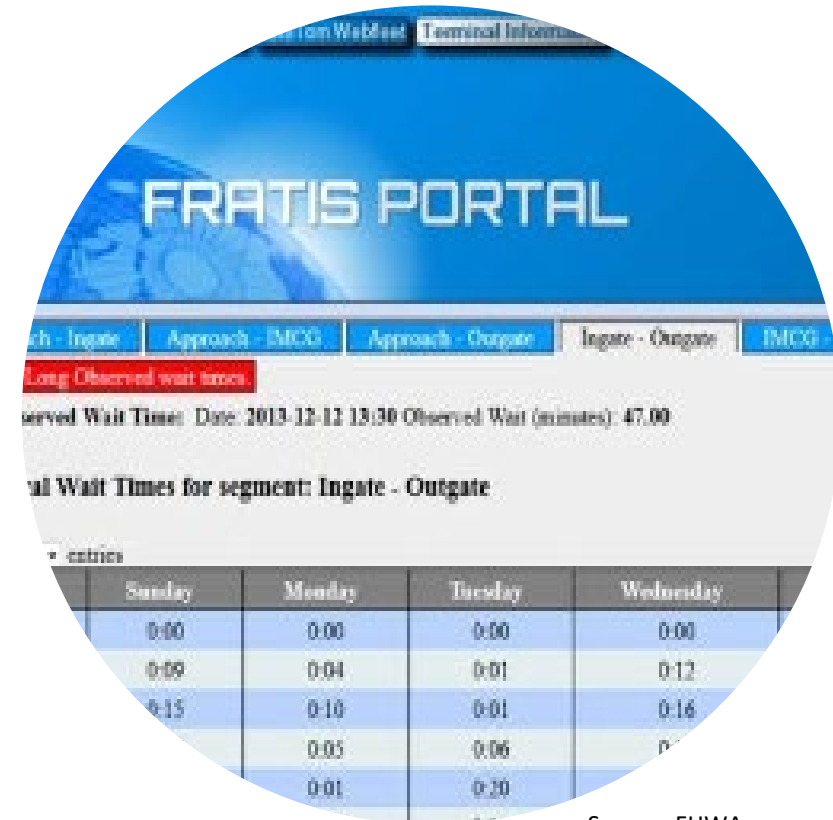

Source: FHWA

Electronic Credentialing and Permitting

- Enables motor carriers to electronically apply, pay, and receive oversized/overweight permits, International Registration Plan (IRP) and International Fuel Tax Agreement (IFTA) credentials
- Benefits:
 - Systems are available 24 hours a day and reduce costs and time associated with paper-based systems
 - When coupled with roadside electronic screening, trucks can be identified at highway speeds, which:
 - Allows legal trucks to bypass weigh stations
 - Provides inspectors real-time data to decide whether to call in vehicles
 - Controls volume of traffic through and around weigh stations
 - Safety information exchange allows electronic collection and exchange of safety performance information among states, federal agencies, and motor carriers



U.S. Department of Transportation
Federal Highway Administration



One Stop Credentialing and Registration

OSCAR

[FAQs](#) | [Privacy](#) | [Security](#) | [Contact Us](#)

One Stop Credentialing and Registration

Log In

Business Type <Select Business Type> ▾

USDOT #

NYS Tax ID #

Password

By clicking Log In, you agree to the [Terms and Conditions](#) and certify all information to the best of your knowledge.

USDOT # - Enter your USDOT Number.

NYS Tax ID # - Enter your FEIN (federal employer identification number), including applicable. Enter only numbers and/or letters (no dashes), must be 9 to 11 characters.

Password - Enter your current OSCAR password. If you have not yet enrolled or do not know your password, please contact the helpline at (518) 457-5735.

Source: New York State DMV

Smart Roadside Commercial Motor Vehicle Monitoring

- Roadside technologies that collect information on trucks traveling at highway speeds
- Automated USDOT Number recognition systems and license plate readers for commercial motor vehicle screening
- Thermal inspection systems scan axle sets to identify unsafe equipment (e.g., inoperative brakes or under-inflated tires)
- LiDAR sensors scan vehicle and load length, width, and height to confirm vehicle is within size limits
- Mobile website developed for law enforcement
- Mobile app developed for truck drivers to notify them to pull into or bypass weigh station
- Benefits:
 - Collects truck data and screens trucks at highway speeds
 - Facilitates more efficient, dynamic inspection and enforcement



U.S. Department of Transportation
Federal Highway Administration

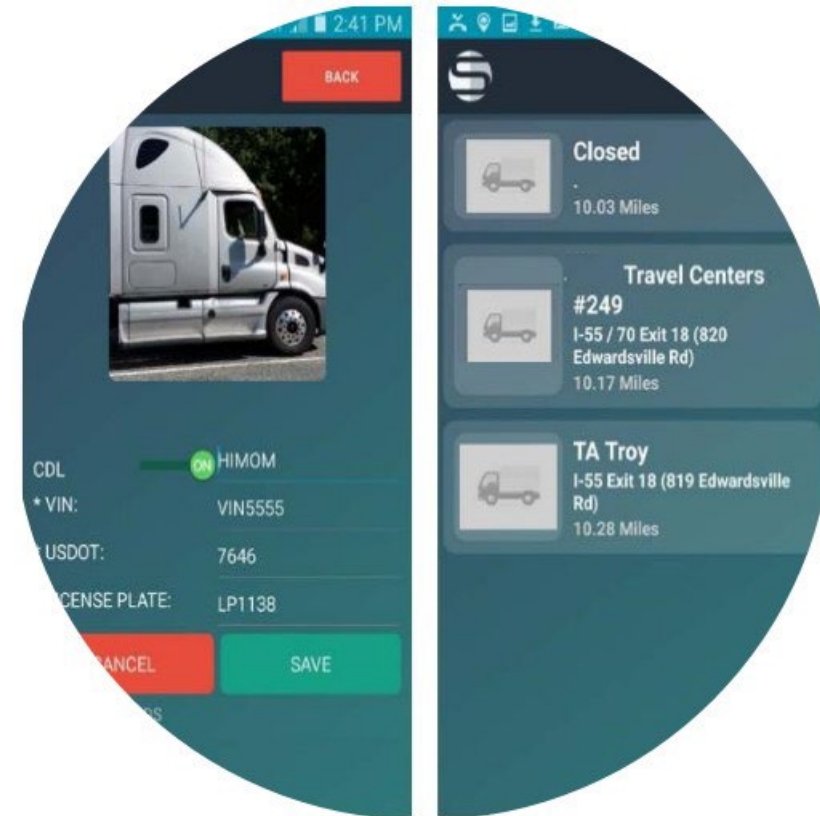

Source: FHWA

Weigh-in-Motion (WIM)

- Sensors collect data on truck and axle weight, length, speed, and travel date/time
- Used for enforcement, data collection, freight and congestion planning, pavement studies, crash rate calculations, and corridor management
- Used to pre-screen trucks as they enter weigh station to assist the processing of commercial vehicles
- Benefits:
 - Allows for continuous measurement of trucks traveling on the highway, without diverting or stopping them
- ***Caltrans Truck Activity Monitoring System (TAMS):*** Inductive signature-based truck body classification models deployed at WIM and inductive loop detector sites



U.S. Department of Transportation
Federal Highway Administration

WIM Applications

- Bypass WIM systems installed upstream of weigh stations
- In-station WIM systems used to pre-screen trucks
- WIM used in conjunction with vehicle screening systems
- Mainline data WIM systems used for data collection

Truck Queue Management / Appointment Systems at Ports



U.S. Department of Transportation
Federal Highway Administration

- Truck Reservation Systems (TRS)
 - Allow drayage firms to make efficient dispatching plans with reduced driver queue times
 - Allow marine terminals control workloads, thereby reducing drayage congestion and delay
- Port of Virginia PRO-PASS TRS
 - Carriers calling at the port's Norfolk International Terminal or Virginia International Gateway must have a reservation
 - Truck turn times reduced up to 32%



From the left side menu, navigate to Reservations and Reservation Moves.

On this page you will see a search box where you can search for existing reservations.

Here you will see the status for each appointment. Enter your criteria and select Search. Reservation matching your criteria will be listed

When confirmed is listed in green – the reservation is confirmed and all of the required information has been provided. In other words, a green confirmed appointment is good to go.

Blue indicates the reservation need to be confirmed by the Terminal.
Yellow indicates the reservation has outstanding items that must be addressed prior to arrival at the gate.

The screenshot shows a web application interface for 'RESERVATION MOVES'. It includes a search box at the top, a table of reservation moves, and a sidebar with navigation options. The table has columns for 'Table #', 'Status', 'User', 'Start Date', and 'End Date'. The status column contains various colored indicators (green, blue, yellow) and text labels like 'Confirmed', 'Pending', and 'Outstanding'. A callout box points to an exclamation mark icon in the status column, indicating that clicking on it reveals additional details for that reservation.

By clicking on the exclamation points you can see what additional items are needed to move the appointment to a green status.

Source: Port of Virginia

Truck Parking Information Management Systems

- Disseminate real-time parking utilization information to maximize use of existing sites
- Variety of sensing technology provides space occupancy, entrance/exit counts, or area-wide truck identification
 - Video technology
 - In-ground sensors
 - Infrared sensors
 - Above-ground radar
 - Side laser scanner
- Predictive algorithms to estimate utilization by time and day
- Data disseminated through
 - Roadside dynamic message signs
 - In-vehicle technology
 - Smartphone applications
 - 511 websites



U.S. Department of Transportation
Federal Highway Administration



Source: MDOT

Border Wait Time Information



U.S. Department of Transportation
Federal Highway Administration

Niagara International Transportation Technology Coalition (NITTEC), New York regional border wait time data

- Bluetooth readers along border crossing bridges and approaching roadways capture the speed and travel time data to calculate
 - **Actual Delay** - Difference between travel time and the known free flow travel time
 - **Current Delay** - A smoothed delay measure of several data reads; this is the measure that is reported to the public
- Congestion decreased as travelers make informed decisions about where and when to cross the border
- During severe snow events, local police use NITTEC's clearinghouse to direct truck drivers to temporary parking areas

Intelligent and Efficient Border Crossing Program at Otay Mesa East, California

- USDOT working with Federal, State, and local partners
- Developing plan for tolling system using dynamic pricing

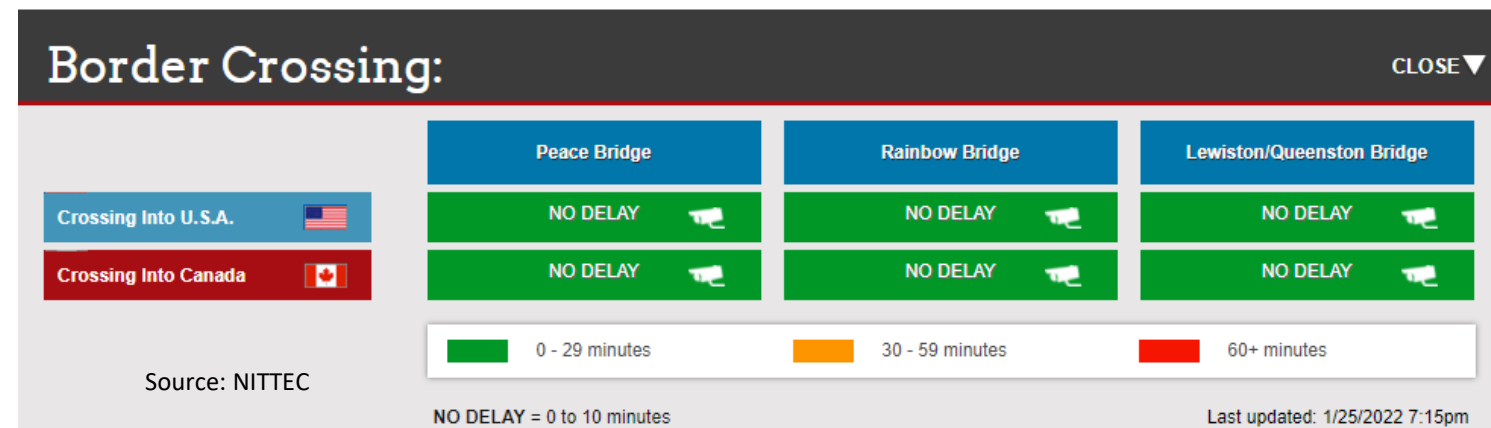

Truck Safety Warning Systems



U.S. Department of Transportation
Federal Highway Administration

- Truck Rollover Warning System
 - WIM determines weight, axle spacing, and vehicle classification to determine safe speed
 - Dynamic warning sign warns truck drivers to slow down
 - *Washington Beltway in Virginia and Maryland* - No accidents reported during the 3-year post deployment test period
- In-Cab Alerts
 - Real-time traffic alert systems warn drivers of congestion ahead through in-cab alerts
 - Gives truck drivers time to reduce speed safely to help prevent crashes
 - *New Jersey DOT Real-Time Traffic Alert System for Commercial Vehicles* - Partnership with Intelligent Imaging Systems (Drivewyze) and INRIX, offering in-cab traffic congestion updates and slowdown alerts



Source: MNDOT

Truck Safety Warning Systems (continued)



U.S. Department of Transportation
Federal Highway Administration

- Dynamic Truck Downhill Speed Warning System
 - WIM sensor information calculates maximum safe descent speeds for trucks
 - Safe speed posted on DMS to alert drivers as they approached
 - *I-70 in Colorado* - 13% decrease in accidents and 24% reduction in use of truck runaway ramps
- Bridge and Tunnel Strike Mitigation
 - Overheight warning systems and early warning detection systems
 - Driver education and guidance systems
 - Vehicle-based technology



Source: CDOT



Georgia High Risk Commercial Vehicle Notification Project Case Study



in partnership
with



High-Risk Commercial Motor Vehicle Notifications

Kaitlyn Stewart, EIT

March 21st, 2022

Interstate Fatalities

Interstate Fatalities - 2019

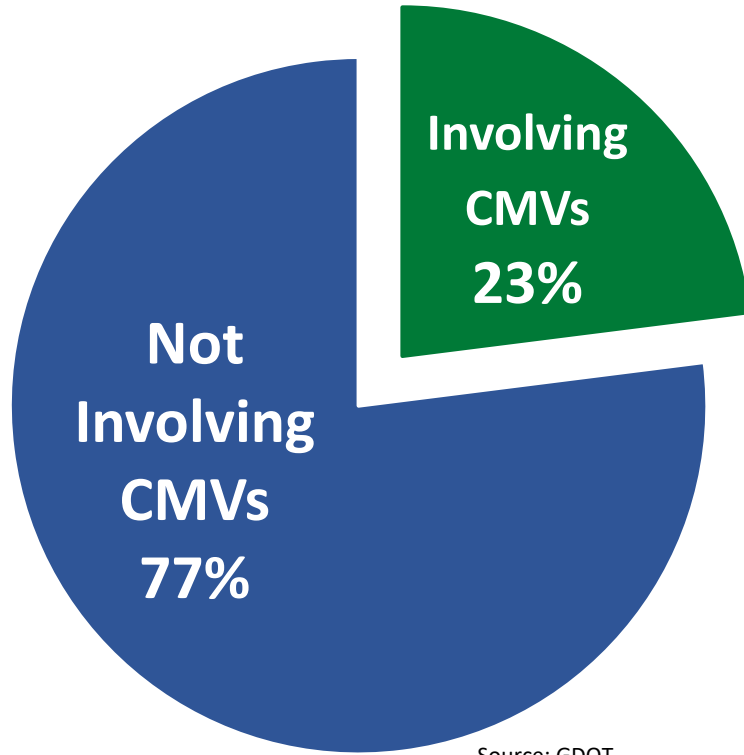

Source: GDOT

CMV's: Commercial Motor Vehicles



Source: GDOT

Challenge

- High value, low cost
- Improve driver experience and driver safety

Why Drivewyze??

Project Goals

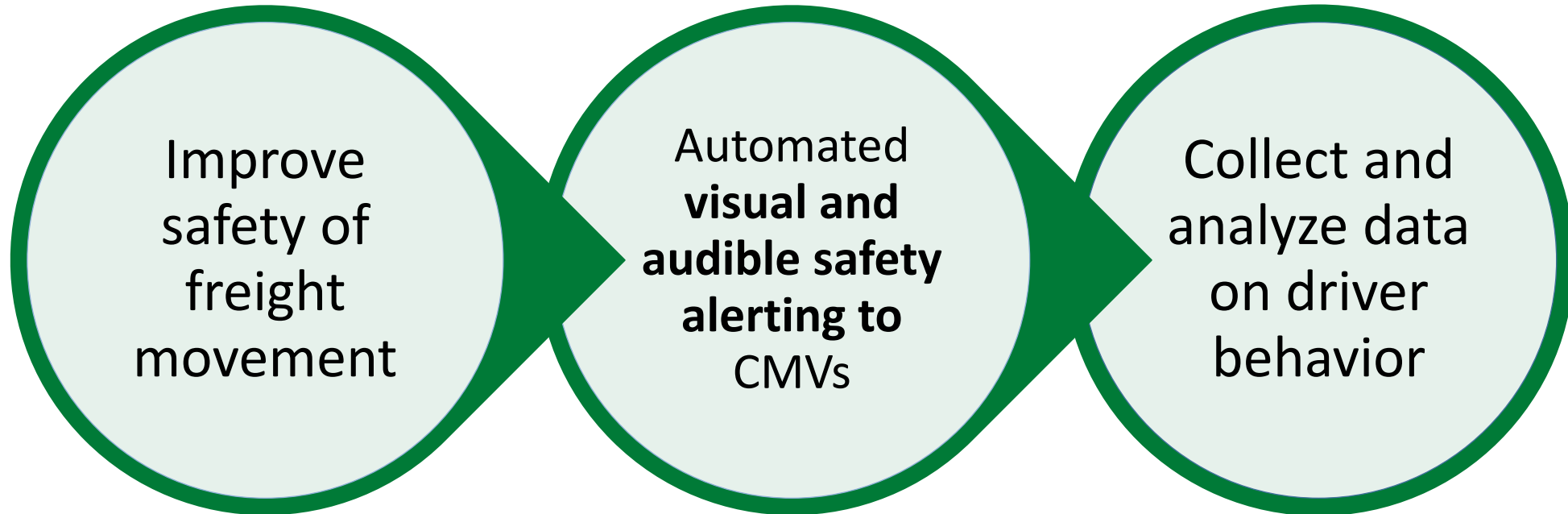

Location Determination

Evaluated high risk areas using crash data:

- Severity
- Crash Type
- Vehicle Type (involving CMV)

Other factors considered:

- Roadway Geometry
- Average Annual Daily Traffic (AADT) and Truck %

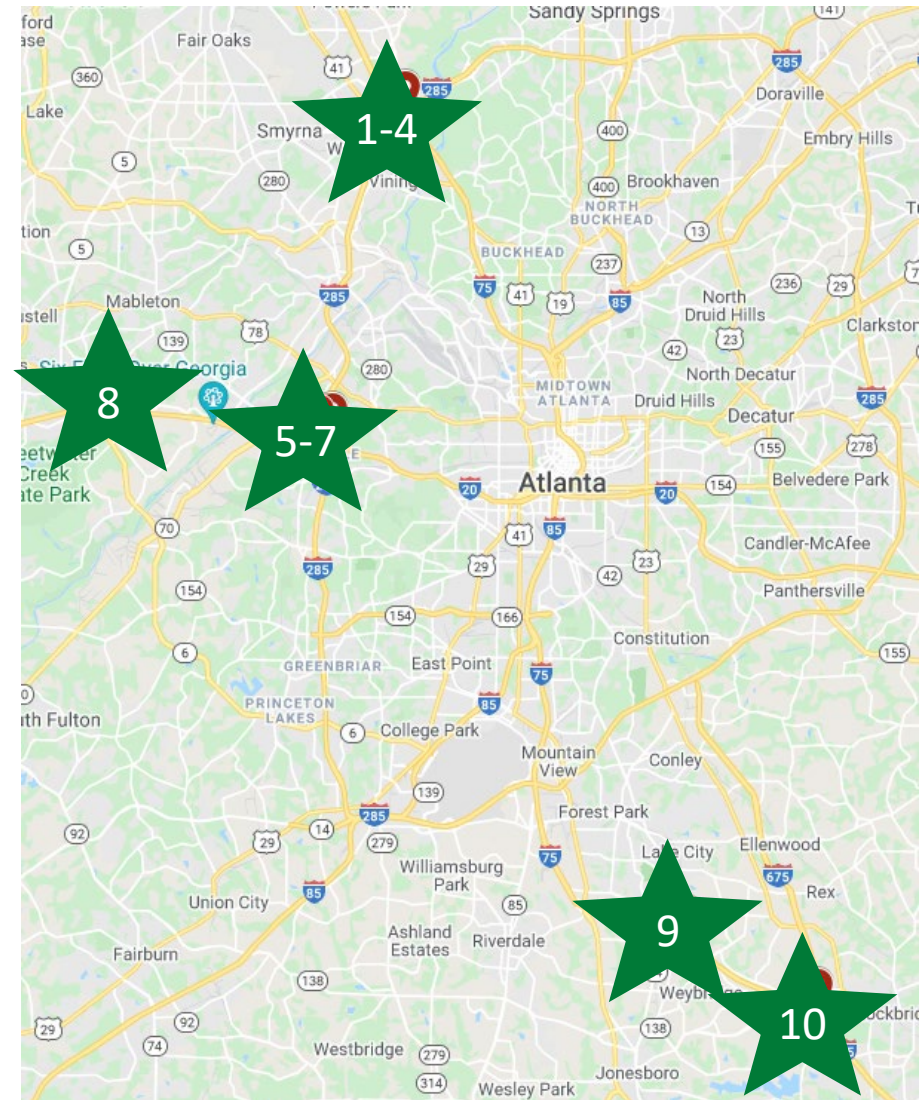

Source: GDOT



Source: GDOT

Messaging

- Crash type – what are we preventing?
- Succinct/not distracting

Locations 1 through 4 – Cobb Cloverleaf I-75 at I-285

1. I-75
SB

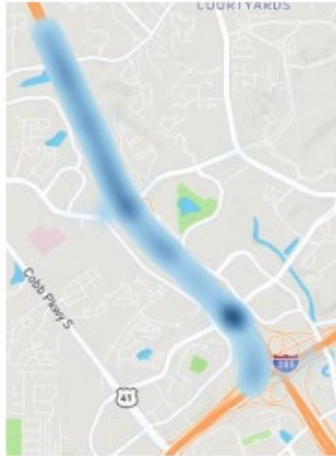

2. I-285
WB

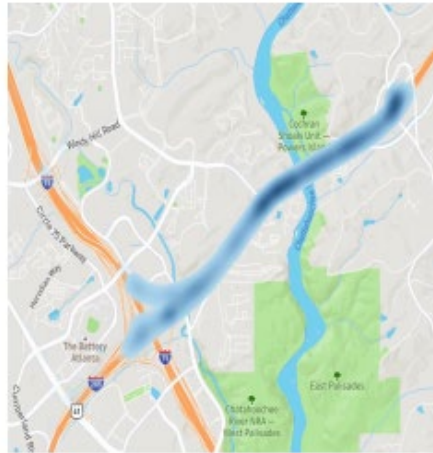

4. I-285
EB

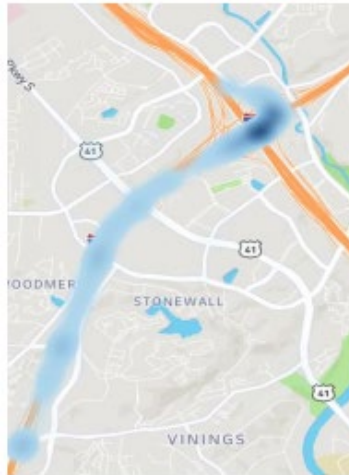

3. I-75
NB

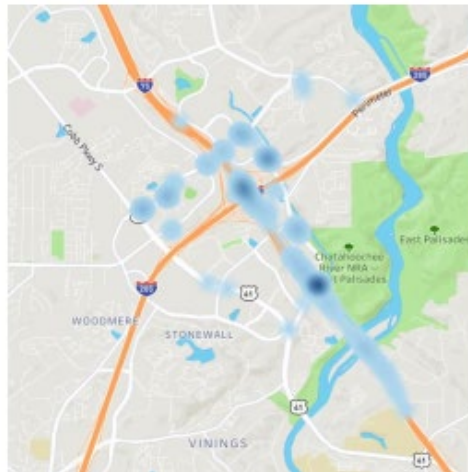

Accident Type:

Sideswipe – Same Direction
Rear-End



Location 10 – I-75 SB at I-675

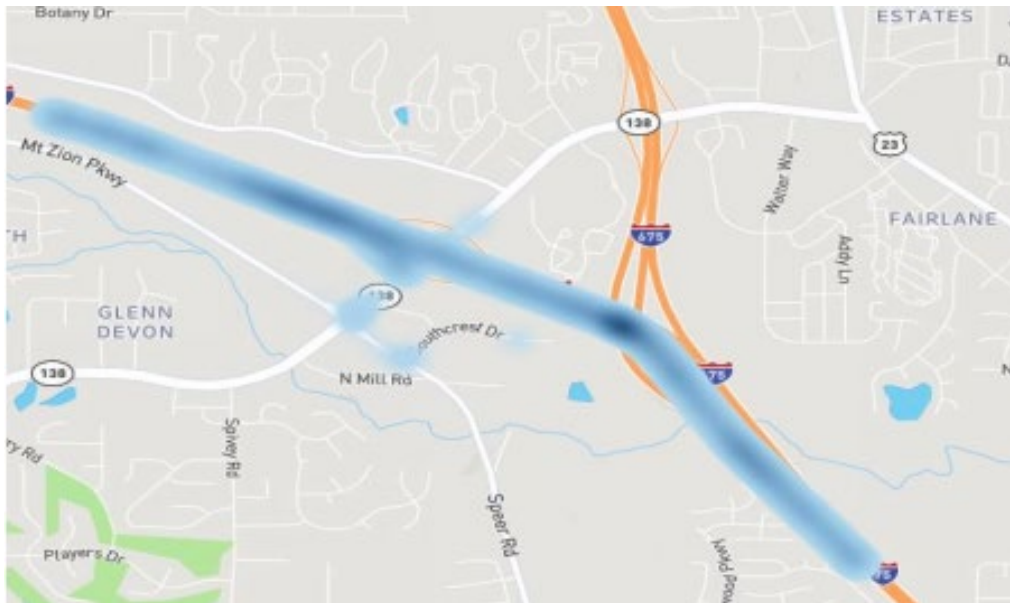

Source: GDOT Density Plot of Hard Braking Events

Accident Type:
Run off the road



Source: GDOT

Results

Location	Approach	% Improvement in Hard Braking
1. I-75/285	SB Approach	+12%
2. I-75/285	WB Approach	+4%
3. I-75/285	NB Approach	+50%
4. I-75/285	EB Approach	+4%
5. I-285/20	SB Approach	-3%
6. I-285/20	EB Approach	+10%
7. I-285/20	NB Approach	+13%
8. I-20	WB at Thornton Rd	-20%
9. I-75	SB at Morrow	+18%
10. I-75	SB at I-675	+19%

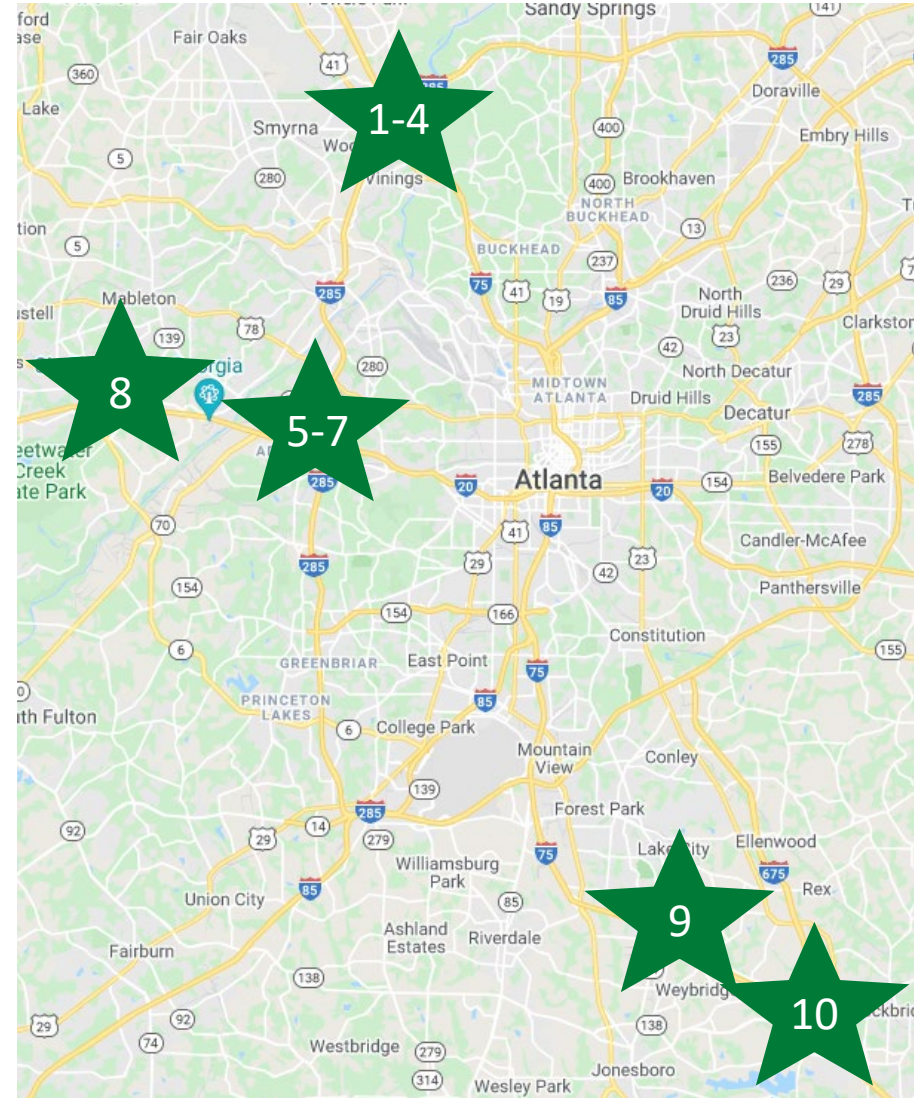

Source: GDOT

Lessons Learned

Currently Addressing:

- What was the reason for negative correlation at two locations?
- Was the reduction in hard braking only when notifications were first displayed?

Potential Next Steps

- Expansion to additional static locations
- Expansion to dynamic messaging

Questions?

Contact Info:

Kaitlyn Stewart, EIT

KaStewart@dot.ga.gov | 404-635-2907

Work Zone Management for Trucks



U.S. Department of Transportation
Federal Highway Administration

- Incorporate truck considerations in work zone transportation management plans and work zone traffic impact analyses
- Include truck driver-focused information and outreach
- Provide real-time traveler information for pre-trip and enroute
- Work Zone Data Exchange (WZDx) used to make harmonized work zone data available for third parties to get information to drivers

STAY ALERT

30%
of fatal crashes
in work zones
involved at least
one large truck

OUR ROADS SAFETY
Partnership for Responsible Driving
www.ShareTheRoadSafely.gov

The graphic features a blue semi-truck on the left and an orange and white traffic cone on the right. The text is in bold, with 'STAY ALERT' at the top, the 30% statistic in the middle, and the 'OUR ROADS SAFETY' logo at the bottom.

Source: USDOT

Work Zone Strategies for Trucks

- Maintain sufficient lane widths to better accommodate large trucks
- Minimize large design speed restrictions for lane shifts, crossovers, or other geometric features
- Encourage truck diversion, ensuring alternate route can accommodate truck volumes, size and weight
- Appropriate design speed
- Sufficient warning of limited lane width
- Adequate acceleration lanes at entrance ramps with good sight distances
- Queue warning systems to advise motors approaching stop vehicles
- Temporary truck-only lane through work zone on heavy freight routes
- Rest area truck parking maintained during road work
- Heavier shadow vehicles with proper truck-mounted attenuators



U.S. Department of Transportation
Federal Highway Administration



Source: Texas A&M Transportation Institute



Texas Connected Freight Corridors Case Study

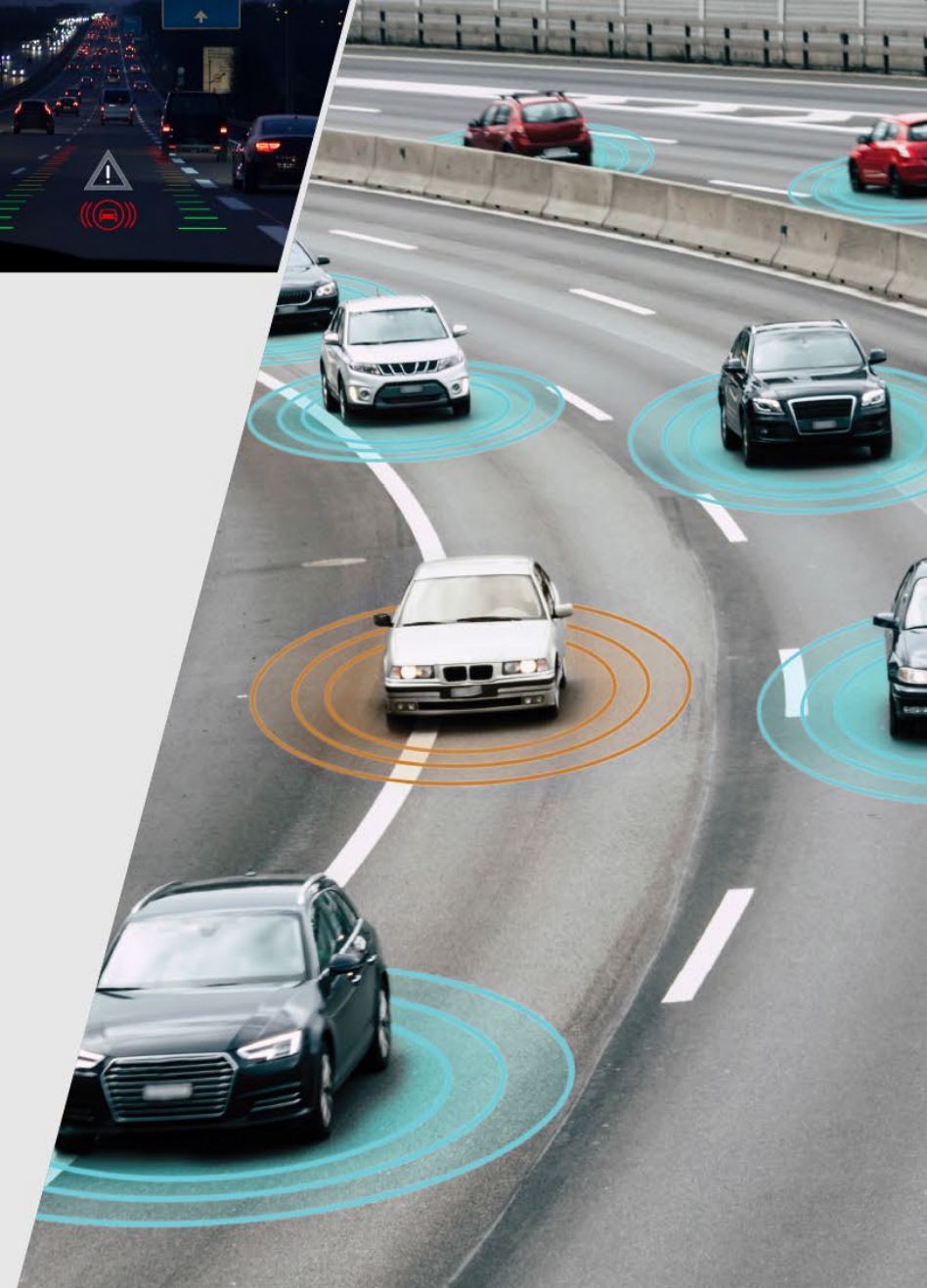

Texas Connected Freight Corridors (TCFC)

Jianming Ma, Ph.D., P.E., PMP®

Traffic Safety Division

Texas Department of Transportation (TXDOT)



Implementing connected vehicle Technology to enable safe and efficient Goods movement through key freight Corridors ion the Texas Triangle.

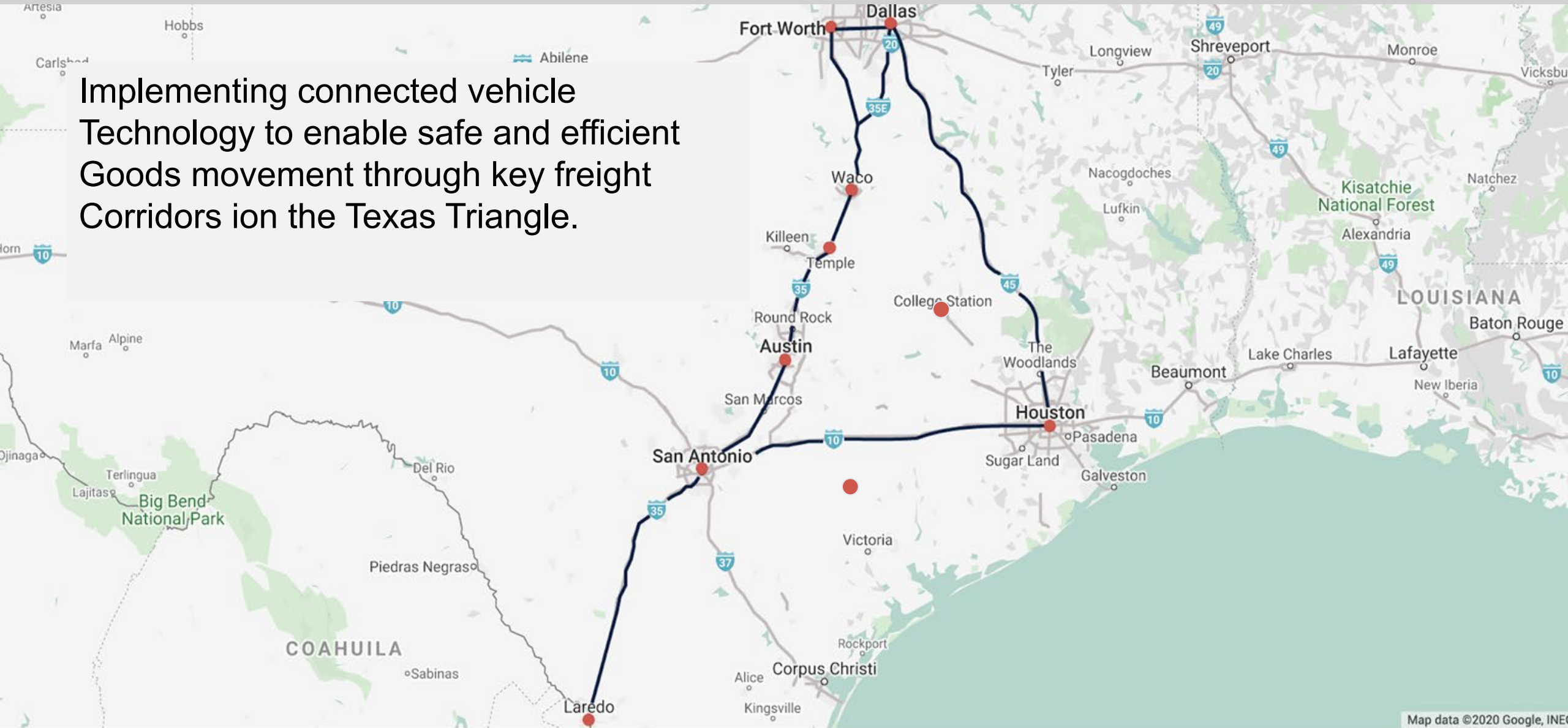



GOALS



IMPROVE SAFETY

OBJECTIVE

- Reduce crashes, injuries and fatalities
- Provide early detection upstream
- Provide advance weather warning
- Improve work zone safety



ENHANCE MOBILITY

OBJECTIVE

- Improve travel time delay
- Increase reliability
- Informed route decisions
- Increase disaster response



REDUCE ENVIRONMENTAL IMPACTS

OBJECTIVE

- Minimize stops, idle time
- Reduce freight congestion
- Improve fuel efficiency



ADVANCED TECHNOLOGIES

OBJECTIVE

- Deploy V2X technologies
- Recruit fleet owners
- Improve data collection



PROMOTE ECONOMIC OPPORTUNITY

OBJECTIVE

- Increase volume, tonnage
- Improve distribution movement
- Position Texas as trade hub



BENEFITS



Gain access to near-real-time information on work zones, traffic queues, alternative travel routes, and wrong-way drivers



Achieve proof of concept before making a large connected vehicle technology investment



Contribute to a model that will set an example for future CV deployment and develop national standards

Overall Project Timeline



Phase 1 Summary

High Level Design and Planning

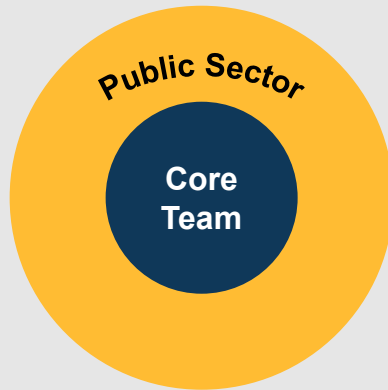

PUBLIC SECTOR

TxDOT Districts

Austin, Bryan, Dallas, Fort Worth, Houston, Laredo, San Antonio, Waco, Yoakum

Regional Agencies

North Central Texas Council of Governments, Houston TranStar, City of Austin, City of San Antonio, Department of Public Safety (DPS)

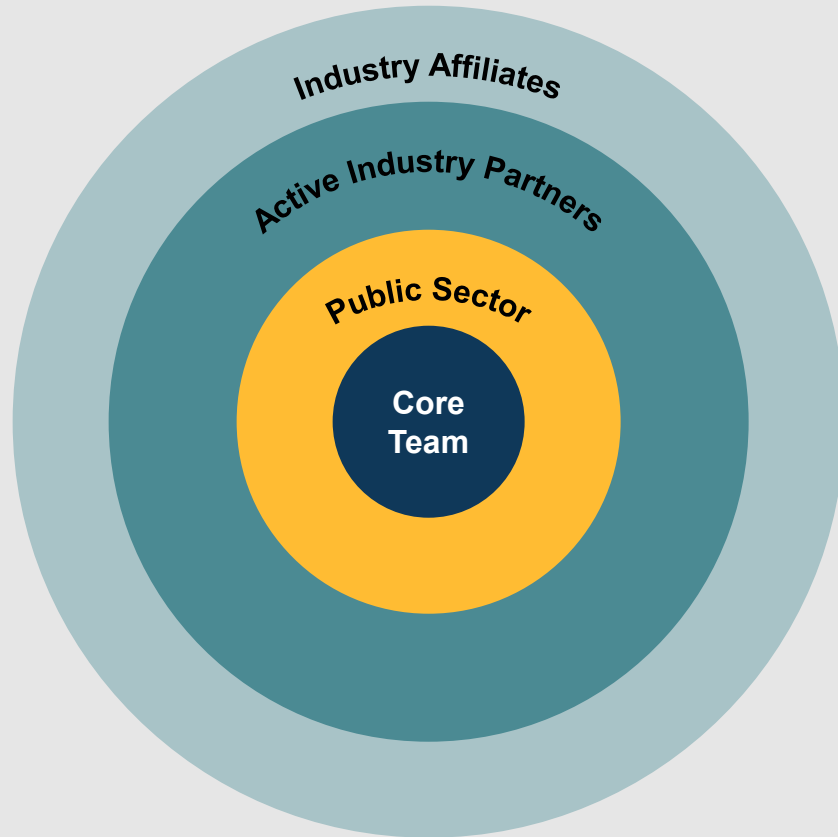

PRIVATE SECTOR

Active Industry Partners

HEB, Crete Carrier, TuSimple, Kodiak Robotics, PepsiCo, Coca-Cola

Industry Affiliates

Fleets: Ford

Telematics: GeoTab, Omnitrac, PeopleNet, Drivewyze

Other: Volvo, Peterbilt, Daimler, Texas Trucking Association, AllianceTexas

Prioritize Connected Vehicle Applications



TIERS

01

Work
Zone
Warning



Queue
Warning



Wrong-
Way
Drivers



Freight
Signal
Priority



02

Advanced
Traveler
Information
System (ATIS)



Road
Weather
Warning



Truck
Parking
Availability



Bridge
Height
Warning



03

Emergency
Electronic
Brake Light



Pedestrian
& Animal
Warning



Eco-
Dynamic
Routing



Border
Wait
Times



= Highlighted applications are prioritized for development



Freight Partners

Industry

HEB

Retail

Coca-Cola

Retail

Persico

Retail

Kodiak

Automated Carrier

Tu simple

Automated Carrier

Crete Carrier Corporation

Automated Carrier

TOTAL PARTNER TRUCKS ESTIMATE:

432-50

OBU EQUIPPED TRUCKS ESTIMATE:

50-100

Identify Candidate Corridors



Down-Selected for Deployment Based on:

- Application alignment
- Partner traffic
- Existing intelligent transportation system (ITS) infrastructure

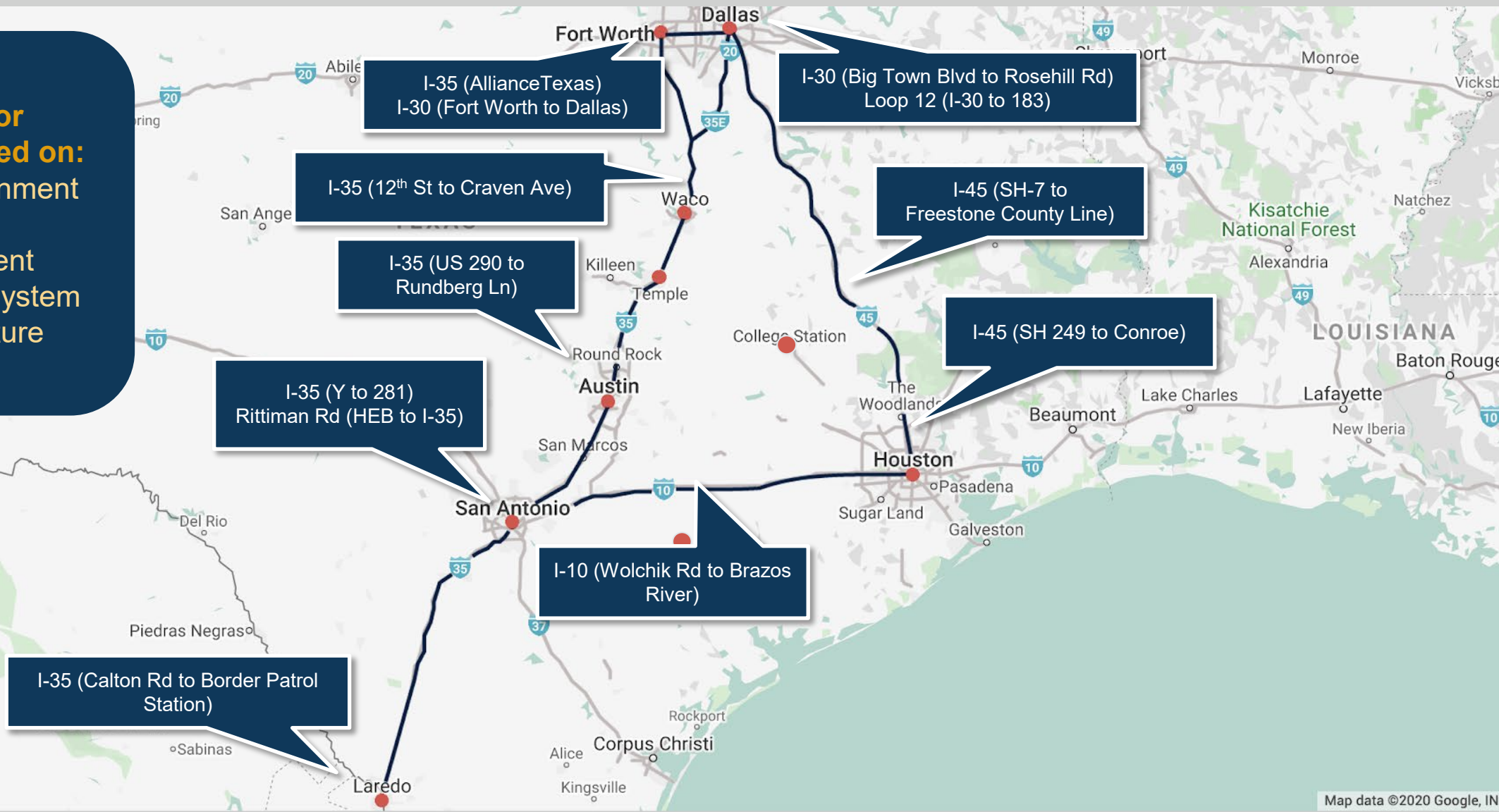

Map data ©2020 Google, INE

Phase 2 Activities

Detailed Design and Testing

Phase 2 Work Flows

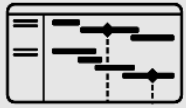

PROJECT MANAGEMENT

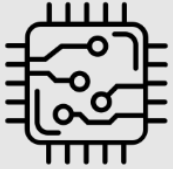
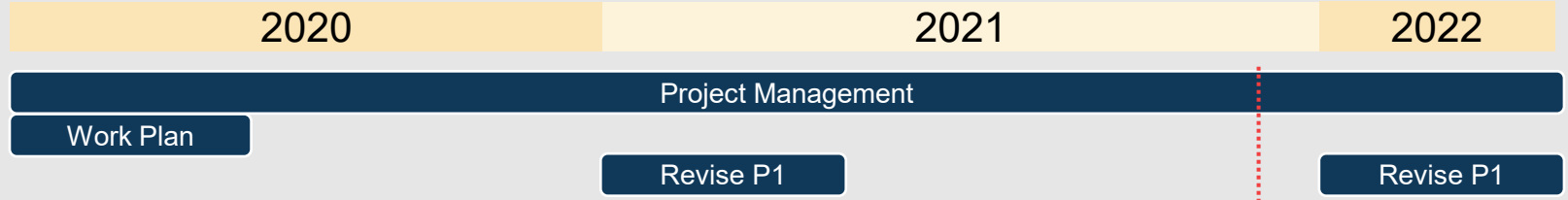

PROCURE HARDWARE

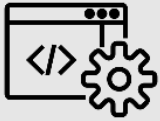

APPLICATION DEVELOPMENT

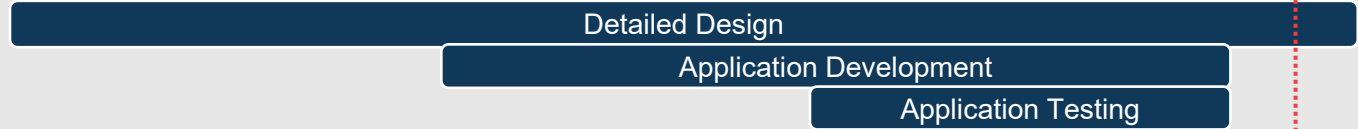

DATA SECURITY MANAGEMENT

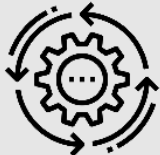

DEPLOYMENT PREPARATIONS



STAKEHOLDER ENGAGEMENT

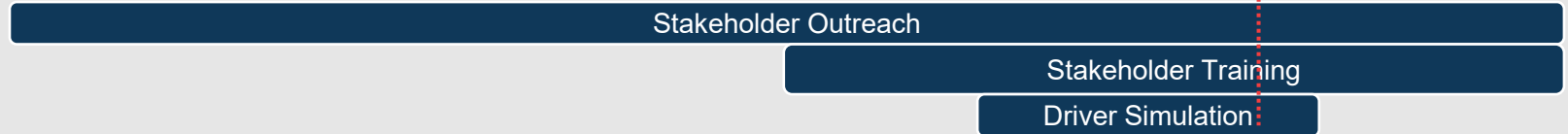

Source: TXDOT

Source: TXDOT

Conduct Detailed Design



Estimated Partner Traffic: 1,235 trips/week

Applications: Queue warning, freight signal priority

Physical Mounting Locations

- Traffic signal poles at signalized intersections
- Power: Y
- Network Connection: 4G modem connected to the City's communication network

More Info: Priority request would be considered ever 3 signal cycles

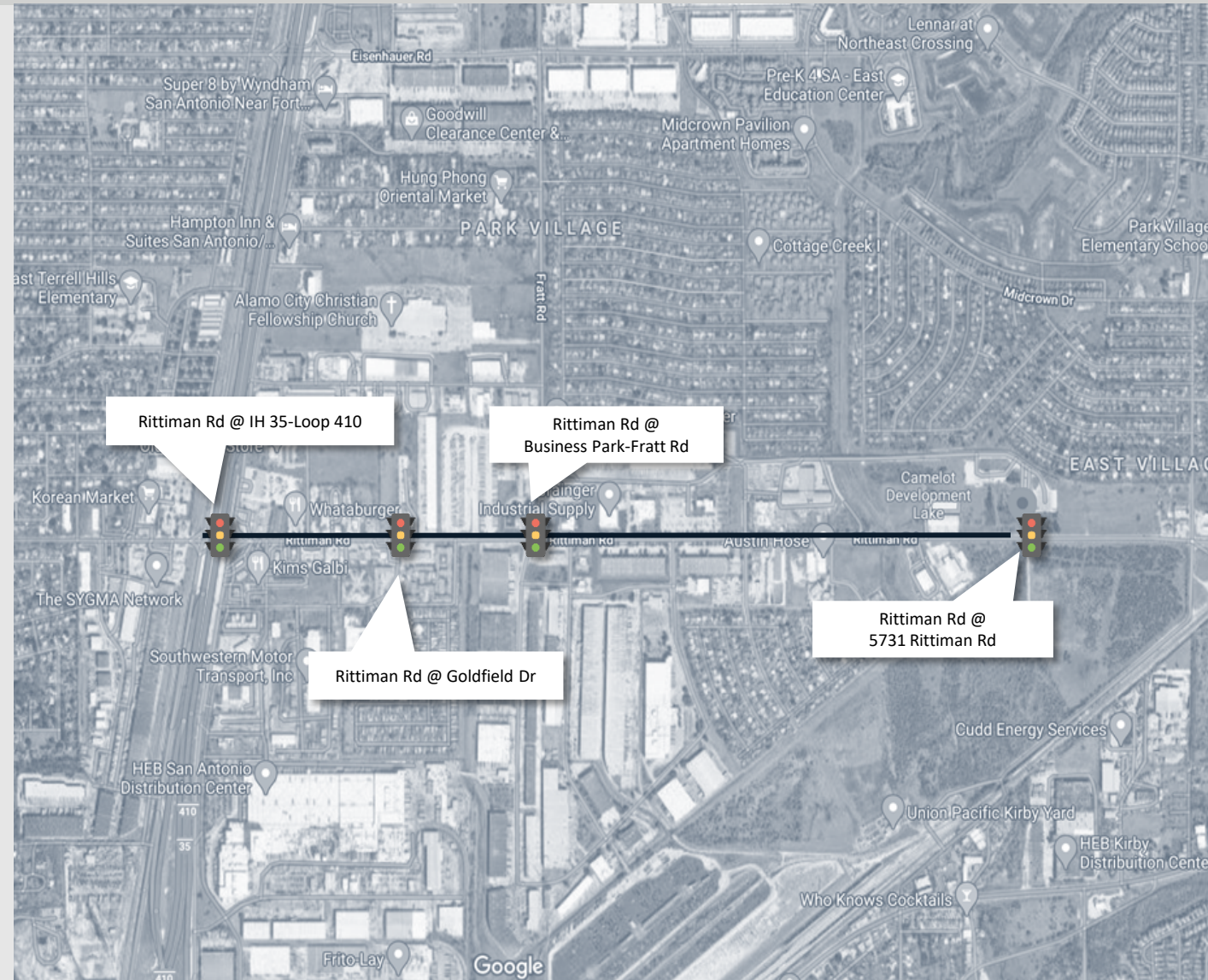



Connected Vehicles (C-V2X) Onboard Units (OBUs)



https://www.danlawinc.com/wp-content/uploads/DS_Through_Glass_V2X_Antenna_V2.pdf

C-V2X and Dual-Mode Roadside Units (RSUs)

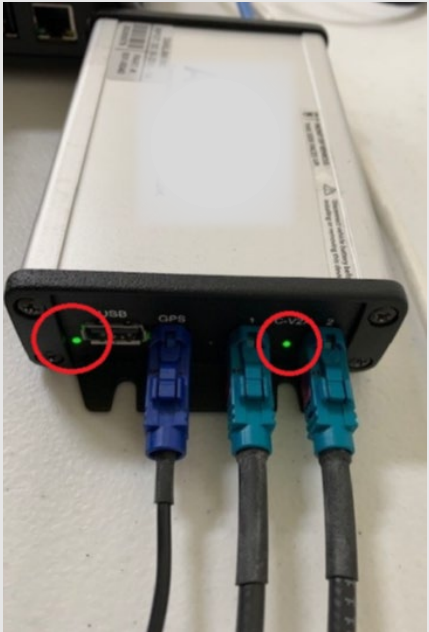

Source: TxDOT



Source: TxDOT



Telematics Providers For Fleet Partners

Omnitracs

Geotab

Peoplenet

Keep Truckin



Integration Solution

Drivewyze

Zero-installation
Participation option



- CVDF: Connected Vehicle Data Framework
 - Integrate CVDF into TCFC system
 - Develop in-house
 - Integrate with Lonestar
- SCMS: Security Credential Management System
 - Results documented in SCMS Integration Report and recommendations presented
 - Multiple viable options identified
 - TxDOT working on procurement document for statewide SCMS services

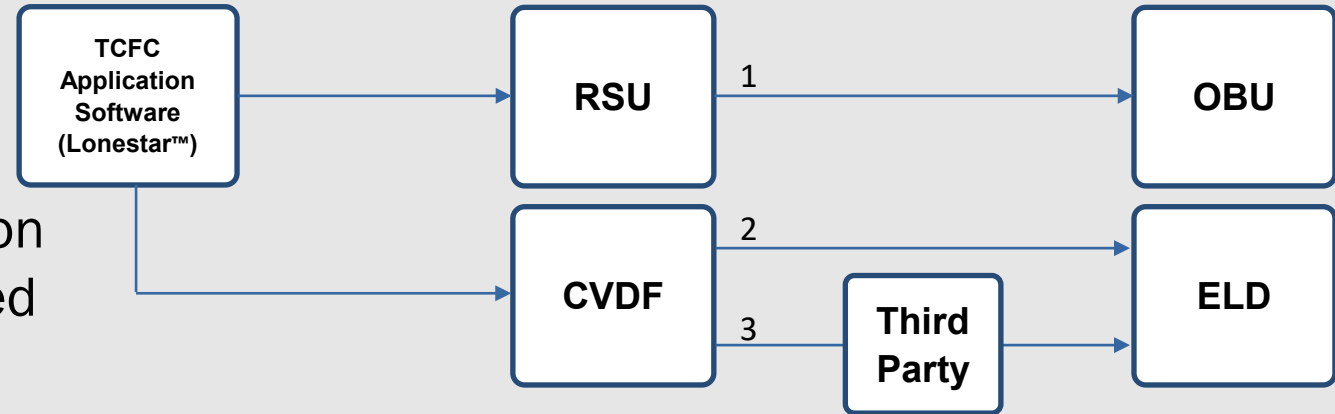

Source: TxDOT

Operation Example – Work Zone Warning

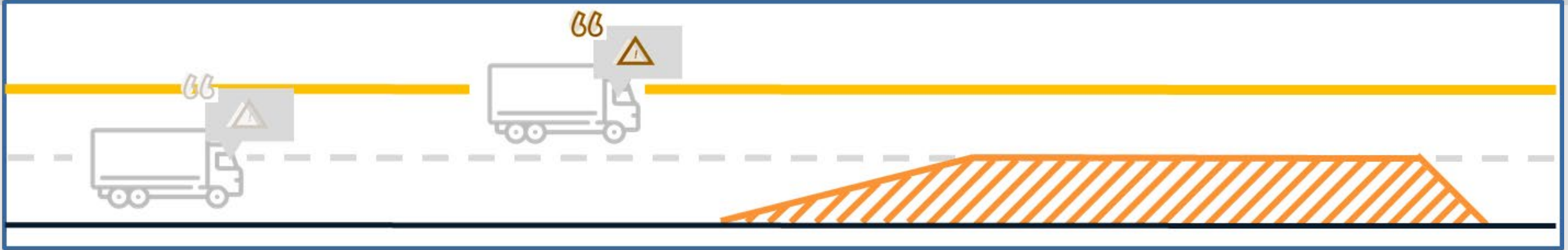

Cab View



TMC Operator

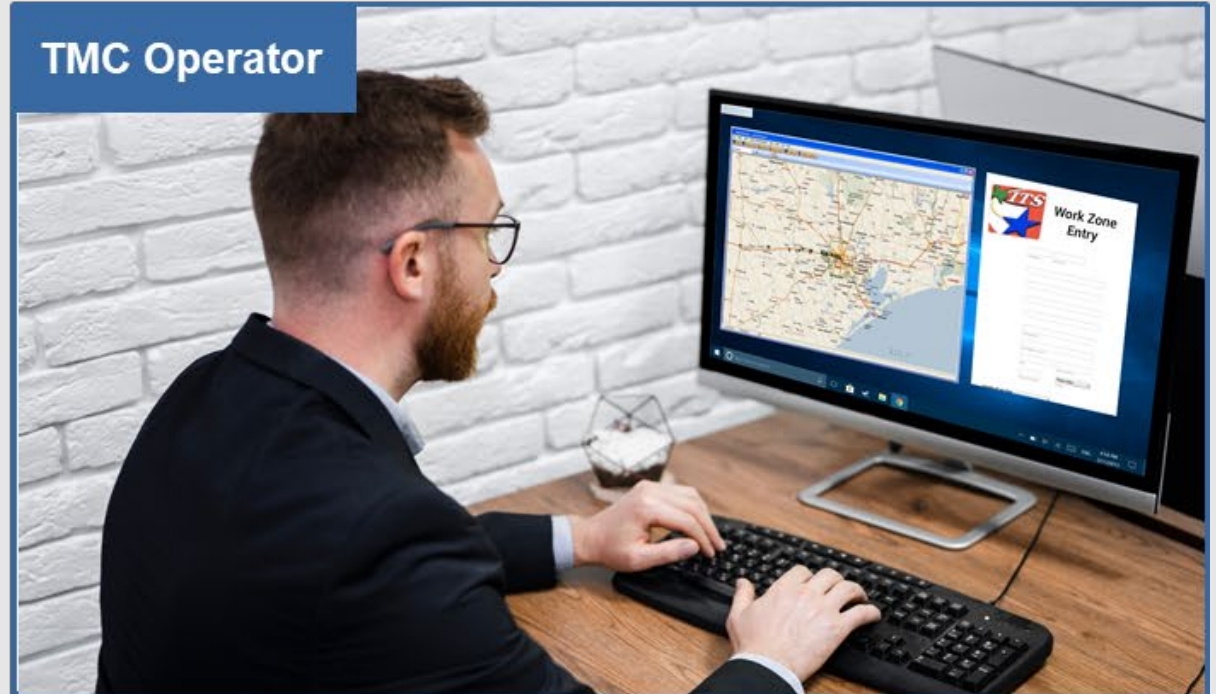

Operation Example – Work Zone Warning

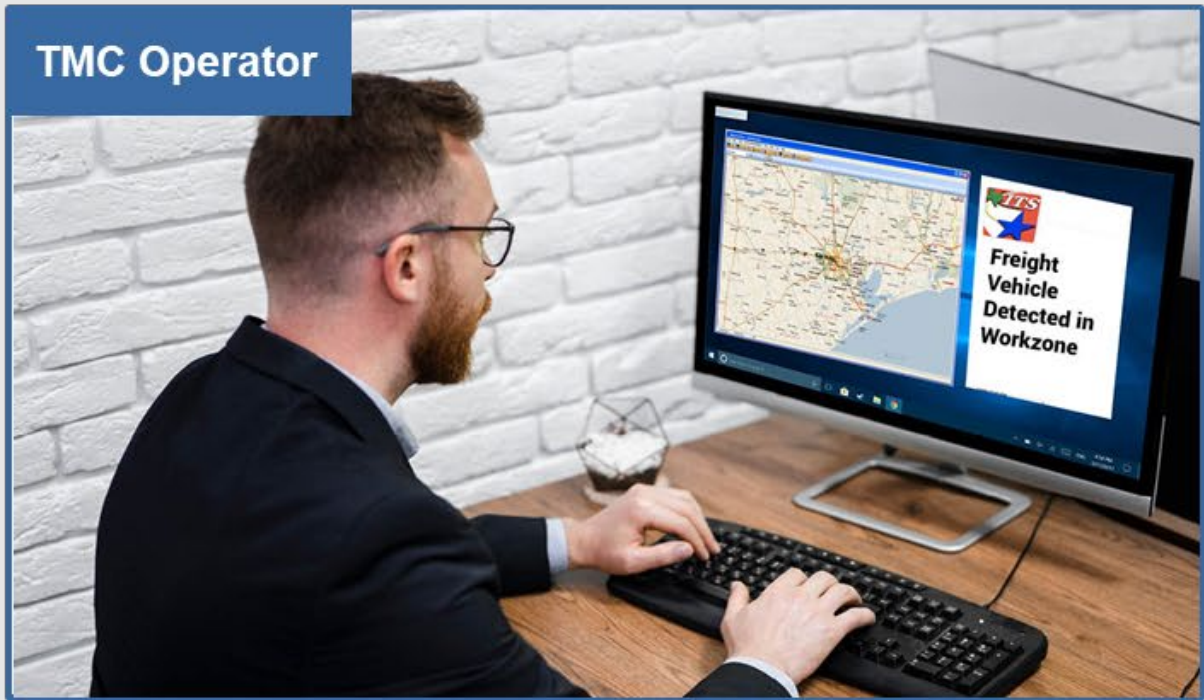



- Continue application development
- Finalize deployment corridors and V2X equipment allocations
- Prepare TxDOT Districts and Freight Partners for deployment
- Phase 3 will be one year of operating and maintaining the new CV system alongside the performance evaluation

Project Contacts



Jianming Ma, Ph.D., P.E., PMP®
Project Manager
512-506-5106
jianming.ma@txdot.gov

Ed Seymour, Ph.D., P.E.
972-994-2207
e-seymour@tti.tamu.edu

Eric Thorn, Ph.D.
210-522-3915
ethorn@swri.org

Kristie Chin, Ph.D.
832-867-3962
kristie.chin@utexas.edu

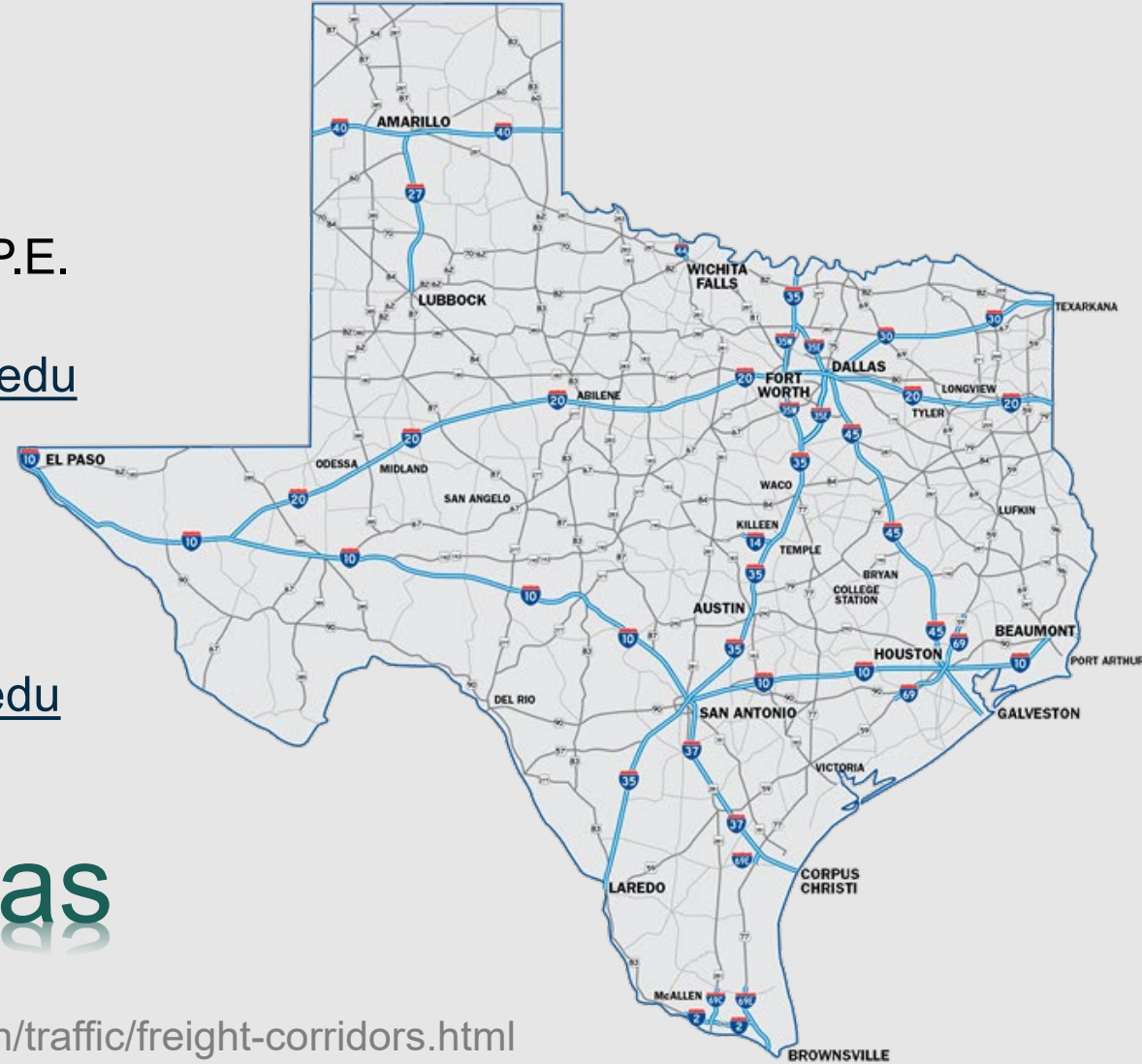

Connecting You With Texas

For more info, please visit <https://www.txdot.gov/inside-txdot/division/traffic/freight-corridors.html>

Connected and Automated Vehicles



U.S. Department of Transportation
Federal Highway Administration

- **Automated vehicles** equipped with technologies that allow a safety-critical control function (e.g., steering, throttle, or braking) to occur without direct driver input
- **Connected vehicles** communicate with others and infrastructure to coordinate movements and increase efficiency and safety
- Automation of supply chain to enhance reliability
 - Cooperative automation applications (vehicle platooning, speed harmonization, and cooperative lane change and merge functions)
 - Vehicle-to-vehicle (V2V), vehicle-to-infrastructure (V2I), and infrastructure-to-vehicle (I2V) connectivity to monitor and report road conditions
 - Trucks interface with automated equipment and facilities at intermodal terminals, distribution centers, shippers, and receivers
 - Automated vehicles technology can be used in automated terminal equipment and autonomous freight delivery



Source: USDOT

Road Weather Management



U.S. Department of Transportation
Federal Highway Administration

Weather Responsive Traffic Management involves road weather data from mobile and connected vehicle technologies to support traffic and maintenance management strategies during inclement weather

- **Advisory strategies** - provide information on prevailing and predicted conditions to both transportation managers and motorists
- **Control strategies** - alter the state of roadway devices to permit or restrict traffic flow and regulate roadway capacity
- **Treatment strategies** - supply resources to roadways to minimize or eliminate weather impacts



Source: FHWA

Road Weather Management (continued)



U.S. Department of Transportation
Federal Highway Administration

Weather responsive traffic management strategies and technologies

- Speed management systems (variable speed limits)
- Low visibility warning systems (snow, rain, dust, fog)
- Forward collision warnings
- High-wind alert systems
- Maintenance Decision Support System (MDSS)
- Transportation operations center
- Traveler information 511 sites
- Emergency truck parking.



Source: FHWA



Wyoming I-80 Connected Vehicle Pilot and Road Weather Management Program Case Study

Why Road Weather Management?

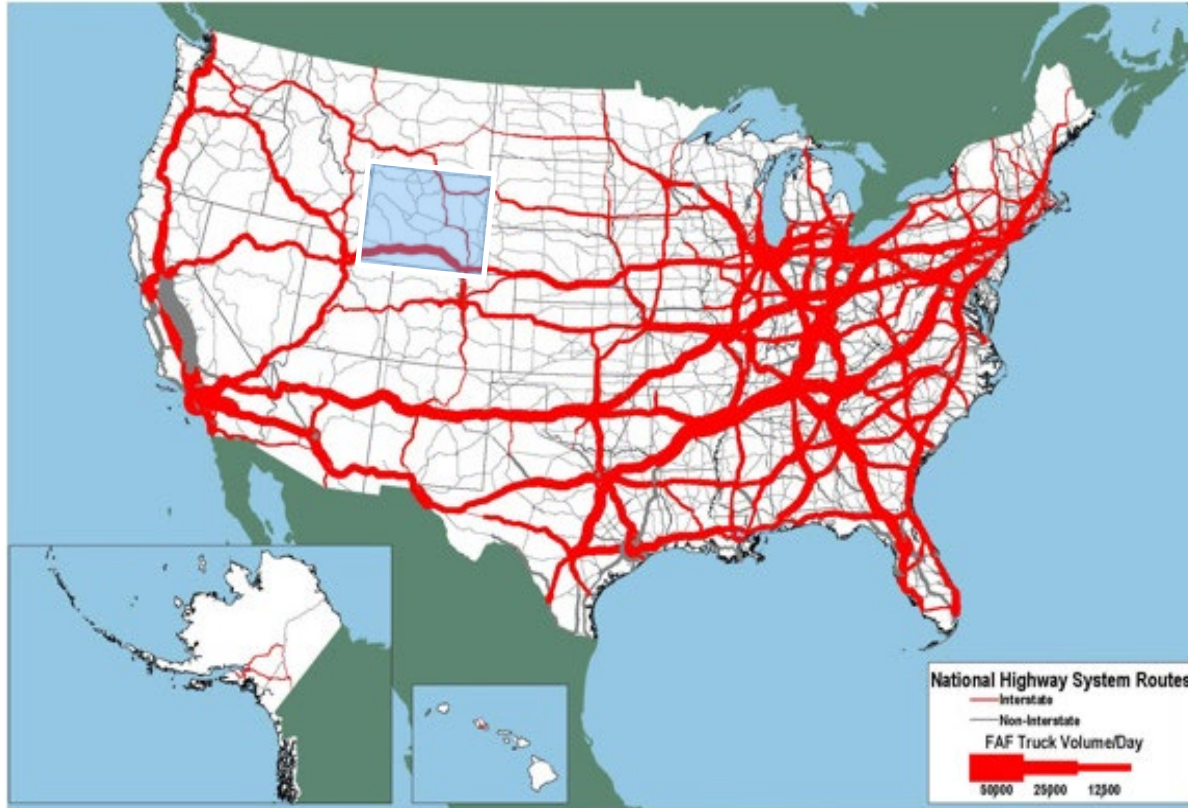

Source: FHWA

U.S. Annual Hours of Blowing Snow
 Estimated from Modeled Data

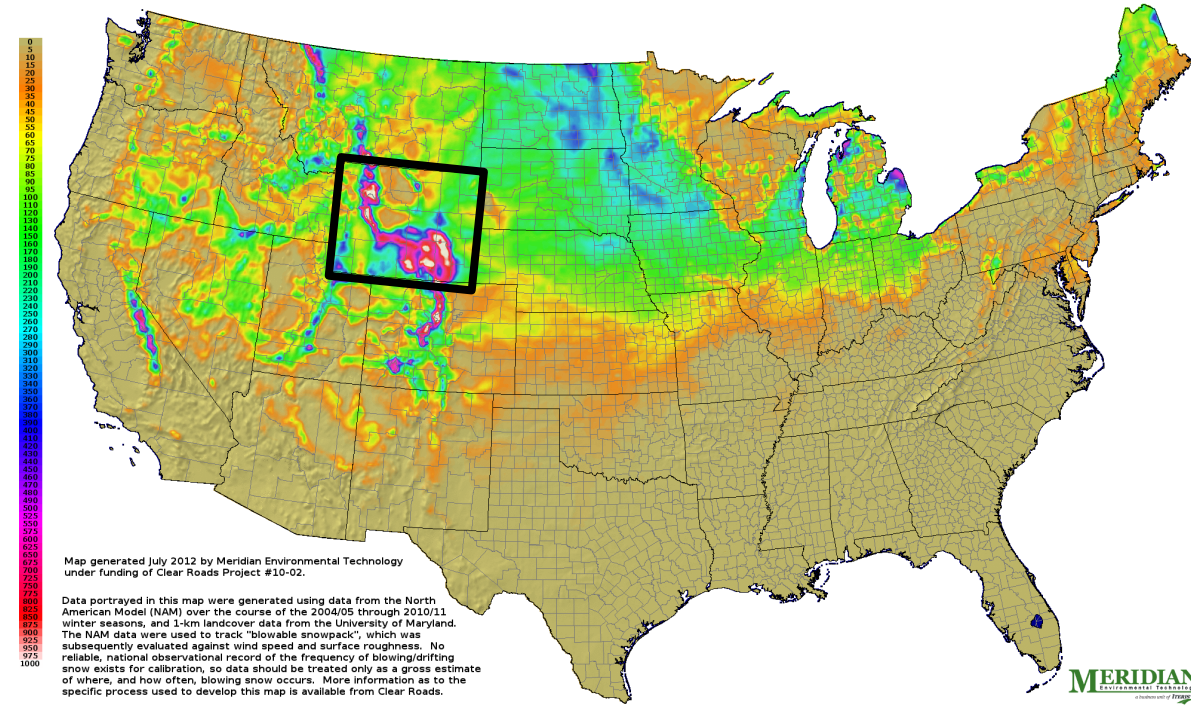

Source: Clear Roads



Wyoming Department of Transportation (WYDOT) Approach



Roadway Design

- Good roadway design
- Select best geometry using modeling tools

Mitigation

- Slope modifications
- Snow fence

Technology

- Intelligent Transportation Systems
- Connected Vehicle Technology

Results of Bad Weather Truck Traffic/Passenger Vehicles



- Societal and Economic impacts
 - Road closures
 - Crashes
 - Fatalities



Source: WYDOT

Road Weather Management Focus



Pre-Trip Systems	Roadside Systems	Maintenance Systems	In-Vehicle Systems
<ul style="list-style-type: none">• Text website• Map website• Phone system• Mobile App• Text/Email	<ul style="list-style-type: none">• Dynamic Message Signs (DMS)• Variable speed limits (VSL)• Highway advisory radio (HAR)	<ul style="list-style-type: none">• Road condition reporting system	<ul style="list-style-type: none">• Connected Vehicle• On-board Systems

Pre-Trip Systems



511 Notify

About 111,000 subscribers
27 mission messages



Website hits

1.6 billion web hits (2019)



511 Phone Calls

About 132,000 calls (2020)



CVOP

About 2400 registered users



Mobile App

Over 300,000 downloads

CVOP: Connected vehicle operations pilot

Roadside Systems - VSLs



Source: WYDOT

Sign



Source: WYDOT

RWIS



Source: WYDOT

- *VSL System*
 - Sign, RWIS, Speed Sensors
- *People*
 - ITS Technicians
 - TMC Operators
 - Patrol
 - Maintenance
- *Processes*
 - Must have good policies

Current VSL Deployments

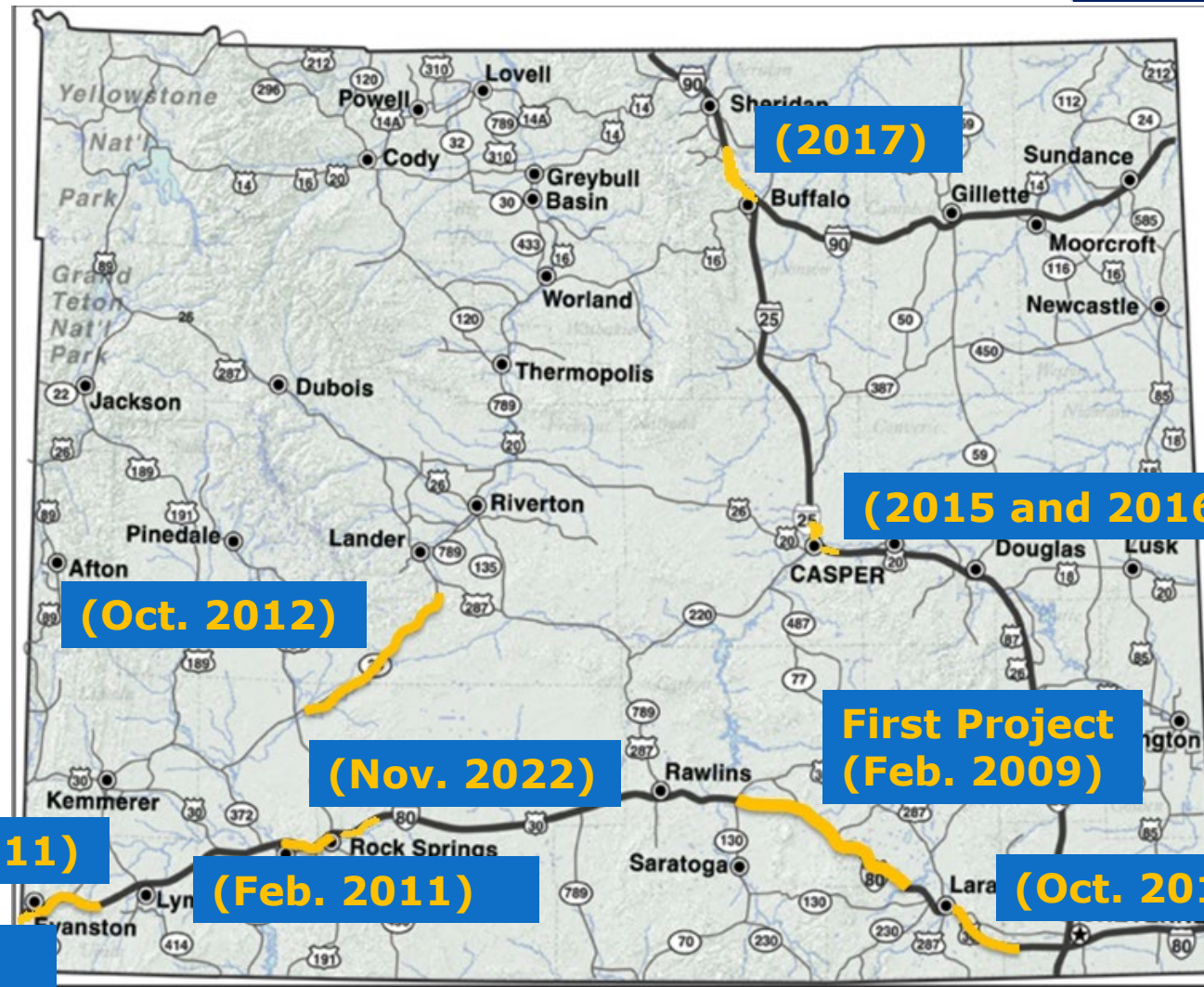

Source: WYDOT

Maintenance Systems - Road Condition Reporting



- *Road Condition Reporting System*

- Tablet-based System For Plow Ops
- Allows condition reports
- Allows crash reports
- Allows geotags for later reporting
- Allows VSL recommendations

A screenshot of a tablet-based road condition reporting interface. The top status bar shows 'I-80 233 00:00', '6 MPH NW Wyo Hill', 'Weather Alert', and 'VSL Active 45 mph'. The main area is a grid of 14 yellow buttons for reporting conditions: 8-1 Dry Road, 8-2 Wet Road, 8-3 Slick, 8-4 Strick Spots, 8-5 Drifted Snow, Black Ice, Freezing Temps, 9-1 Favorable, 9-2 Snowing, 9-3 Raining, 9-4 Strong Winds, 9-5 Fog, 9-6 Blowing Snow, and 9-7 Reduced Visibility. Below the grid are 'Clear' and 'Send Now' buttons, and a list of geotags: I-25 Section 3, I-25 Section 33, I-25 Section 512, I-80 Section 1, and I-80 Section 2. On the right side, there is a vertical menu with 'Reporting', 'Route Info', 'Messages', 'Map', and 'Event Log'. The bottom status bar shows '10', '8 / 9', and 'VSL'.

Source: WYDOT

Maintenance Systems - RCR



- *Provides information to the plow operator*
- Current location to a 1/10 mile
- Weather forecast
- Current weather
- State of DMS
- RWIS information

A screenshot of a plow operator's maintenance system interface. The interface is divided into several sections. At the top left, there is a red warning triangle icon, followed by the text "I-80 233 00:00". To the right of this, there is a search bar and a green play button icon. Further right, there are three status indicators: "6 MPH NW Wyo Hill", "Weather Alert", and "VSL Active 45 mph". Below these indicators, there is a map showing the state of Wyoming and surrounding areas. The map is overlaid with various colored regions: green, yellow, and pink. On the left side of the map, there is a sidebar with several controls: "MAP" and "WEATHER" tabs, "No Alert" status, and a list of map layers: "Base Map", "Wind", "Severe", "Warnings", "Watches", and "Advisories". Each layer has a corresponding icon and a slider. On the right side of the map, there is a vertical menu with five yellow buttons: "Reporting", "Route Info", "Messages", "Map", and "Event Log". At the bottom left of the map, there is a watermark that reads "Licensed for Developer Use Only".

Source: WYDOT

In-Vehicle Systems Connected Vehicle



- Infrastructure to Vehicle
 - Traveler Information Messages
- Vehicle to Infrastructure
 - Driver response
 - Road weather sensor data
- Vehicle to Vehicle
 - Distress Notification
 - Forward Collision Warning



Source: WYDOT

On-Board Applications Distress Notification

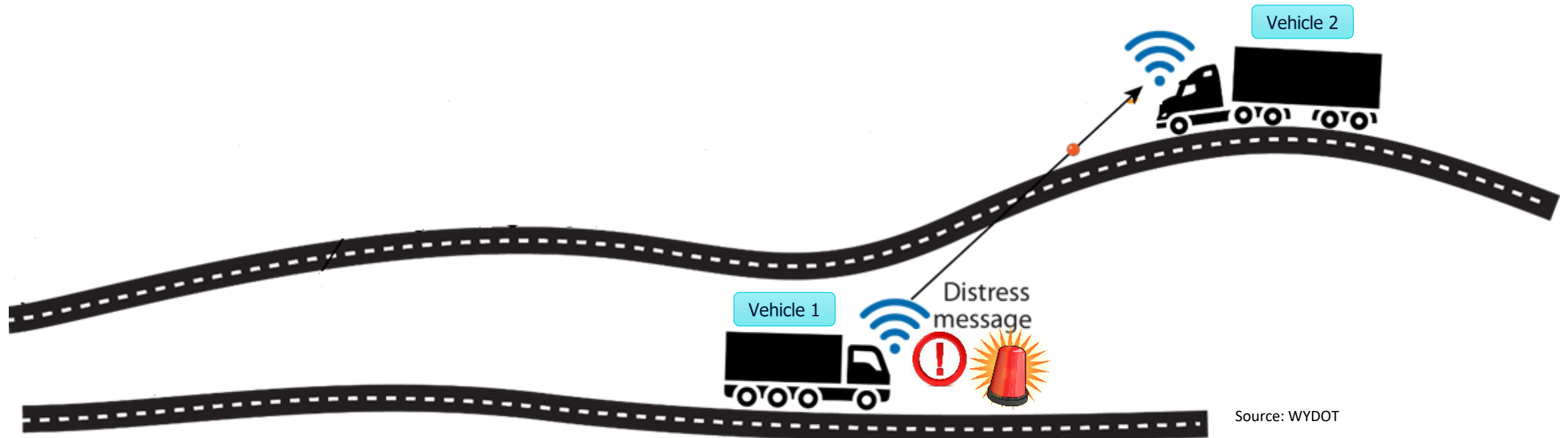

Source: WYDOT

- Generation and broadcast of distress message
- Connected vehicle and road-side unit within vicinity receive and forward message

On-Board Applications Distress Notification

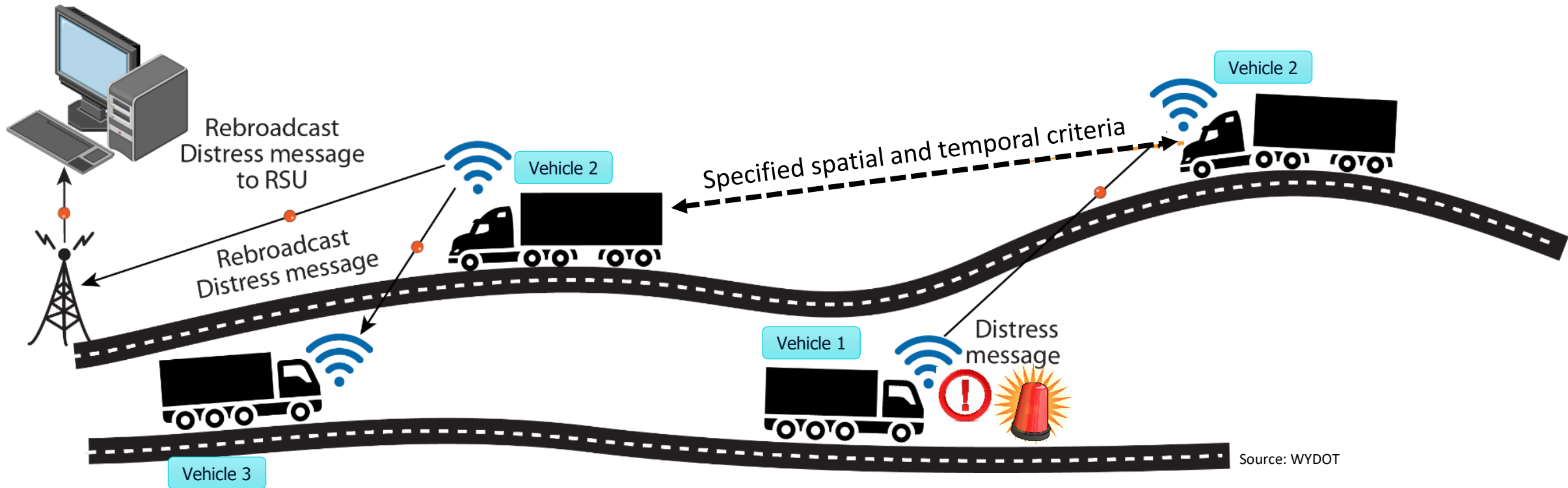

- Connected vehicle and road-side unit within vicinity receive and forward message

Connected Vehicle On-board Systems

- Federal Communications Commission (FCC)
 - Dedicated short range communication (DSRC) is going away
- We lose vehicle to infrastructure and vehicle to vehicle connection applications
- All on-board units were purchased with DSRC and Satellite capability
- Statewide traffic incident messages being delivered by satellite



Source: WYDOT

Arterial Management and Traffic Signal Timing for Trucks



U.S. Department of Transportation
Federal Highway Administration

- Arterial Management Systems - Manage traffic along arterial roadways, employing vehicle detectors, information communication technologies, and traffic signal systems
- Truck Signal Priority
 - Signals at intersections with high truck volumes extend green time to allow trucks to make it through an intersection without stopping
 - Port gates are timed to control flow through the port and into gates, channeling queues and preventing blockages at signalized intersections
- Freight Vehicle Priority - Systems combined with dedicated routing lanes, channeling truck flow and avoiding adverse mixing with non-port traffic
- Eco-Freight Signal Priority - Prioritizes based on real-time traffic and emissions data to reduce emissions

Benefits of Truck Signal Priority

- Reduces delays caused by the longer time it takes trucks to accelerate
- Increased vehicular capacity of intersection through minimizing truck start-up lost time
- Provides safer phase termination for trucks (i.e., decision zone protection)
- Reduces truck red light running and potential crash
- Reduces truck emissions

Access Management at Major Interchanges and Freight Facilities



U.S. Department of Transportation
Federal Highway Administration

- **Access Spacing** - spacing driveways from intersections and interchanges; spacing of signalized intersections
- **Driveway Spacing** – aligning opposing driveways and sharing access and service roads
- **Safe Turning Lanes** – providing dedicated left- and right-turn lanes, roundabouts, and innovative intersections
- **Median Treatments** - limiting left turns and providing directional crossovers
- **Right-of-Way Management** – restricting access and maintaining corridor sight distance
- **Local planning and coordination** - planning and coordination on:
 - Corridor access management plans
 - Site plans, subdivisions, and access permits

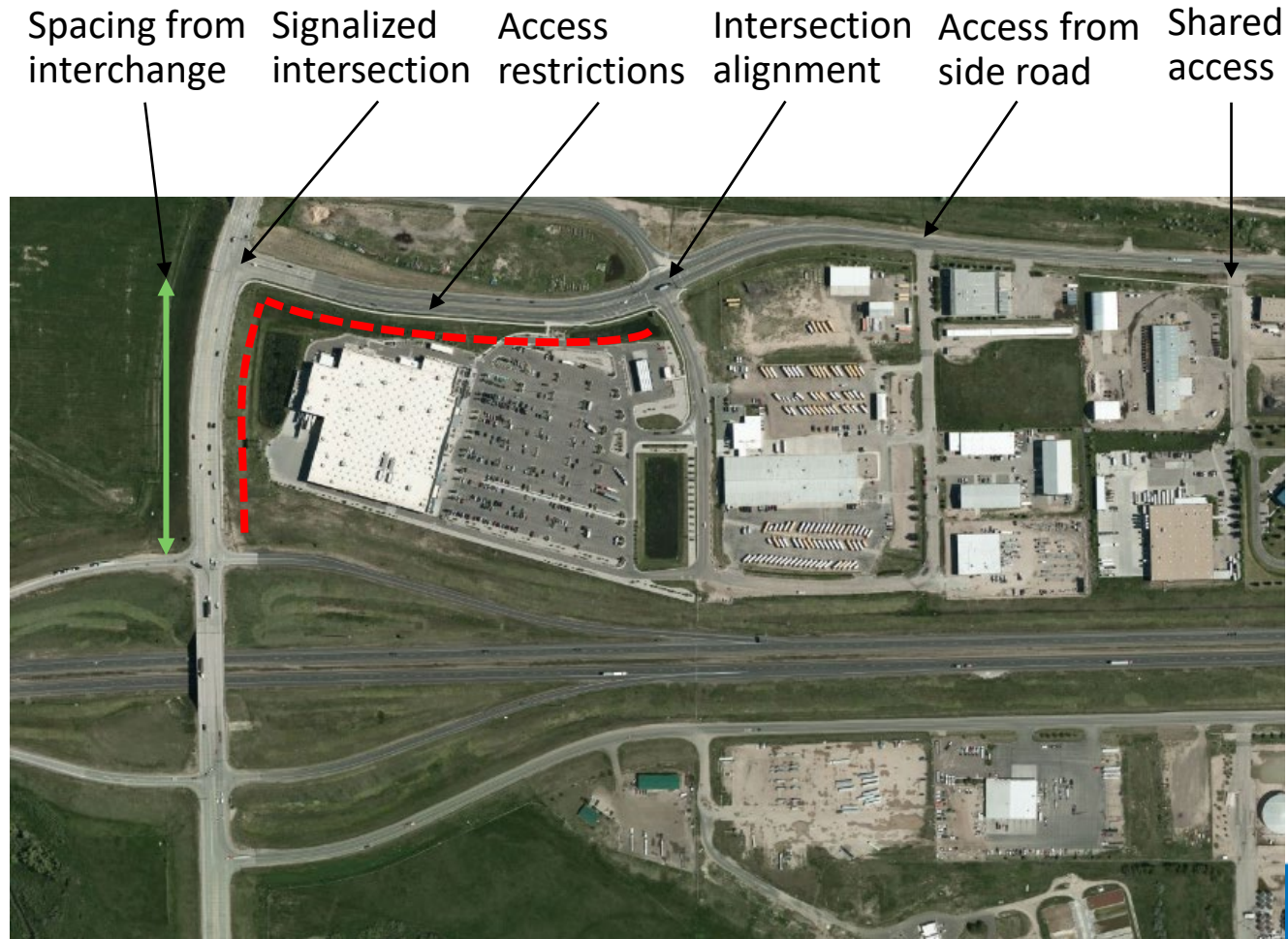

Source: Google Maps

Off-Peak Deliveries

- Off-peak truck delivery programs
 - Shift deliveries from daytime/peak periods to off-hours (overnight)
 - Deliveries can be attended or unattended where drivers leave goods in a safe and secure location
 - May involve incentives to help companies investigate and move to off-peak delivery
- Benefits
 - Increase business efficiency for suppliers and retailers
 - Reduce fuel consumption and CO₂ emissions
 - Reduce traffic during peak hours



U.S. Department of Transportation
Federal Highway Administration



Source: NYC DOT

Off-Peak Deliveries (Continued)



U.S. Department of Transportation
Federal Highway Administration

New York City DOT Off-Hour Delivery (OHD) Program

- 2009-10 Pilot Program Findings
 - 40 to 50 daily delivery tours switched to off-peak hours, for a total carrier savings of \$2.25 million annually
 - 20% of truck traffic could be shifted to off-peak hours, with benefits of \$150-\$200 million in travel time savings and productivity increases
- Current Program Expansion
 - Increase number of deliveries between 7 pm and 6 am at locations with high pedestrian volumes, traffic congestion, and limited curb space
 - Steps to Implementation:
 1. Marketing strategy, website, and focus outreach to businesses
 2. Noise management and noise mitigation best practices
 3. Recognition program to foster behavioral change



Source: NYC DOT

Curb Loading Zone Management

District of Columbia DOT CurbFlow Pilot Project

- Curb parking removed at 9 locations and drivers reserve loading zone time online
- Reduced double-parking by 64%
- Over 6,350 commercial drivers from more than 900 companies registered to use the service and made 15,000 reservations

Columbus, Ohio CurbFlow Pilot Project

- Commercial drivers, taxis, and ride-hailing services use app to make loading zone reservations, as well as check in and check out

Omaha, Nebraska Coord Smart Zone Pilot Project

- Provides drivers for delivery and service providers incentive to load in designated locations where it is safe, efficient, and legal while collecting data for the city



Source: SWBID



U.S. Department of Transportation
Federal Highway Administration

Curbside Management Program

- Map curb space
- Define program objectives and desired uses of curbs
- Inventory potential users, needs, and value propositions
- Develop technology tools (apps) in-house or through partnerships to allocate access, monitor use, collect fees, and enforce rules
- Implement pilot at key locations
- Observe results and adjust / expand program to meet objectives

Active Traffic Demand Management



U.S. Department of Transportation
Federal Highway Administration

- *Active Traffic Management*
 - Dynamic management of recurrent and non-recurrent congestion based on prevailing and predicted traffic conditions
- *Active Demand Management*
 - Dynamic management of demand, including by redistributing travel to less congested times of day or routes, or reducing overall vehicle trips by influencing a mode choice



Source: Pew

Active traffic management strategies and technologies

- Dynamic lane use / shoulder control
- Dynamic speed limits
- Queue warning
- Adaptive ramp metering
- Dynamic rerouting
- Dynamic junction control
- Adaptive signal control

Ramp Metering

- Traffic signals installed on freeway on-ramps to control the frequency at which vehicles enter the flow of traffic on the freeway
- Reduces overall freeway congestion by managing the amount of traffic entering the freeway
- ***Colorado coordinated ramp metering system:***
 - Pilot project in on of I-25 that coordinates ramp meters on the corridor
 - Uses a network of sensors supported by an algorithm to determine how many vehicles to release at each ramp based on traffic flow.



U.S. Department of Transportation
Federal Highway Administration



Source: CO DOT

Integrated Corridor Management (ICM)

- Institutional collaboration and aggressive, proactive integration of existing infrastructure to manage corridors as a whole multimodal system
- Demonstration projects on US 75 in Dallas, TX and I-15 in San Diego, CA
- Consider multimodal freight options (rail, waterway) for major Interstate corridors



Source: DKS Associates



U.S. Department of Transportation
Federal Highway Administration

ICM Response Plan

- Travelers are advised via DMS and other traveler information sources (e.g., 511) to take a parallel route where there is capacity
- Signal timing on the parallel route is changed to manage flow of the detoured traffic

Traffic Incident Management (TIM)



U.S. Department of Transportation
Federal Highway Administration

- Planned and coordinated multi-disciplinary process to detect, respond to, and clear traffic incidents so that traffic flow may be restored as safely and quickly as possible
- Benefits
 - Reduces the duration and impacts of traffic incidents
 - Improves the safety of motorists, crash victims, and emergency responders
 - Reduces the frequency of secondary crashes



Source: FDOT

Florida DOT Rapid Incident Scene Clearance

- Contractors must respond within 60 minutes
- 90 minutes to open travel lanes to traffic
- Bonus if towing company clears travel lanes within 90 minutes
- Requires vendors to have specified extra equipment available 24/7 to respond to commercial vehicle crashes

Managed Lanes and Congestion Pricing



U.S. Department of Transportation
Federal Highway Administration



Source: TxDOT

Managed Lanes

- Highway facilities or a set of lanes where operational strategies are proactively implemented and managed in response to changing conditions



Source: VDOT

Congestion Pricing

- Recognizes differences in trip value by time, place, and users
- Premiums are charged during periods of peak demand to reduce the waste associated with traffic congestion

Truck Lanes



U.S. Department of Transportation
Federal Highway Administration

- **Georgia DOT I-75 Commercial Vehicle Lanes Project (pre-construction)**
 - Two new, barrier-separated, non-tolled commercial vehicle-only lanes
 - Improve mobility and safety for freight operators and passenger vehicles
- **Los Angeles County Metropolitan Transportation Authority/Caltrans I-5 North County Enhancements Project (construction)**
 - Extends existing NB truck-only lane
 - Adds SB truck-only lane to 3-4 miles
- **Florida DOT Truck Lane Restrictions on I-95 and I-75 (operational)**
 - Restricts trucks from the inside travel lane
 - Improves safety by reducing weaving maneuvers and truck conflicts

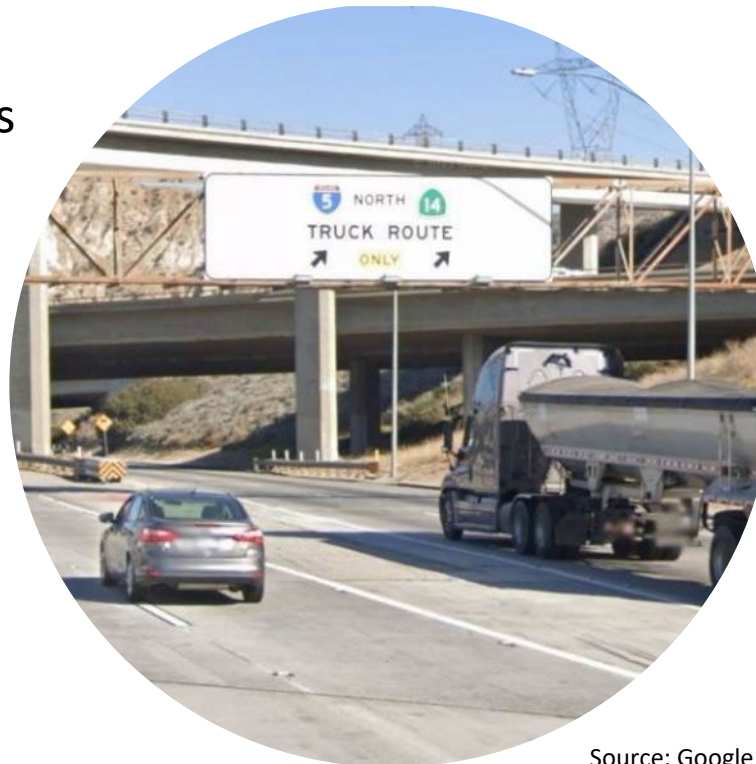

Source: Google

Types of truck lanes

- Separated truck-only lanes
- Separated auto-only and mixed-flow (truck and auto) lanes
- Lane restrictions for trucks
- Interchange by-passes for trucks
- Short connectors from major port facilities

Truck Climbing Lanes



U.S. Department of Transportation
Federal Highway Administration

- Addition of a lane on uphill segments of highways with steep grades
 - Provide additional, safe travel lane for slower-moving trucks
 - Provide additional capacity on uphill grades to allow faster traffic to pass
 - Reduce crashes and backups
- **San Bernardino County Transportation Authority/Caltrans I-10 EB Truck Climbing Lane Project (pre-construction)**
 - Extend existing truck climbing lane along a steep uphill portion of I-10
 - Separate trucks and other slow-moving vehicles from faster-moving passenger vehicles
 - Reduce frequency of truck-related crashes

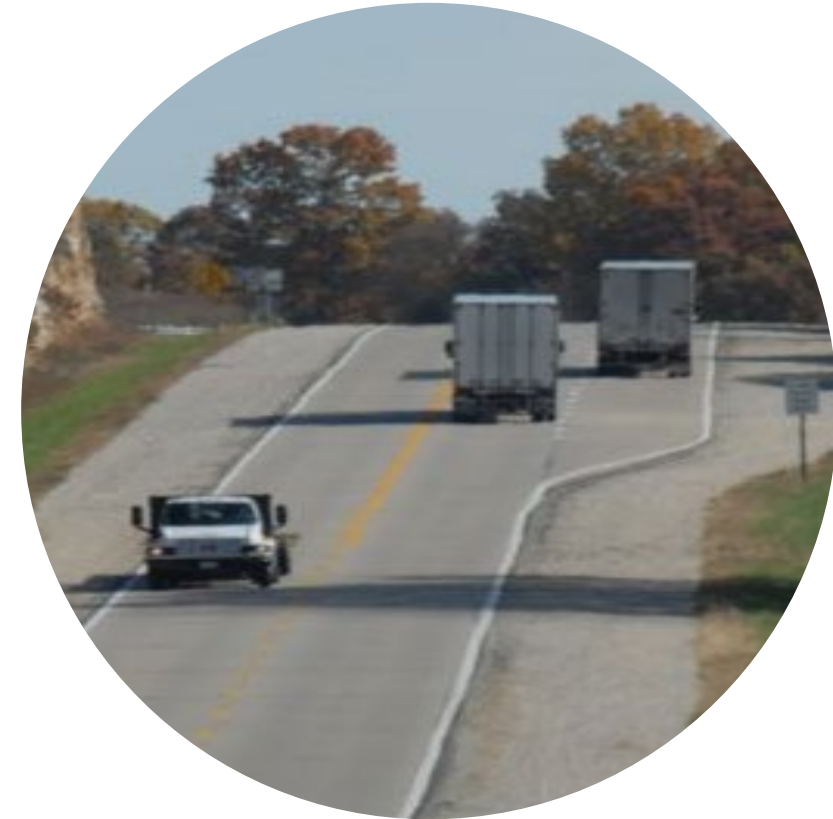

Source: MO DOT

Intermodal Connectors

- Intermodal connectors provide last-mile connection to major rail, port, airport, and intermodal freight facilities
- National Highway System (NHS) Intermodal Connectors inventory, 2017
 - Approximately 1,484 miles of NHS freight intermodal connectors
 - Majority need capacity and state-of-good-repair improvements
 - 54% owned by municipalities
 - 29% owned by State agencies
- Intermodal Connector Improvements
 - Federal formula and discretionary grant programs
 - Specific State funding programs for freight improvement projects
 - Connector improvement projects in Chicago, Seattle-Tacoma, and Stockton leveraged multiple funding sources, including private-sector funding sources



Source: Baltimore Sun



U.S. Department of Transportation
Federal Highway Administration

Improving Intermodal Connectors

- Add auxiliary lanes, driving lanes, turn lanes
- Exit ramp and access upgrades
- Pavement resurfacing and reconstruction
- Grade separation

Marine Highway Program – Marine Highway Routes



U.S. Department of Transportation
Federal Highway Administration

- Marine Highway System currently includes 28 "Marine Highway Routes" that serve as extensions of the surface transportation system
- Marine Highways provide additional freight capacity
 - Relieve landside congestion
 - Reduce wear and tear on roads and bridges
 - Improve economic competitiveness
 - Improve fuel efficiency
 - Reduce emissions
- Areas with land-based congestion are areas that Marine Highway operators could best serve through ocean, inland waterway, and lake access, particularly along the I-5, I-95, and I-10 highway corridors



Source: MARAD

Marine Highway Program – Marine Highway Projects



U.S. Department of Transportation
Federal Highway Administration

Marine Highway Program's goal is to expand the use of navigable waters, working with public and private organizations

- Develop and expand marine highway service options and facilitate further integration into the current U.S. transportation system
- Highlight benefits, increase awareness, and promote waterways as an alternative to "landside" transportation

Developing and expanding ports and terminals requires specialized equipment, infrastructure and vessel needs

- Sufficient channel and berth depth
- Marine structures, such as piers, wharves, and fender systems
- Sufficient cargo storage area, cargo transfer equipment, and terminal handling equipment
- Gate operations
- Landside access improvements, such as rail connections, rail loading/unloading tracks, and roadway improvements

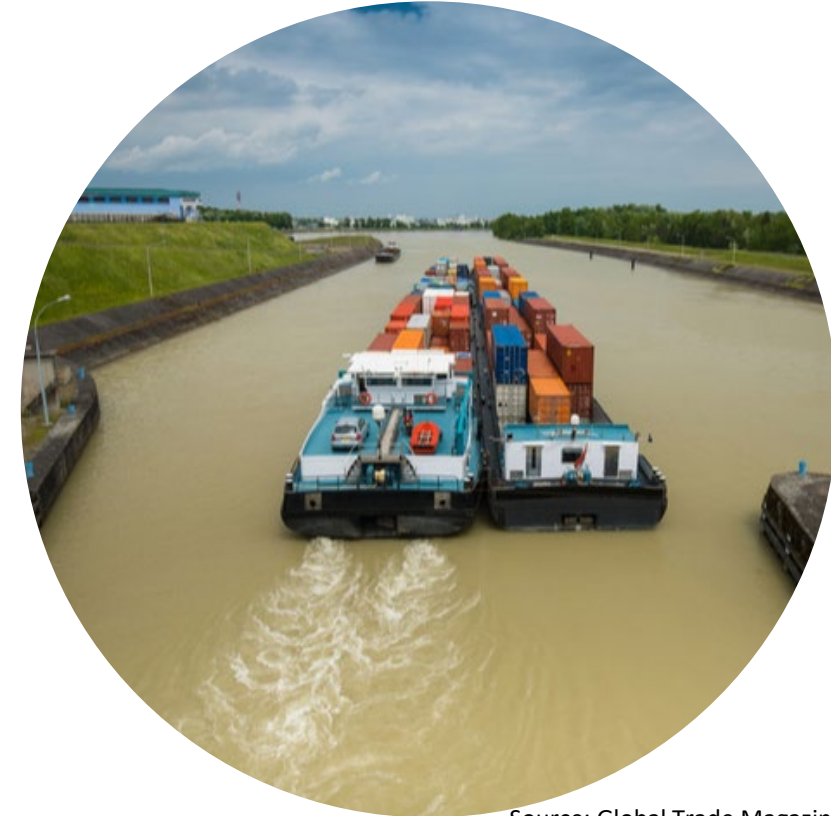

Source: Global Trade Magazine



Iowa Inland Waterways Case Study



Iowa Freight Planning Inland Waterways

FHWA Freight Workshop | March 21, 2022

Contents

- Inventory
- System performance
- Bottleneck identification
- Methods to improve performance, reliability, and bottlenecks
 - State Freight Plan implementation
 - New barge terminal
 - New port statistical area
 - Mooring cell pilot project



INLAND WATERWAYS

Inventory

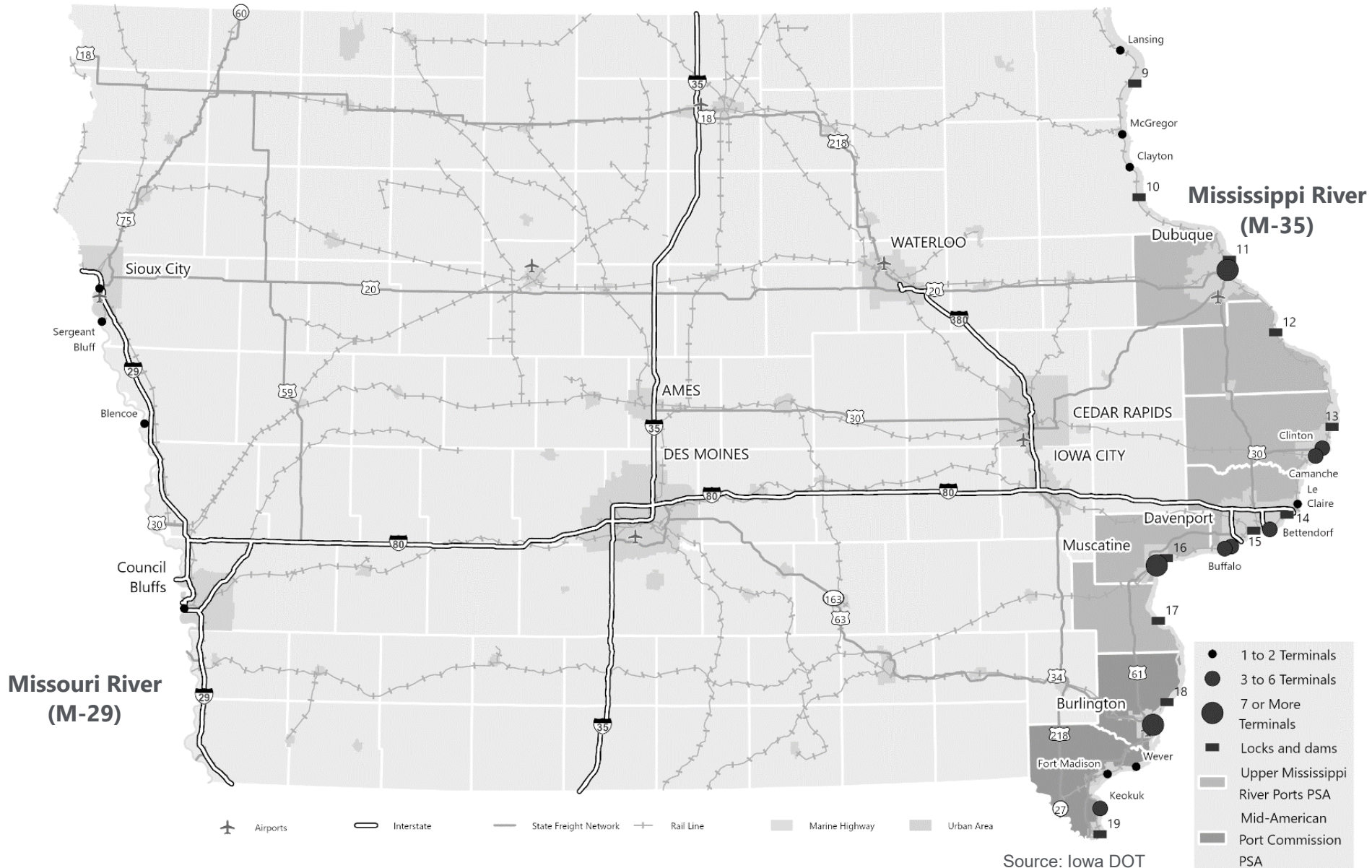

Source: Iowa DOT

System performance

- Condition
- Utilization
- Safety
- Reliability (bottlenecks)

Freight-related safety statistics (M-29 & M-35)

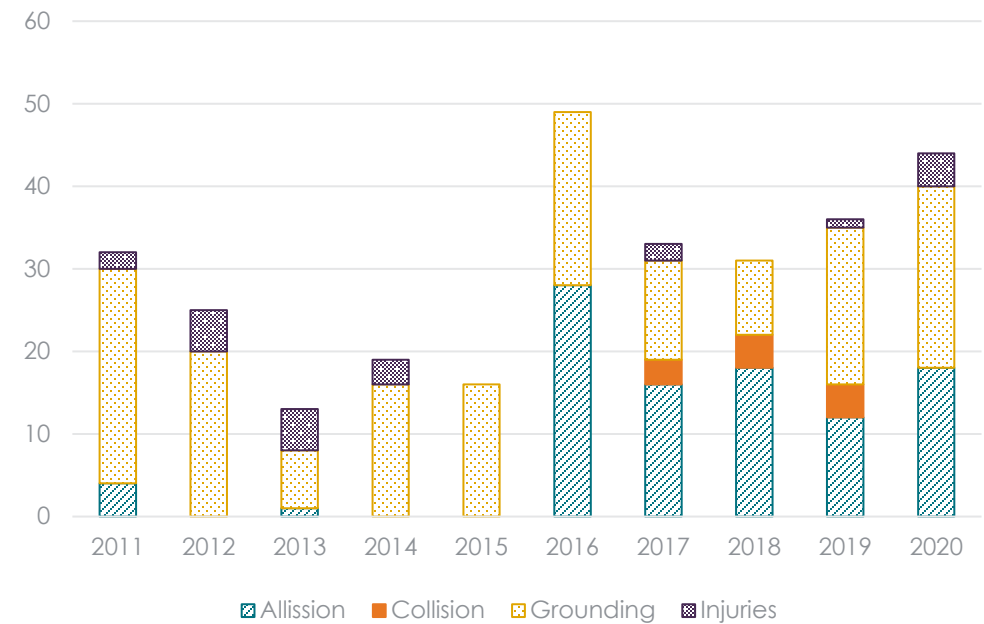

Source: Iowa DOT

Bottleneck identification

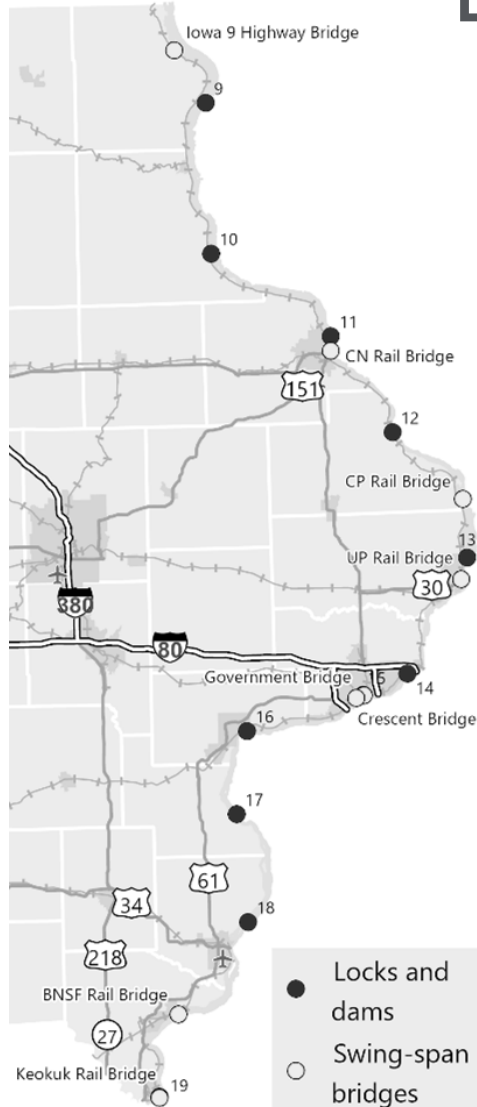

Description	Location	Freight mobility issue
Iowa 9 highway bridge	Lansing	Curve of the river, dolphin protectors, and bridge piers cause barge delays.
Lock and Dam 9	Harpers Ferry	Age (1938), chamber size (600 ft.), delay (1.3 hours), annual closures (9)
Lock and Dam 10	Guttenberg	Age (1936), chamber size (600 ft.), delay (2.5 hours), annual closures (7)
Lock and Dam 11	Dubuque	Age (1937), chamber size (600 ft.), delay (2.5 hours), annual closures (19)
CN rail bridge*	Dubuque	Swing-span rail bridge must be opened to accommodate barge traffic.
Lock and Dam 12	Bellevue	Age (1939), chamber size (600 ft.), delay (2.1 hours), annual closures (3)
CP rail bridge*	Sabula	Swing-span rail bridge must be opened to accommodate barge traffic
Lock and Dam 13	Clinton	Age (1938), chamber size (600 ft.), delay (1 hour), annual closures (11)
UP rail bridge*	Clinton	Swing-span rail bridge must be opened to accommodate barge traffic.
Lock and Dam 14	Le Claire	Age (1922), chamber size (600 ft.), delay (1.7 hours), annual closures (15)
Government Bridge*	Davenport	Swing-span rail bridge must be opened to accommodate barge traffic.
Lock and Dam 15	Rock Island (IL)	Age (1934), chamber size (600 ft.), delay (2 hours), annual closures (29)
Crescent Bridge*	Davenport	Swing-span rail bridge must be opened to accommodate barge traffic.
Lock and Dam 16	Muscatine	Age (1937), chamber size (600 ft.), delay (2.6 hours), annual closures (11)
Lock and Dam 17	New Boston (IL)	Age (1939), chamber size (600 ft.), delay (1.8 hours), annual closures (17)
Lock and Dam 18	Gladstone (IL)	Age (1937), chamber size (600 ft.), delay (1.3 hours), annual closures (8)
BNSF rail bridge*	Fort Madison	Swing-span rail bridge must be opened to accommodate barge traffic.
Lock and Dam 19	Keokuk	Age (1957), delay (1.4 hours), annual closures (17)
KJRY rail bridge*	Keokuk	Swing-span rail bridge must be opened to accommodate barge traffic.

Methods to improve

State Freight Plan

- Implementation strategies
- Improvements and investments
 - **Missouri River (M-29):** Omaha District priority (Bank Stabilization and Navigation)
 - **Mississippi River (M-35):** St. Paul and Rock Island Districts priority projects

Priority inland waterway strategies according to the Iowa Freight Advisory Council

- #1 Sustainable funding sources
- #4 21st century Farm-to-Market System
- #7 System resiliency
- #9 New intermodal facilities
- #10 Address mobility issues
- #12 Improvement of the inland waterway system
- #13 Availability and use of freight shipping containers
- #15 Impacts of freight on environment and communities

Deferred/backlog maintenance and major rehabilitation and repair costs for Iowa locks and dams

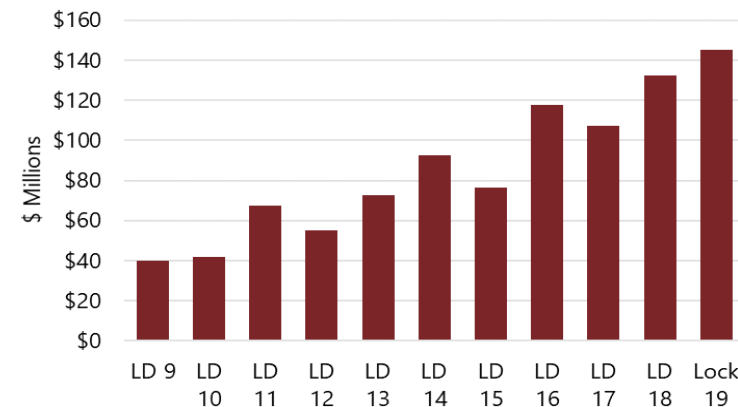

Source: Iowa DOT

Methods to improve (continued 1)

New barge terminal

- Key Cooperative Port of Blencoe
- Location: Missouri River between Sioux City and Omaha
- Construction: Oct. 2020, Grand Opening: June 2021
- Commodities: Corn, soybeans, fertilizers, rock, others



In 2021, the port received 35 loaded barges upstream and shipped 28 loaded barges downstream.



Methods to improve (continued 2)

New port statistical area

- Upper Mississippi River Ports
- Approved in 2020
- Includes existing terminals in eastern Iowa and western Illinois
- Part of “Corn Belt Ports”

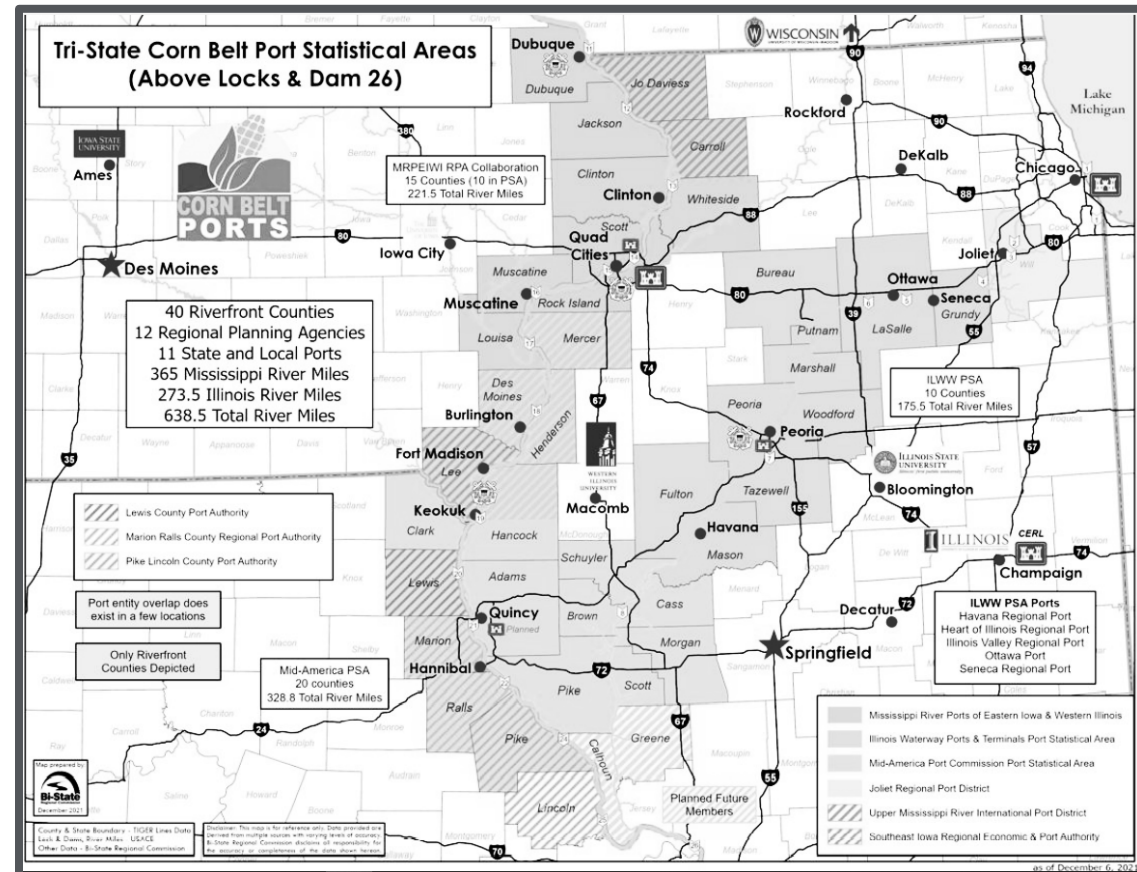

Methods to improve (continued 3)

Mooring cell pilot project

- Mooring cell construction at Lock 14 (LeClaire, IA)
- Possible contributed funds agreement between Iowa DOT and U.S. Army Corps of Engineers
- Benefits
 - Improved lock approach times
 - Reduced environmental impacts
 - Improved operational safety
 - Replicability (other State DOTs)

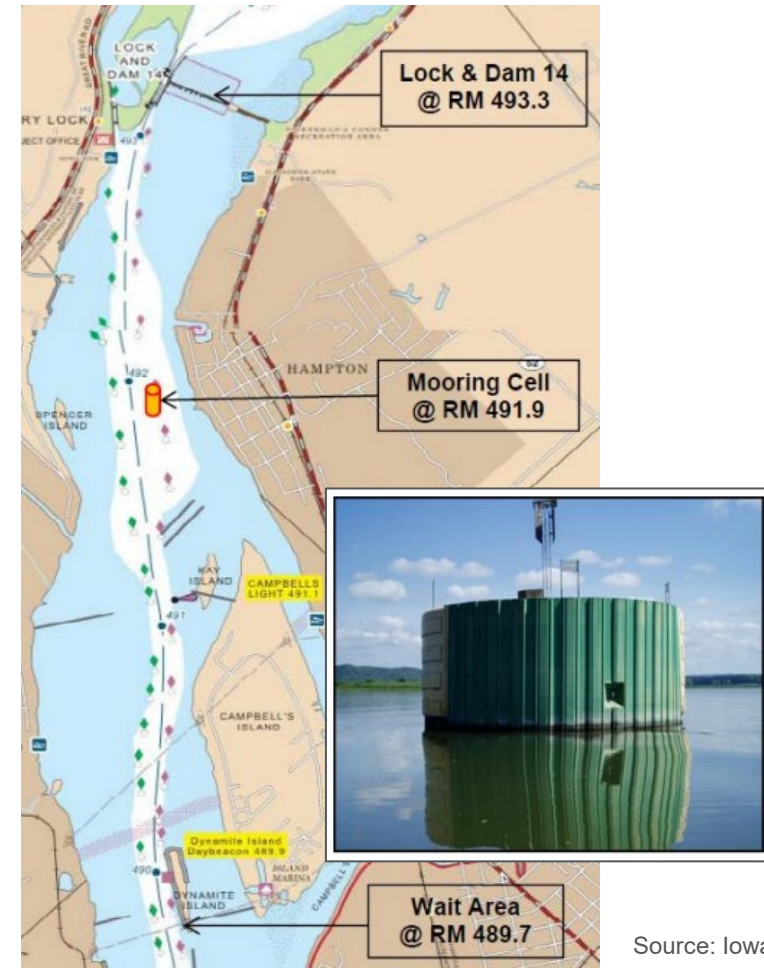



THANK YOU FOR YOUR TIME AND ATTENTION



Sam Hiscocks

Freight Planning Coordinator

515-239-1004

samuel.hiscocks@iowadot.us

Inland Ports (“Dry” Ports)

- Intermodal terminals directly connected to seaports by rail or road
 - Inland ports that provide direct rail access to seaports remove truck movements from congested highways
 - Relieves port congestion by transferring processing and distribution of goods to an inland location, away from the congested port
 - Provides flexibility and control to manufacturers running tight production lines and retailers in need of velocity and reliability in their supply chain



U.S. Department of Transportation
Federal Highway Administration



Source: SCPA

Inland Ports (“Dry” Ports) Examples



U.S. Department of Transportation
Federal Highway Administration

<i>Inland Ports</i>	<i>Attributes</i>
<i>Inland Port Dillon (South Carolina Ports Authority)</i>	<ul style="list-style-type: none">• Located along I-95, extends the Port of Charleston’s reach for importers and exporters• Offers exclusive CSX rail service on direct route to/from Port of Charleston• Importers and exporters receive one rate from ocean carriers
<i>Inland Port Greer (South Carolina Ports Authority)</i>	<ul style="list-style-type: none">• Located along I-85 between Charlotte and Atlanta, extends the Port of Charleston’s reach 212 miles for shippers and producers, including BMW’s Spartanburg plant• Offers exclusive next-day NS rail service on direct route to/from Port of Charleston
<i>Virginia Inland Port (Virginia Ports Authority)</i>	<ul style="list-style-type: none">• Brings the Port of Virginia 220 miles closer to inland markets and enhances service to the Washington D.C. / Baltimore Region by providing rail service to terminals in Hampton Roads• Offers NS rail service to/from the Port of Virginia, supporting nearby distribution centers

Inland Ports (“Pop Up” Ports)



U.S. Department of Transportation
Federal Highway Administration

- Quickly-implemented, flexible intermodal terminals directly connected to seaports by rail or road
 - Expands capacity of marine port by moving functions that would otherwise be performed there (e.g., container storage) to be performed at an inland port
- **Georgia Ports Authority “Pop Up” Container Yards**
 - Alleviates congestion at Port of Savannah by bringing cargo closer to customers and reducing length of container storage time at Port
 - Containers are transferred inland via rail and truck to flexible “pop-up” container yards in Georgia and North Carolina near manufacturing and distribution centers, as well as freight rail lines
 - Makes available valuable real estate closer to Port, freeing up dock space and speeding goods flow in and out of Port of Savannah
 - Expands container capacity by 500,000 TEUs



Source: GPA



Georgia Port Authority Appalachian Regional Port Case Study

GEORGIA PORTS AUTHORITY

DEEPWATER & INLAND TERMINAL OPTIONS- LOCATIONS



Source: Georgia Ports

GEORGIA PORTS AUTHORITY

DEEPWATER & INLAND TERMINAL OPTIONS - TERMINAL



Source: Georgia Ports

GEORGIA PORTS AUTHORITY

DEEPWATER & INLAND TERMINAL OPTIONS – NEW SITE



Source: Georgia Ports

GEORGIA PORTS AUTHORITY

DEEPWATER & INLAND TERMINAL OPTIONS - REGIONAL PORT

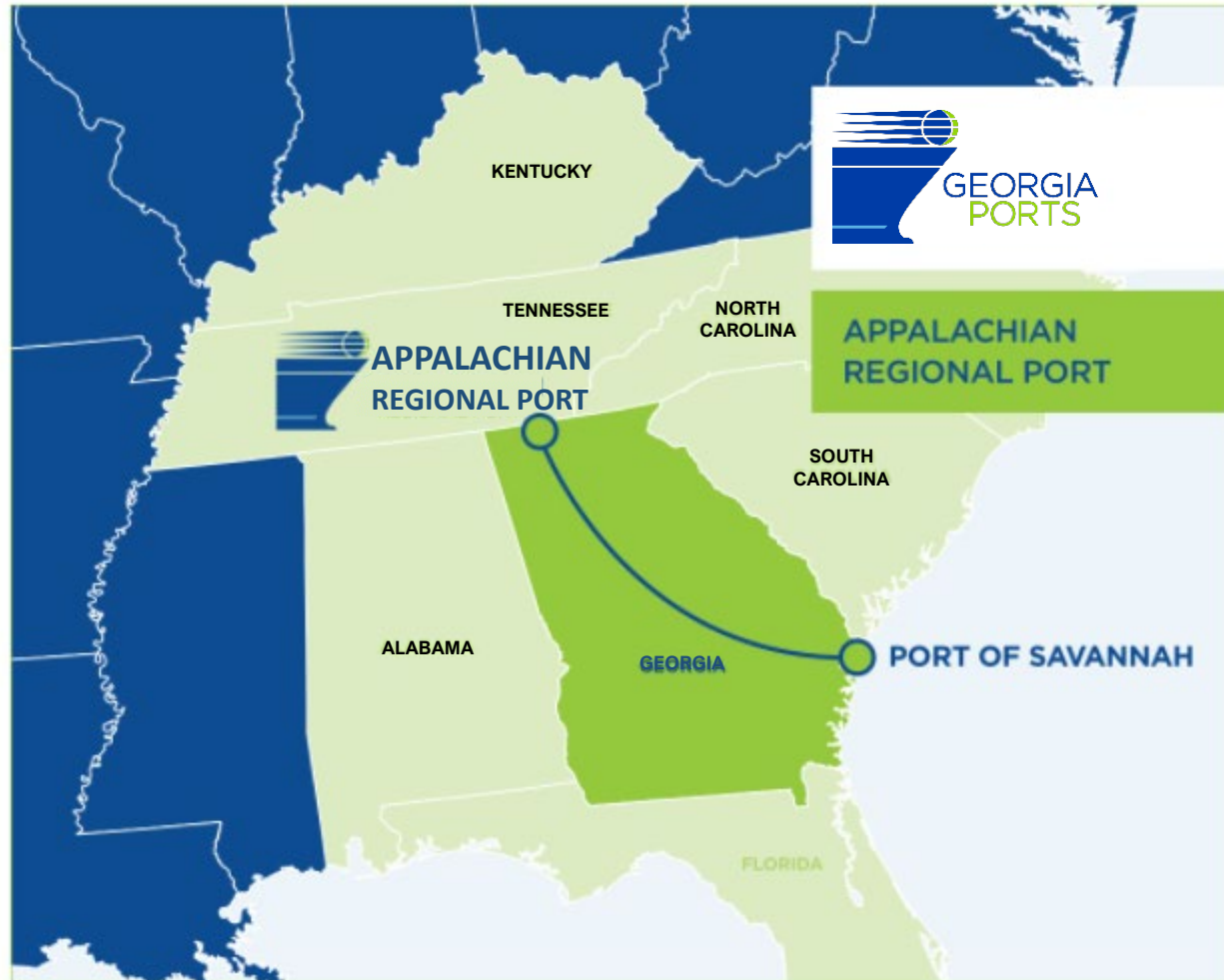

Source: Georgia Ports

GEORGIA PORTS AUTHORITY

DEEPWATER & INLAND TERMINAL OPTIONS – RAIL INTERMODAL



Source: Georgia Ports

Rail Intermodal Corridors

- Moving freight by rail, rather than by truck, can improve safety, reduce emissions, and reduce wear and tear on roads and bridges
- Containers can be double-stacked, increasing productivity and capacity
- Rail intermodal corridors are freight rail routes that provide service to inland markets from major U.S. ports
- Rail intermodal corridor initiatives expand and increase capacity on the freight rail network through investments, including:
 - Upgrading trackage and signals
 - Building intermodal terminals
 - Increasing height clearances for double stack container cars



U.S. Department of Transportation
Federal Highway Administration



Source: Norfolk Southern

Rail Intermodal Corridors Examples



U.S. Department of Transportation
Federal Highway Administration

Rail	Intermodal Corridor Projects
<i>NS Heartland Corridor Project</i>	<ul style="list-style-type: none">• Cleared double-stack overhead restrictions through 530-mile railway corridor• Raised heights of 28 tunnels, removed overhead obstacles on main lines, and added intermodal container transfer facilities• Reduced container moves by 250 route miles and decreased transit times by a day
<i>CSX National Gateway Project</i>	<ul style="list-style-type: none">• Rail infrastructure and intermodal terminal projects improved cargo flow along three major freight rail corridors operated by CSX• Increased 40 height clearances in four States to accommodate double-stack container cars through Midwest and along Atlantic coast• Parallels I-95 corridor, connecting North Carolina with Baltimore, MD, and along I-70/I-76 Corridor between Washington, DC and Northwest Ohio via Pittsburgh, PA
<i>NS Crescent Corridor</i>	<ul style="list-style-type: none">• Developed 2,500-mile rail intermodal route from New Jersey to Memphis, and New Orleans on the Gulf Coast• Built intermodal terminals in Tennessee, Alabama, and Pennsylvania and expanded two others• Constructed 300 miles of double track and ten passing sidings, straightened curves, and added signals

Rail Intermodal – Short Line Rail



U.S. Department of Transportation
Federal Highway Administration

- **Short line railroads** are smaller railroads that run shorter distances and connect shippers with larger freight rail network
- **Short line railroad infrastructure** is an underutilized asset that offers opportunities for future growth
 - Short line and regional railroads operate approximately 1/3 of the U.S. freight rail network and serve customers in 49 States
 - Short line railroads within metropolitan areas could become part of the solution to supply chain problems
 - Short line infrastructure improvements can increase first- and last-mile rail access to industries that otherwise ship by truck
 - Short line railroads haul enough carloads each year to divert 26 million trucks from the nation's highways, which relieves truck bottlenecks and is estimated to lower pavement damage costs by \$1.2 billion



Source: UP

Organization and Planning for Operations to Include Freight Stakeholders



U.S. Department of Transportation
Federal Highway Administration

- Why are Freight Stakeholders Important?
 - Serve as freight champions
 - Provide a face for freight who can build trust with industry stakeholders and public
 - Provide insights on market, economic factors, industry practices, trends, and commodity movements
 - Provide input on planning, transportation analyses, impact assessment, project selection, and operations
 - Provide consideration of impacts to other non-traditional stakeholders, such as communities near ports or other facilities

Who are Key Freight Stakeholders?

- Ports
- Railroads
- Shippers and carriers
- Third-party logistics providers
- Industrial real estate developers
- Industry associations
- Freight industry workforce
- Economic development agencies
- MPOs and local governments
- State environmental agencies
- Community organizations

Organization and Planning for Operations to Include Freight Stakeholders (continued)



U.S. Department of Transportation
Federal Highway Administration

- Stakeholder engagement
 - Freight advisory committees
 - Interviews
 - Surveys
 - Information sharing
 - Feedback loops (e.g., reviews, updates)
- Successes
 - *Texas DOT's Freight Advisory Committee* – industry support, buy in, and project advancement, especially in emerging automation technologies
 - *North Jersey Transportation Planning Authority* – produced numerous resources to describe freight flows, gained support from stakeholders, led to new funding programs



Source: LACMTA

Operations and Freight Performance Measurement and Management



U.S. Department of Transportation
Federal Highway Administration

- Visualization Tools
 - Convey freight performance to tell a freight story to multiple audiences and stakeholders
 - Allow freight bottlenecks to be seen and experienced dynamically
- Geospatial Tools
 - Show freight bottlenecks in relation to freight generators along with traffic volumes and asset conditions
 - Help agencies identify causes of bottlenecks and tailor solutions
- Freight Performance Data
 - Use of big data, connected options (e.g., probe) helps fuel performance measures and identify bottlenecks, particularly when relying on delay per mile
 - Conflation to Highway Performance Management System (HPMS) networks helps to view measure results with other roadway information like pavement and safety

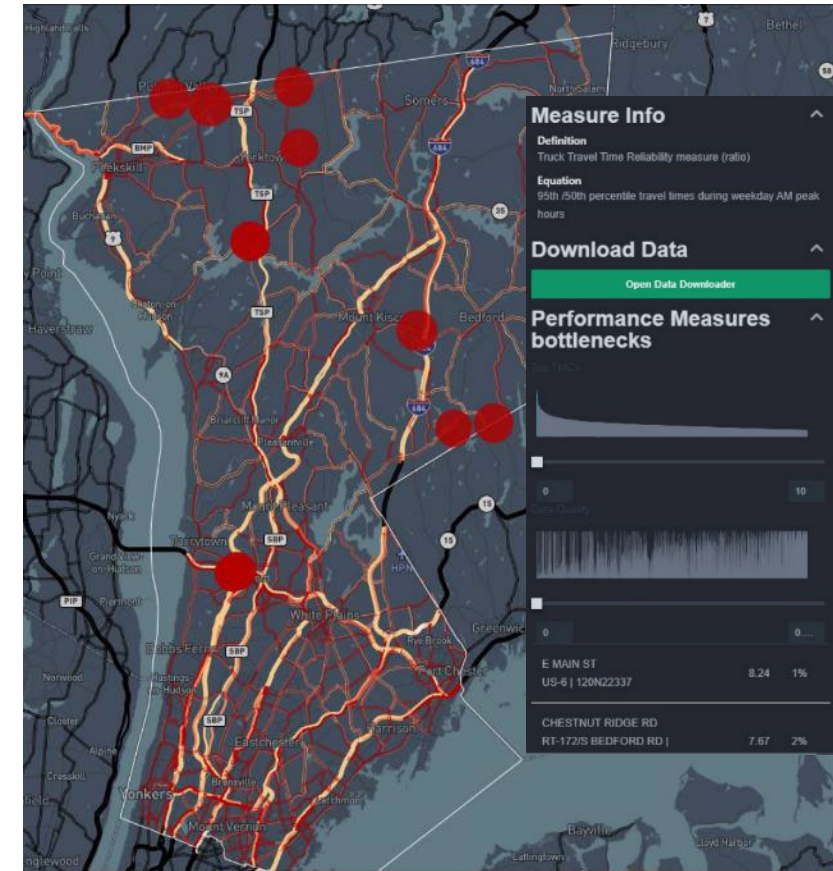

Source: NYSDOT



Texas and Maryland Freight Performance Visualization Case Study



Truck Congestion Analysis Tool (TCAT)

Analysis tool based on Speed Data and Local Traffic Volumes



- Planning tools for analyzing and monitoring congestion, primarily focused on truck congestion and roadway performance
- Totally open source coding and programming
 - No license, registration fees
 - Fully customizable
 - Can be transferred to sponsor agency/organization for hosting





- Produced as part of the Texas 100 Most Congested Roadways effort between TTI and TxDOT
- Contains traditional mobility performance measures on annual basis for both all-vehicle and truck-only
 - Delay
 - Delay per mile
 - Congestion cost
 - Travel time index
 - Planning time index
 - Others





- All measures are stored on agency's network (RHiNo) at the road segment level
 - Flexibility in creating custom corridors
 - Provides for better relationships to other RHiNo road segment characteristics and other agency datasets
 - Sections can be saved and monitored from year-to-year
 - If speed data is not available, speeds are estimated from like segments
- All measures are speed and volume-based:
 - INRIX speed data
 - XD network conflated to RHiNo with INRIX speed data associated to RHiNo
 - RHiNo network
 - Provides roadway geometry, traffic volumes



- Covers most roadways non-local roads in Texas
 - Over 241,000 road segments covering 106,000+ centerline miles of roadway across the State
 - One subset is the 10,000+ centerline miles monitored in the Texas 100 list
- Multiple years of data (2016 through 2019)





- Various regions/geographies
 - County
 - TxDOT district
 - MPO regions
 - Other significant regions
 - Key pre-defined corridors
- Key parameters summarized across the region/geography in tabular form by:
 - Route
 - Highway system
 - Functional class
 - Rural/urban
 - Other geographies (county, district)

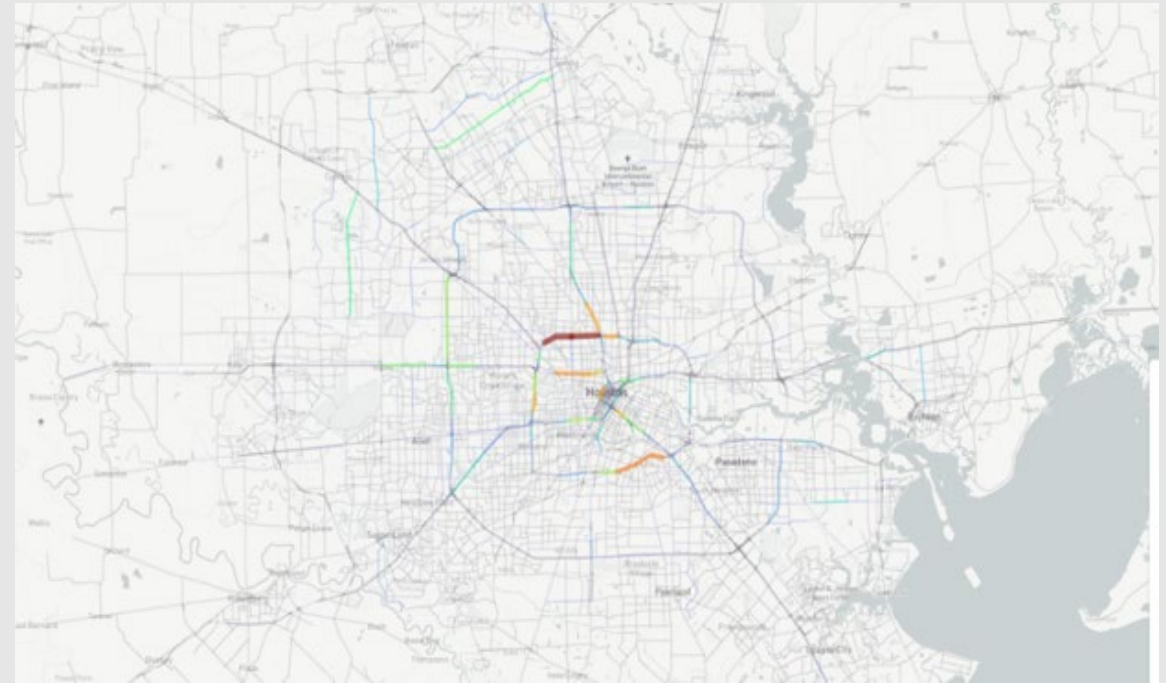

ROAD SEGMENTS SUMMARY CUSTOM SUMMARY OTHER MAP LAYERS								
Functional Classification	Truck Vehicle Hours of Delay	Truck Planning Time Index 80	Truck Planning Time Index 95	Truck AADT	Truck Vehicle Miles of Travel	Truck Reference Speed	Truck Congested Speed	Truck Travel Time Index
Interstate	4,004,518	1.621	1.774	9,613.61	1,404,303	63.373	54.183	1.316
Other Freeway and Expressway	1,168,435	1.351	1.471	4,989.314	793,328	63.092	57.444	1.157
Other Principal Arterial	2,992,131	1.402	1.511	1,130.652	571,391	46.293	40.251	1.218
Minor Arterial	3,030,465	1.411	1.518	636.973	474,691	39.182	33.021	1.236
Major Collector	2,191,389	1.402	1.531	322.336	415,130	43.429	37.431	1.21
Minor Collector	18,410	1.16	1.259	92.449	8,062	46.426	43.638	1.078



- Users create corridors real time by selecting starting and ending segments
- Road segment data is aggregated to form one set of results

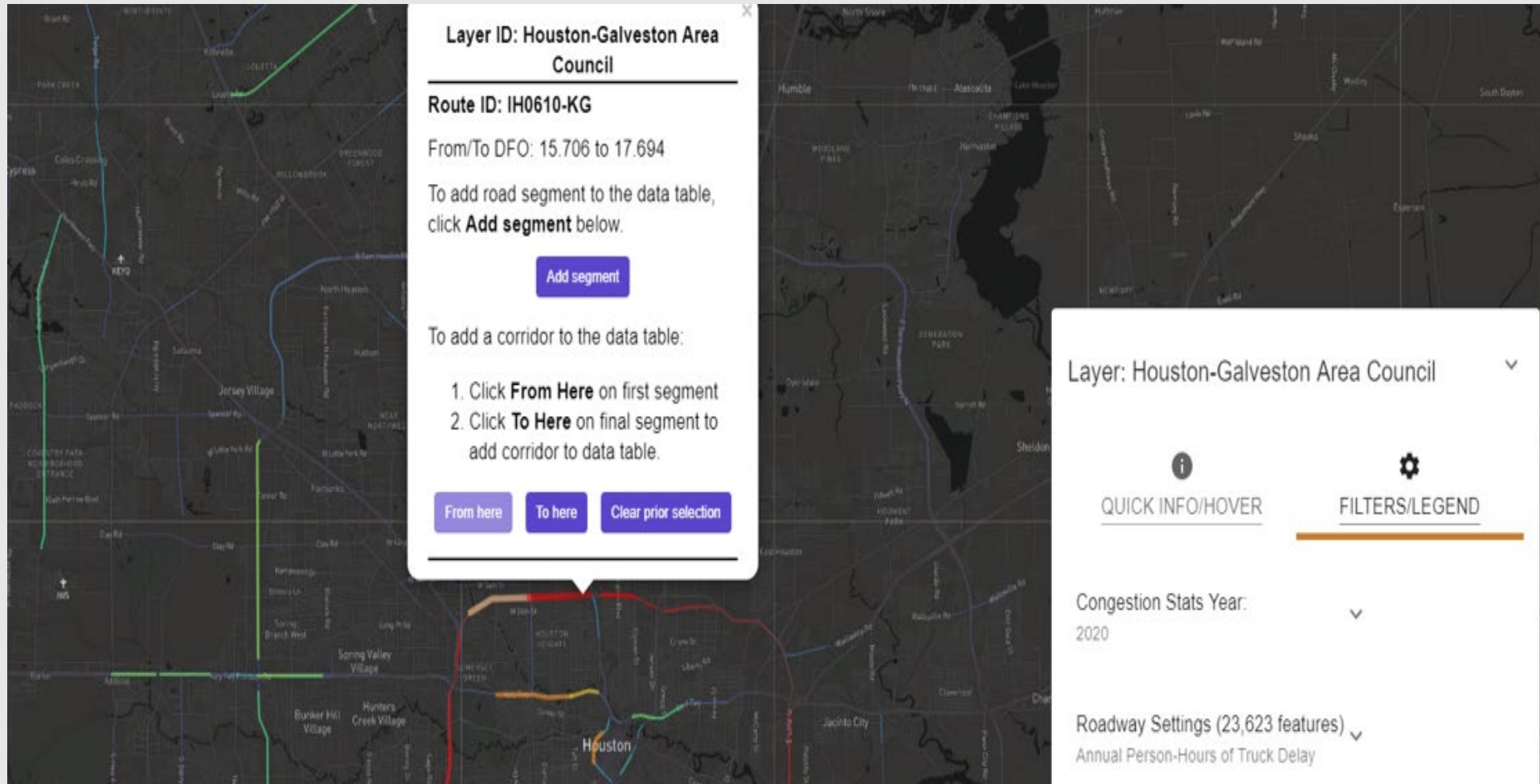

Texas Top 100 Congested Roadways



- Monitored Road Segments
 - ~ 1,800 segments covering ~ 10,000 centerline miles from all urban areas
- Top 100 Truck congested road segments
- Top 100 overall congested road segments for reference
- Summary stats are included in tabular form
- Ranking trends are included in graphical form

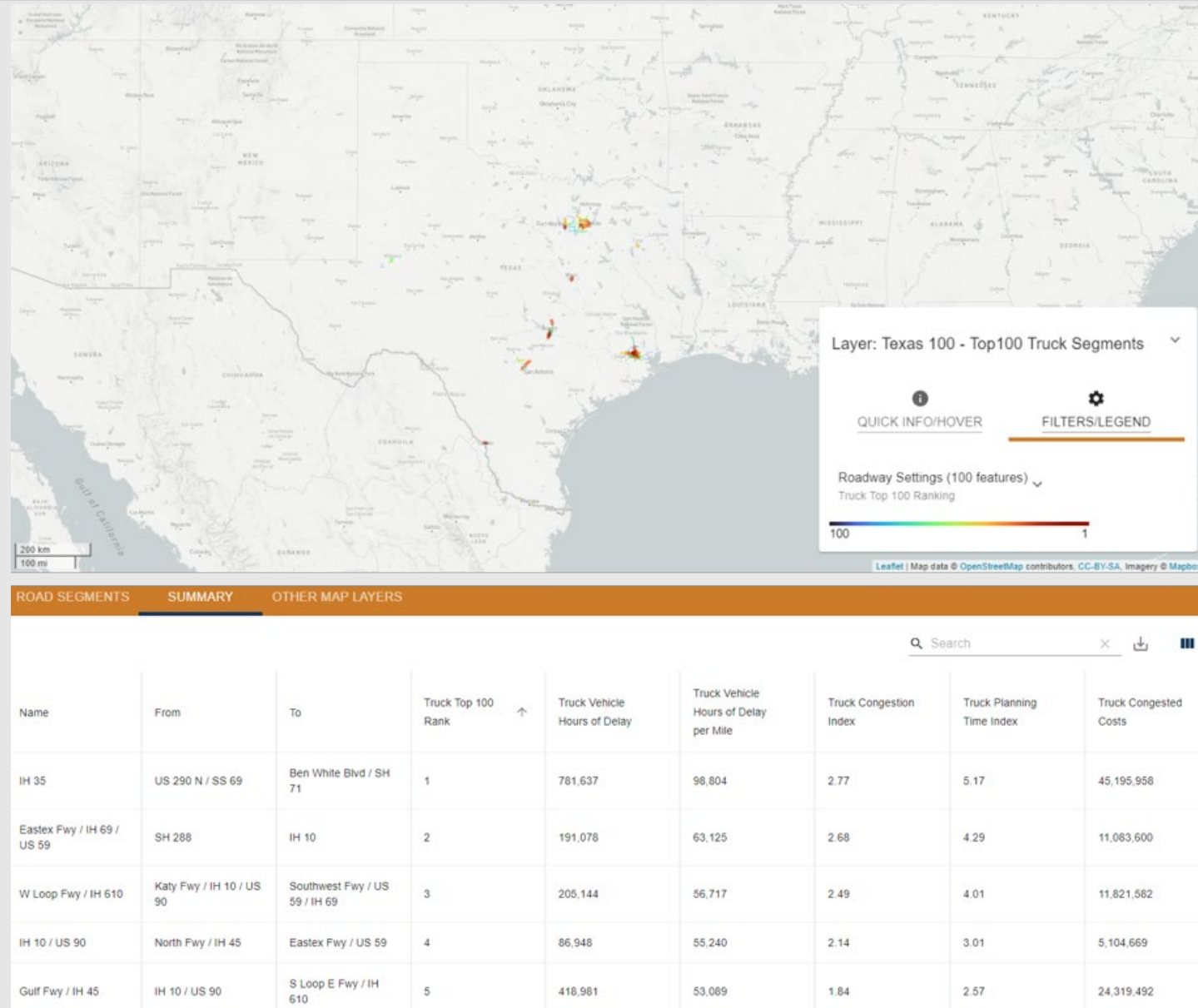

3-D Mapping



- Allows users to better visualize roadway performance
- Map orientation can be changed to dynamically view the area from different perspectives

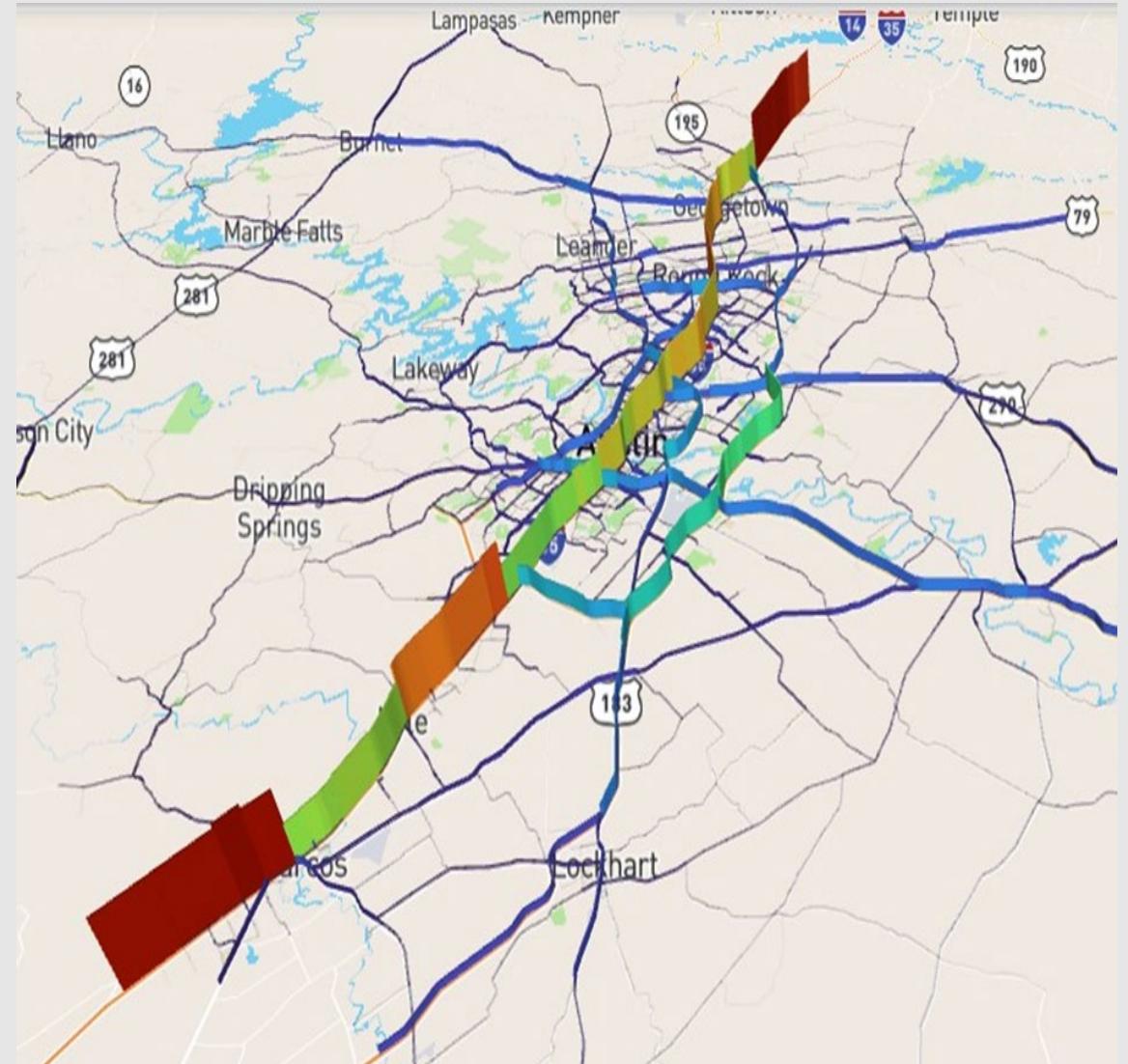

TCAT – Annual Truck Congestion Report Cards



2019 Texas Truck Congestion Report Card



- Extension of performance measure summaries
- Provides quick access to both interactive and printable (pdf and images for presentations) summary reports
- Available for all geographies/regions included in TCAT

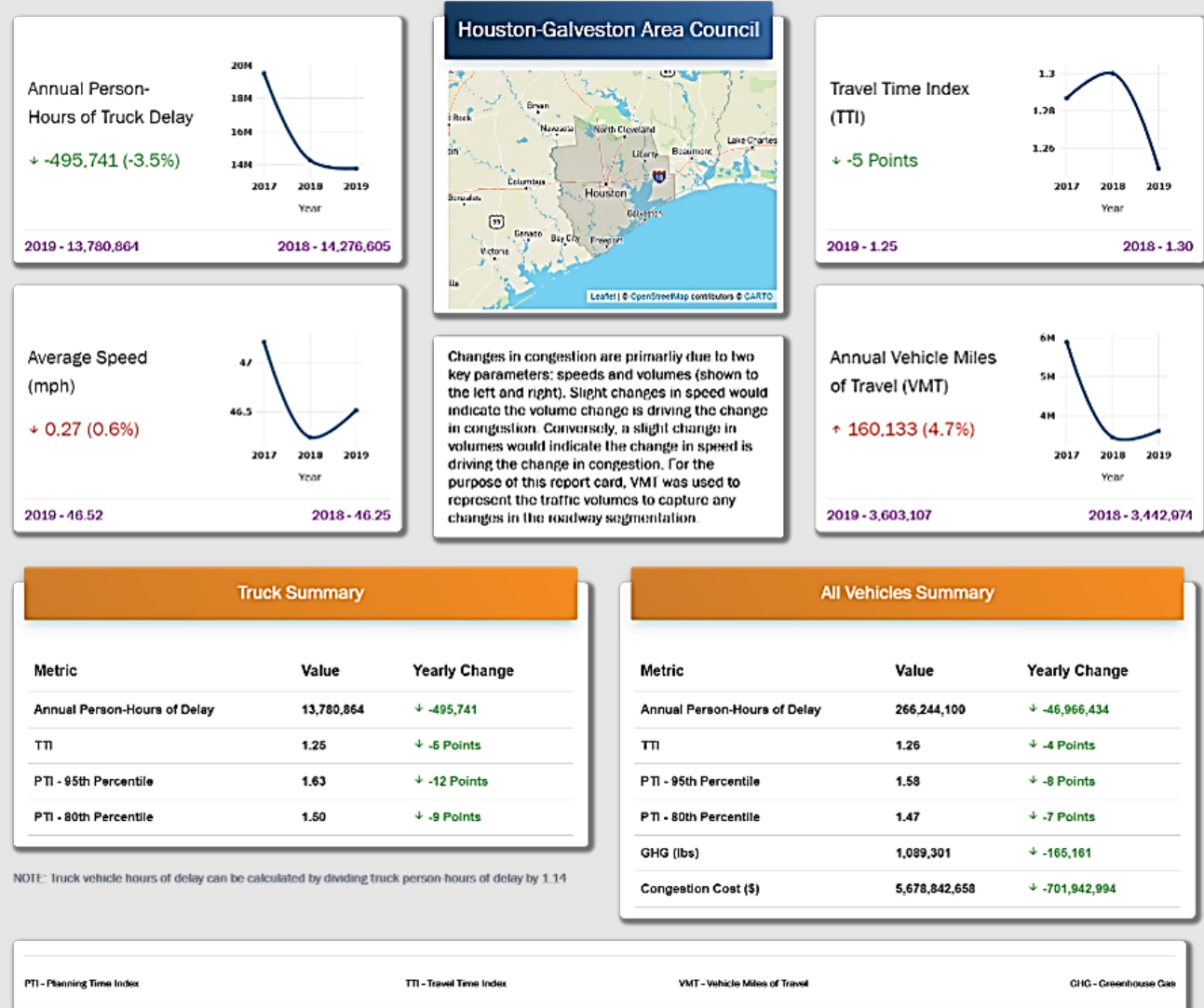

MARYLAND ROADWAY PERFORMANCE TOOL (MRPT)

Toria Lassiter
Assistant Division Chief, Innovative Performance Planning Division
Office of Planning and Preliminary Engineering
State Highway Administration

WHAT IS MRPT?

- Tool for visualizing all traffic and freight.
- Aligned with Highway Performance Monitoring System (HPMS) and Geographic Information System (GIS) information.
- Ranks top bottlenecks using delay per mile, data do the talking.
- Performance statistics can be calculated by segment or:
 - Different geographics (regional, county)
 - Ownership
 - Functional class
 - Network (e.g., STRAHNET, Freight Network)
- Includes a suite of measures and data coded to HPMS.

WHY MRPT?

- Visualizing performance is critical to doing something about it.
- It is important to have data aligned with HPMS (One Maryland One Centerline) for analytics.
- Dashboards help engage diverse stakeholders.
- MRPT allows a suite of measures applied for all Maryland highway segments.
- MRPT provides top ranked bottlenecks based on Delay per Mile, but can rank by other measures as well.

TOP TRUCK BOTTLENECKS



Maryland Roadway Performance Tool

Current Layer: Top 100 Bottlenecks

Select geographic layer:

- Top 100 Bottlenecks
- Regions
- Counties
- Freight Network
- Critical Corridors Freeway
- Critical Corridors Arterial
- Critical Corridors Freight

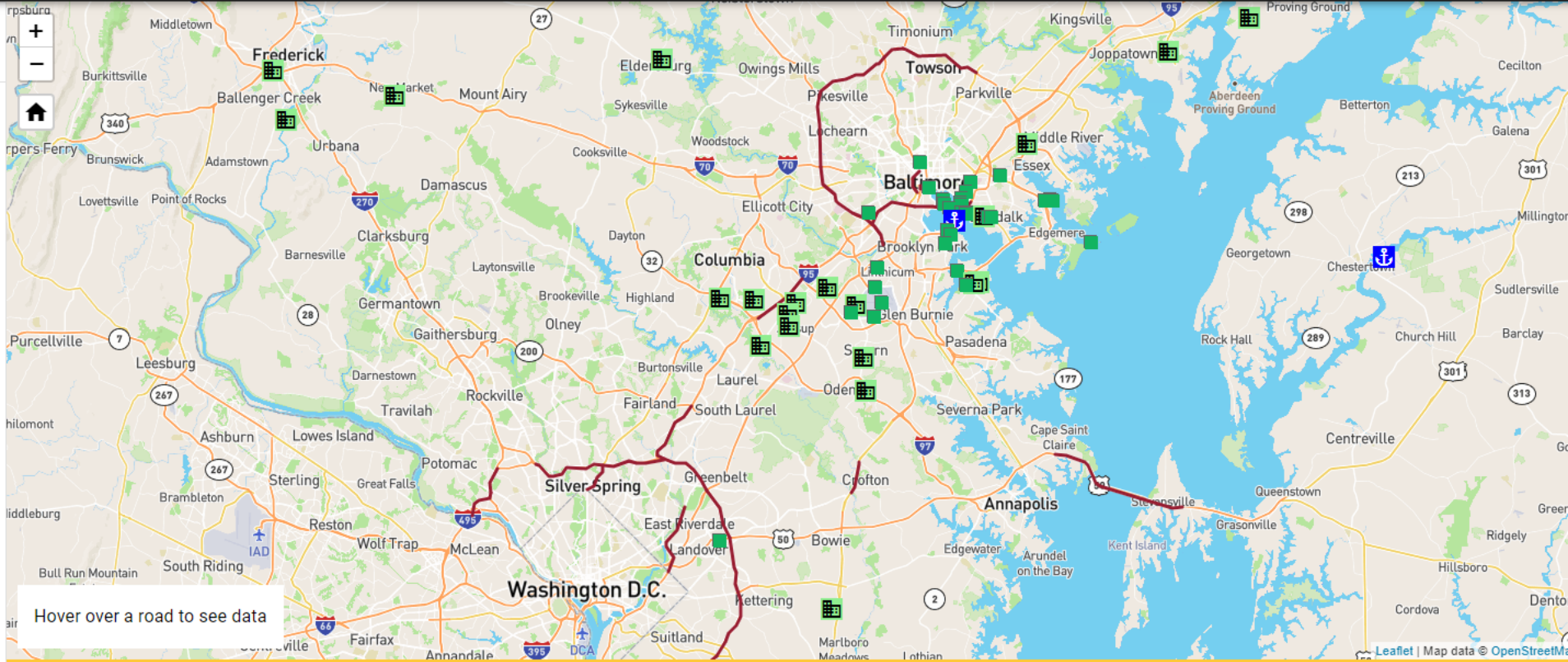

SETTINGS/FILTERS ROAD SEGMENTS SUMMARY

Data Year: 2019 ^

Top 100 Bottlenecks Rankings ^

TOP TRUCK BOTTLENECK RANKING DETAIL



Maryland Roadway Performance Tool

Current Layer: Top 100
Bottlenecks

Select geographic layer:

- Top 100 Bottlenecks
- Regions
- Counties
- Freight Network
- Critical Corridors Freeway
- Critical Corridors Arterial
- Critical Corridors Freight

Year: 2019

- Top 100 Bottlenecks Rank: 169
- Person Hours of Delay: 1,118,880
- Person Hours of Delay per Mile: 113,835
- Congested Costs: 25,997,741
- TTTR - Estimated: 1.622
- IRI - Weighted by Lanemiles: 115
- Commodity Values (Annual \$1,000,000): 63,465

Route ID: US 50

From/To: MD 179 to MD 18 / MD18H

Click segments to add to data table

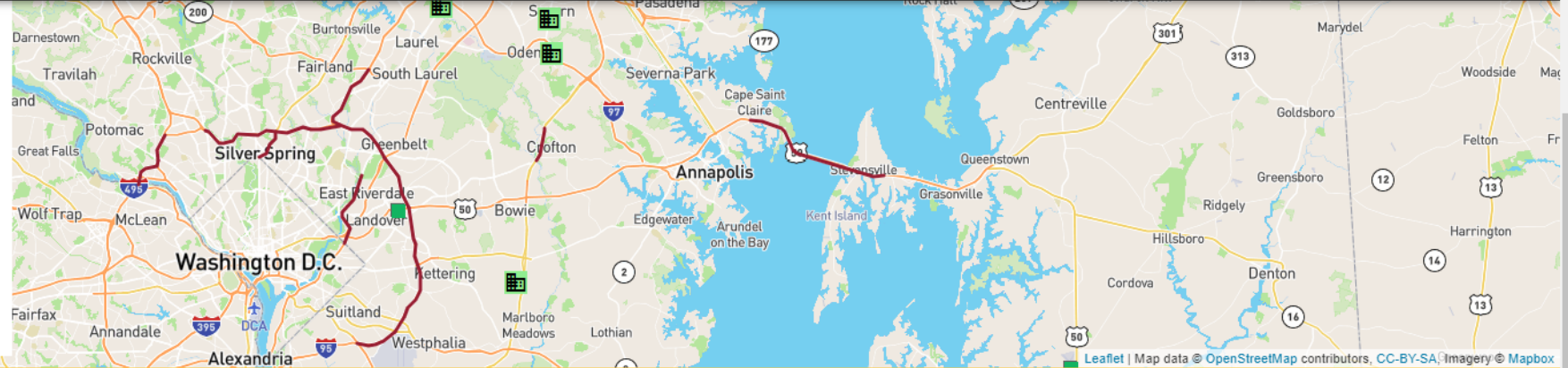

SETTINGS/FILTERS ROAD SEGMENTS **SUMMARY**

	Road	From	To	Truck Top 100 Bottlenecks Rank	Truck Person-Hours of Delay	Truck Person-Hours of Delay per Mile	Truck Travel Time Index	Truck Planning Time Index 95	Truck Congested Costs	IRI - Weighted by VMT	Commodity Values (Annual \$1,000,000)
Show	MU 1700 / IS 395	MU 4295 / CAMDEN ST	MU 1395 / E LOMBARD ST	1	6,816	42,599	1.93	4.57	320,061	250	5,935
Show	IS 495	CO 14 / CHERRY HILL RD	MD 355	2	327,479	34,764	1.56	3.53	15,572,042	90	77,072
Show	IS 495 / IS 95	MD 190	IS 270 / IS 270Y	3	60,016	34,492	1.38	3.08	2,845,197	56	98,820
Show	GV 6 / CLARA

Source: MDOT



TOTAL MARYLAND FREIGHT NETWORK PERFORMANCE



Maryland Roadway Performance Tool

Current Layer: Maryland Freight Network (including critical corridors)

Select geographic layer:

- Top 100 Bottlenecks
- Regions
- Counties
- Freight Network
- Critical Corridors Freeway
- Critical Corridors Arterial
- Critical Corridors Freight

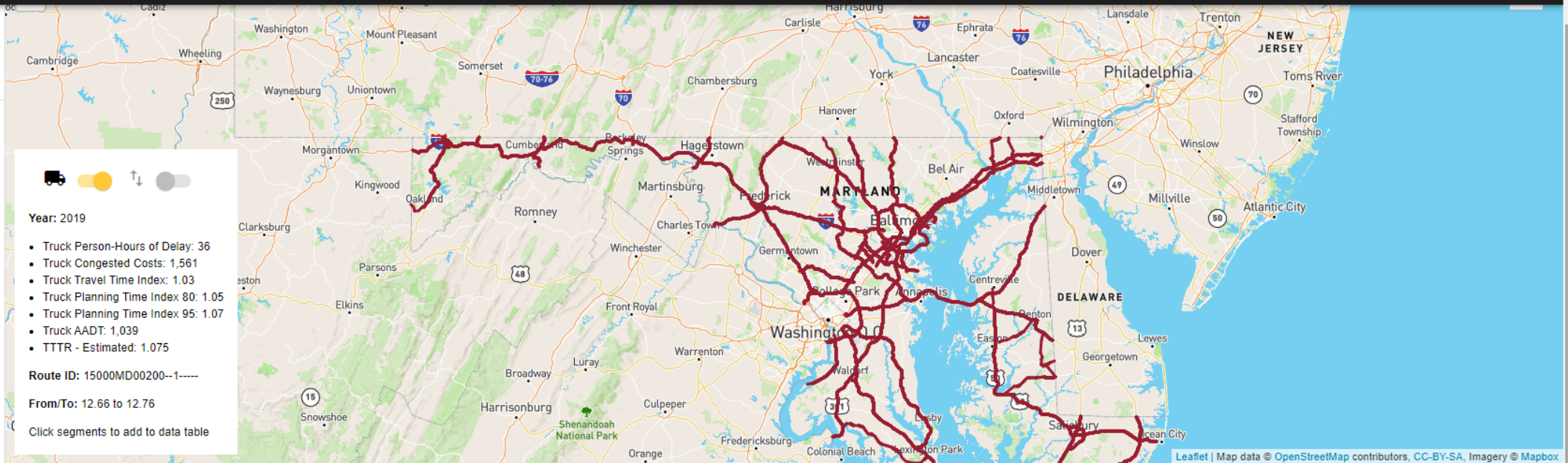

SETTINGS/FILTERS ROAD SEGMENTS SUMMARY

Total	Congested Costs	Congested CO2 Lbs	Normal CO2 Lbs	Truck Person-Hours of Delay	Truck Planning Time Index 95	Truck Congested Costs	Commodity Values (Annual \$1,000,000)	IRI - Weighted by VMT
Show	1,830,183,940	193,384	13,716,412	2,598,792	1.704	125,999,825	577,311,661.034	78.138

Source: MDOT



TRUCK PARKING DASHBOARD WITH TRIPS

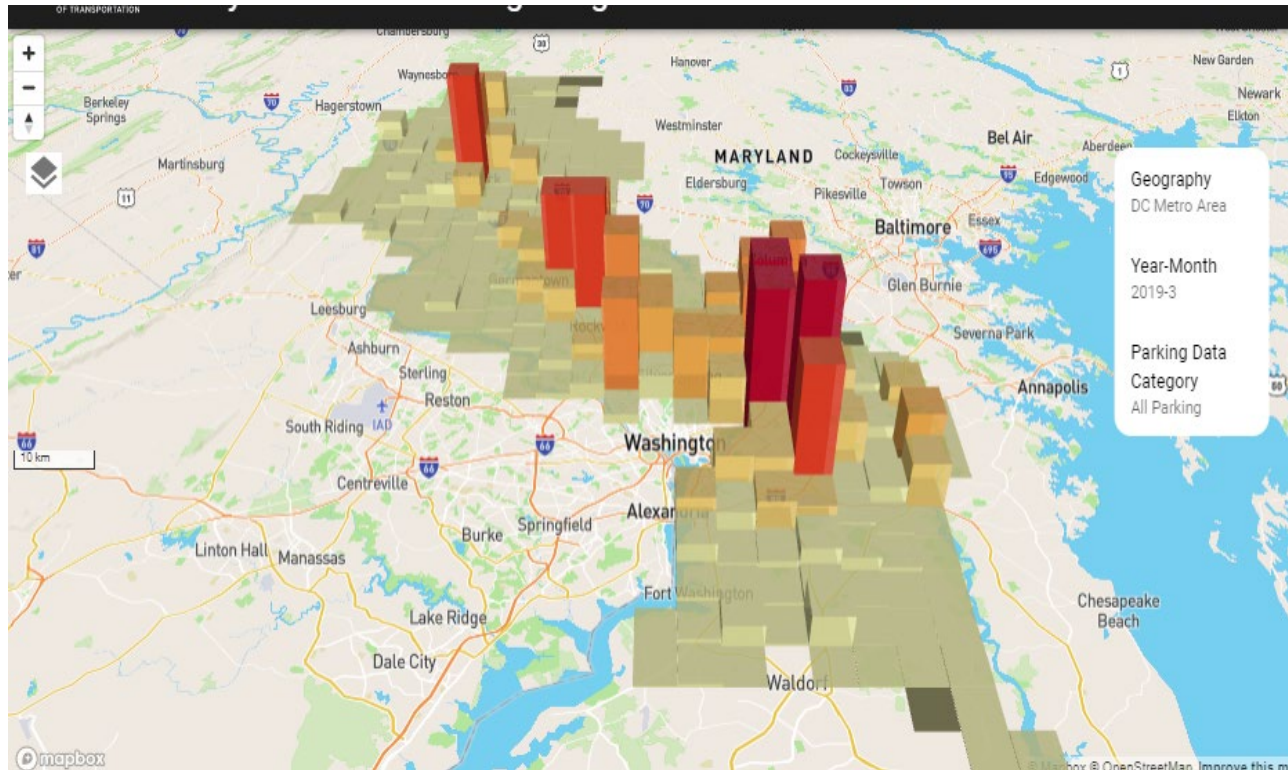

Source: MDOT

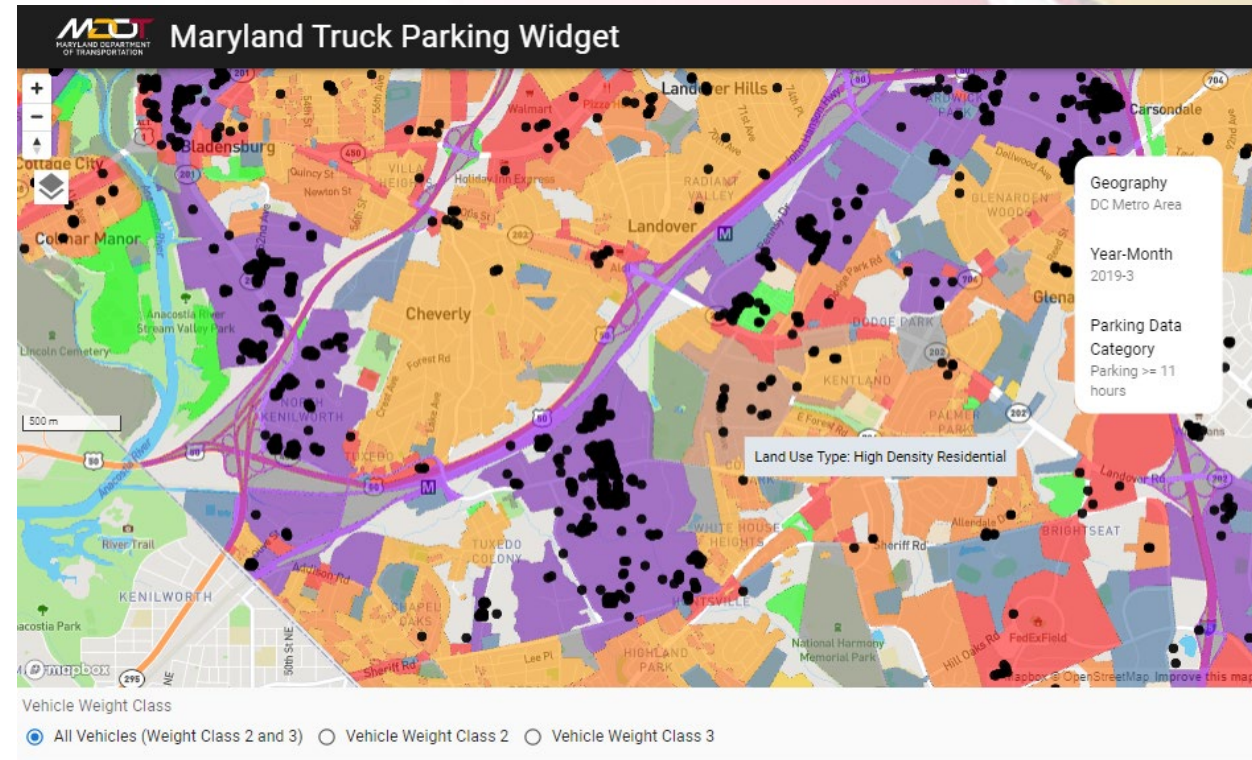

Source: MDOT

FOR MORE INFORMATION

Toria Lassiter

Assistant Division Chief, Performance and Asset Management

Innovative Performance Planning Division

Office of Planning and Preliminary Engineering

Maryland DOT State Highway Administration

tlassiter@mdot.state.md.us

410-545-5731

MRPT Beta Version: <https://mrptui.z21.web.core.windows.net/>



Conclusion



U.S. Department of Transportation
Federal Highway Administration

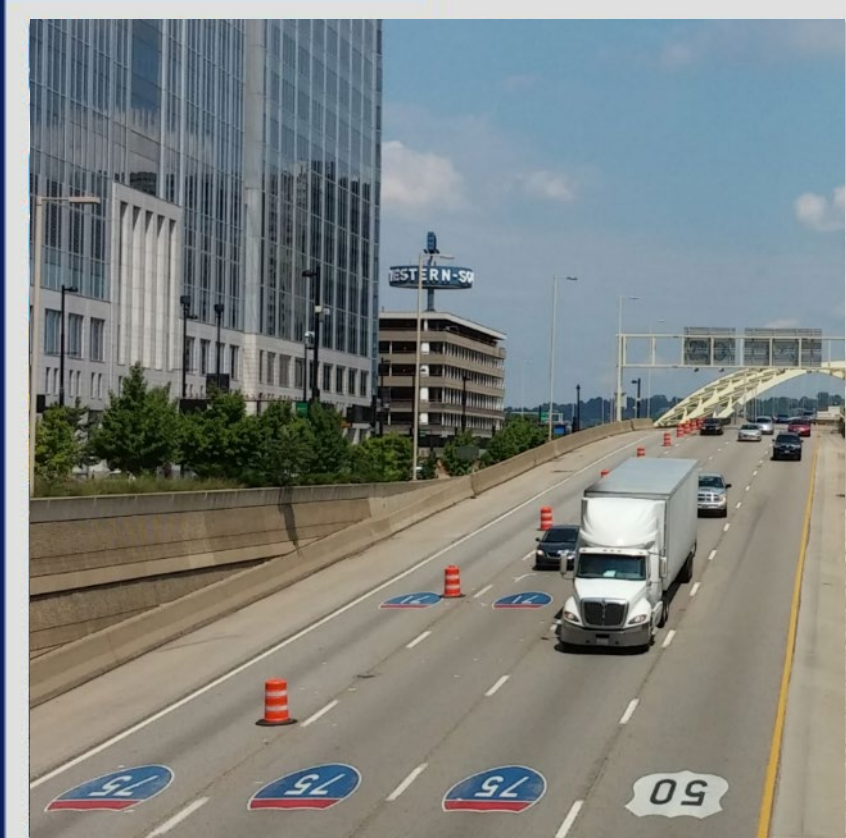

For more information:

Jeff Purdy
Freight Management and Operations
Office of Operations
Jeffrey.Purdy@dot.gov

<https://ops.fhwa.dot.gov/freight>