

# Bridge Structure Comparative Analysis Technical Report

**Comprehensive  
Truck Size and  
Weight Limits  
Study**

June 2015



U.S. Department  
of Transportation

**Federal Highway  
Administration**

## EXECUTIVE SUMMARY

### **Background**

This report documents analyses conducted as part of the U.S. Department of Transportation (USDOT) *2014 Comprehensive Truck Size and Weight Limits Study* (2014 CTSW Study). As required by Section 32801 of MAP-21 [Moving Ahead for Progress in the 21st Century Act (P.L. 112-141)], Volumes I and II of the 2014 CTSW Study have been designed to meet the following legislative requirements:

- Subsection 32801 (a)(1): Analyze accident frequency and evaluate factors related to accident risk of vehicles to conduct a crash-based analyses, using data from States and limited data from fleets;
- Subsection 32801 (a)(2): Evaluate the impacts to the infrastructure in each State including the cost and benefits of the impacts in dollars; the percentage of trucks operating in excess of the Federal size and weight limits; and the ability of each State to recover impact costs;
- Subsection 32801 (a)(3): Evaluate the frequency of violations in excess of the Federal size and weight law and regulations, the cost of the enforcement of the law and regulations, and the effectiveness of the enforcement methods;
- Subsection 32801 (a)(4): Assess the impacts that vehicles have on bridges, including the impacts resulting from the number of bridge loadings; and
- Subsections 32801 (a)(5) and (6): Compare and contrast the potential safety and infrastructure impacts of the current Federal law and regulations regarding truck size and weight limits in relation to six-axle and other alternative configurations of tractor-trailers; and where available, safety records of foreign nations with truck size and weight limits and tractor-trailer configurations that differ from the Federal law and regulations. As part of this component of the study, estimate:
  - (A) the extent to which freight would likely be diverted from other surface transportation modes to principal arterial routes and National Highway System intermodal connectors if alternative truck configuration is allowed to operate and the effect that any such diversion would have on other modes of transportation;
  - (B) the effect that any such diversion would have on public safety, infrastructure, cost responsibilities, fuel efficiency, freight transportation costs, and the environment;
  - (C) the effect on the transportation network of the United States that allowing alternative truck configuration to operate would have; and
  - (D) the extent to which allowing alternative truck configuration to operate would result in an increase or decrease in the total number of trucks operating on principal arterial routes and National Highway System intermodal connectors.

To conduct the study, the USDOT, in conjunction with a group of independent stakeholders, identified six different vehicle configurations involving six-axle and other alternative configurations of tractor-trailer as specified in Subsection 32801 (a)(5), to assess the likely results of allowing widespread alternative truck configurations to operate on different highway

networks. The six vehicle configurations were then used to develop the analytical scenarios for each of the five comparative analyses mandated by MAP-21. The use of these scenarios for each of the analyses in turn enabled the consistent comparison of analytical results for each of the six vehicle configurations identified for the overall study.

The results of this *2014 Comprehensive Truck Size and Weight Limits Study* (2014 CTSW Study) study are presented in a series of technical reports. These include:

- *Volume I: Comprehensive Truck Size and Weight Limits Study – Technical Summary Report.* This document gives an overview of the legislation and the study project itself, provides background on the scenarios selected, explains the scope and general methodology used to obtain the results, and gives a summary of the findings.
- *Volume II: Comprehensive Truck Size and Weight Limits Study.* This volume comprises a set of the five comparative assessment documents that meet the technical requirements of the legislation as noted:
  - *Modal Shift Comparative Analysis* (Subsections 32801 (a)(5) and (6)).
  - *Pavement Comparative Analysis* (Section 32801 (a)(2)).
  - *Highway Safety and Truck Crash Comparative Analysis* (Subsection 32801 (a)(1)).
  - *Compliance Comparative Analysis* (Subsection 32801 (a)(3)).
  - *Bridge Structure Comparative Analysis* (Subsection 32801 (a)(4)).

This *Volume II: Bridge Structure Comparative Analysis* describes the methodology used and presents the results of an assessment to ascertain the impacts that certain alternative configurations may have on the bridge structures on the National Highway System (NHS), including the Interstate System. It also estimates the impacts that trucks operating at or below current Federal limits have on bridge infrastructure as compared with trucks operating above those limits.

### **Purpose of the Bridge Structures Analysis**

The main objective of this report is to determine and assess the implications of the structural demands on U.S. bridges under six alternative truck configuration scenarios analyzed in the US Department of Transportation USDOT 2014 CTSW Study. The scope of this study includes both the immediate structural effects on the existing bridge inventory (**Chapter 3**) and the bridge capital cost effects that would accrue over time due to that change (**Chapter 5**). This study includes an assessment of one-time bridge costs that may be incurred as a result of posting issues (see **Chapter 4**) and related strengthening or replacement of bridges (see **Chapter 6**), as indicated by the analysis.

Potential modal shifts associated with six different truck size and weight policy options (scenarios) are addressed in this report, but for a more thorough analysis and discussion, please see *Volume II: Modal Shift Comparative Analysis*.

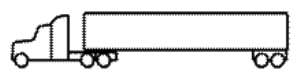
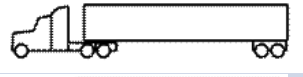




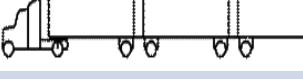

**Table ES-1** shows the vehicles that would be allowed under each scenario as well as the current vehicle configurations (the control vehicles) that operate within the 80,000 lb. maximum gross vehicle weight (GVW) allowed under Federal limits.

The first three scenarios assess tractor semitrailers that are heavier than generally allowed under currently Federal law. Scenario 1 assesses a 5-axle (3-S2) tractor-semitrailer operating at a GVW of 88,000 pound, while Scenarios 2 and 3 assess 6-axle (3-S3) tractor semitrailers operating at GVWs of 91,000 and 97,000 pounds, respectively. The control vehicle for these scenario vehicles is the 5-axle tractor-semitrailer with a maximum GVW of 80,000 pounds. This is the most common vehicle configuration used in long-haul over-the-road operations and carries the same kinds of commodities expected to be carried in the scenario vehicles.

Scenarios 4, 5, and 6 examine vehicles that would serve primarily less-than-truckload (LTL) traffic that currently is carried predominantly in five-axle (3-S2) tractor-semitrailers and five - axle (2-S1-2) twin trailer combinations with 28 or 28.5-foot trailers and a maximum GVW of 80,000 pounds. Scenario 4 examines a five-axle (2-S1-2) double trailer combination with 33-foot trailers with a maximum GVW of 80,000 pounds. Scenarios 5 and 6 examine triple trailer combinations with 28.5-foot trailer lengths and maximum GVWs of 105,500 (2-S1-2-2) and 129,000 (3-S2-2-2) pounds, respectively. The five-axle twin trailer with 28.5-foot trailers (2-S1-2) is the control vehicle for Scenarios 4, 5, and 6 since it operates in much the same way as the scenario vehicles are expected to operate.

At this point it is important to note that for the purposes of the study the control double has an approved GVW of 80,000 pounds; however, the GVW used for the control double in the study is 71,700 pounds based on data collected from weigh-in motion (WIM)-equipped weight and inspection facilities and is a more accurate representation of actual vehicle weights than the Surface Transportation Assistance Act (STAA)-authorized GVW. Using the WIM-derived GVW also allows for a more accurate representation of the impacts generated through the six scenarios.

**Table ES-1: Truck Configuration and Weight Scenarios Analyzed in the 2014 CTSW Study**

Scenario	Configuration	Depiction of Vehicle	# Trailers or Semi-trailers	# Axles	Gross Vehicle Weight (pounds)	Roadway Networks
<b>Control Single</b>	5-axle vehicle tractor, 53 foot semitrailer (3-S2)		1	5	80,000	STAA <sup>1</sup> vehicle; has broad mobility rights on entire Interstate System and National Network including a significant portion of the NHS
1	5-axle vehicle tractor, 53 foot semitrailer (3-S2)		1	5	88,000	Same as Above
2	6-axle vehicle tractor, 53 foot semitrailer (3-S3)		1	6	91,000	Same as Above
3	6-axle vehicle tractor, 53 foot semitrailer (3-S3)		1	6	97,000	Same as Above
<b>Control Double</b>	Tractor plus two 28 or 28 ½ foot trailers (2-S1-2)		2	5	80,000 maximum allowable weight 71,700 actual weight used for analysis <sup>2</sup>	Same as Above
4	Tractor plus twin 33 foot trailers (2-S1-2)		2	5	80,000	Same as Above
5	Tractor plus three 28 or 28 ½ foot trailers (2-S1-2-2)		3	7	105,500	74,500 mile roadway system made up of the Interstate System, approved routes in 17 western states allowing triples under ISTEA Freeze and certain four-lane PAS roads on east coast <sup>3</sup>
6	Tractor plus three 28 or 28 ½ foot trailers (3-S2-2-2)		3	9	129,000	Same as Scenario 5 <sup>3</sup>

<sup>1</sup>The STAA network is the National Network (NN) for the 3-S2 semitrailer (53') with an 80,000-lb. maximum GVW and the 2-S1-2 semitrailer/trailer (28.5') also with 80,000 lbs. maximum GVW vehicles. The alternative truck configurations have the same access off the network as its control vehicle.

<sup>2</sup>The 80,000 pound weight reflects the applicable Federal gross vehicle weight limit; a 71,700 gross vehicle weight was used in the Study based on empirical findings generated through an inspection of the weigh-in-motion data used in the Study.

<sup>3</sup>The triple network is 74,454 miles, which includes the Interstate System, current Western States' triple network, and some four-lane highways (non-Interstate System) in the East. This network starts with the 2000 CTSW Study Triple Network and overlays the 2004 Western Uniformity Scenario Analysis, Triple Network in the Western States. There had been substantial stakeholder input on networks used in these previous USDOT studies and use of those provides a degree of consistency with the earlier studies. The triple configurations would have very limited access off this 74,454 mile network to reach terminals that are immediately adjacent to the triple network. It is assumed that the triple configurations would be used in LTL line-haul operations (terminal to terminal). The triple configurations would not have the same off network access as its control vehicle—2-S1-2, semitrailer/trailer (28.5'), 80,000 lbs. GVW. The 74,454 mile triple network includes: 23,993 mile network in the Western States (per the 2004 Western Uniformity Scenario Analysis, Triple Network), 50,461 miles in the Eastern States, and mileage in Western States that was not on the 2004 Western Uniformity Scenario Analysis, Triple Network but was in the 2000 CTSW Study, Triple Network (per the 2000 CTSW Study, Triple Network).

## **Methodology**

There are several aspects to impacts to bridges caused by heavy trucks: structural impacts, fatigue impacts and bridge deck wear. Comparative analyses for two of the three cited areas were completed. The lack of a bridge deck impact model suited for estimating the bridge deck wear caused by commercial motor vehicles of various gross vehicle weights limited the ability of the USDOT study team to evaluate the consumption of bridge deck service life attributed to specific configurations and alternative GVWs.

As a result, this report assesses bridge structures and fatigue in the context of the two, 80,000 lb. control vehicles; the six proposed alternative truck configuration scenarios; two Regions, as best defined for bridge analysis purposes; and two primary Highway Networks, again as defined for bridge analysis purposes.

The study team first screened the National Bridge Inventory (NBI) to determine both the total bridge count and the relative number of bridges by bridge type that are on the two subject highway networks: the Interstate System (IS) and other NHS roadways. The 12 most common bridge types were chosen for inclusion in the structural portion of the study, representing 96 percent of all bridges. AASHTO's *AASHTOWare Bridge Rating*® (ABrR, formerly VIRTIS) structural analysis program was used to analyze more than 500 representative bridges. The study team used the load resistance factor rating (LRFR) method (AASHTO 2011, 2013) in conformance with the latest design/analysis methodology. The study team obtained ABrR bridge models proof-tested using the LRFR method from the Federal Highway Administration (FHWA, NCHRP Rpt 700, 2012) and from the States. The only exceptions were for through-trusses and girder-floor-beam bridges, for which there is not yet any LRFR capability in ABrR. The load factor rating (LFR) method was employed for those few bridges. The bridge models were selected for analysis in proportion to the number of bridges in the NBI by bridge type on the subject highway networks. The bridges were further screened to assure that they were representative in terms of age, condition, and span length. The results of the analysis were recorded for maximum moment and shear, and the rating factors (RF) for the alternative truck configurations were compared to (i.e., normalized relative to) the 80,000 lb. GVW control vehicles. In physics, moment is a combination of a physical quantity and a distance. Moments are usually defined with respect to a fixed reference point or axis; they deal with physical quantities as measured at some distance from that reference point or axis. For example, a moment of force is the product of a force and its distance from an axis, which causes rotation about that axis. In principle, any physical quantity can be combined with a distance to produce a moment; commonly used quantities include forces, masses, and electric charge distributions. A shear stress, denoted  $\tau$  (Greek: tau), is defined as the component of stress coplanar with a material cross section. Shear stress arises from the force vector component parallel to the cross section. Normal stress, on the other hand, arises from the force vector component perpendicular to the material cross section on which it acts.

This is the basis of a statistical assessment of the increase in the gross number of the bridges that would have structural/posting issues potentially requiring strengthening or replacement as a result of the alternative truck configurations. From this assessment, the one-time costs resulting from structural and posting related issues were derived. These one-time costs could pertain to either superstructure strengthening or superstructure replacement triggered by the need to

increase live load capacity. The choice of strengthening versus replacement would depend on superstructure type and whichever is the more economical alternative.

With respect to the structural analysis element (see **Chapter 3**), the study team assessed how many bridges of the bridges selected from the NBI for this study had posting issues and would potentially require either strengthening or replacement based on the derived rating factors for each alternative truck configuration in each scenario. A threshold Rating Factor (RF) value of 1.0 establishes a potential need for bridge strengthening or replacement.

With respect to the fatigue element, the study team investigated load-induced steel fatigue as a result of truck loadings. Four steel bridges of various span lengths, configurations (simply supported and continuous), and fatigue category details were investigated using a comparative analysis approach.

As noted above, the USDOT study team was not able to identify a bridge deck impact model suited for estimating the type of bridge deck wear assessed under this study. While attempts were made to produce a modeling protocol that might be useful for the purposes of conducting a national analysis as undertaken in this study, a modeling approach of suitable scale and based on generally accepted procedures and sound engineering principles was not available, and this aspect of the analysis was not included in the set of results otherwise produced for the study.

Finally, estimation of the cost responsibility assigned to each of the Scenario vehicles was conducted as part of the study, albeit not as thoroughly as originally intended. As noted above, the structural analysis that was conducted fully evaluated the impacts of the scenario vehicles and provides estimates of one-time costs to substantially rehabilitate or replace bridges unable to accommodate each of the alternative configuration vehicles. The evaluation of fatigue attributed to the various truck configurations was also completed and is included in the study. Results produced in these two areas are presented by Scenario with their associated implications on cost. For the purposes of isolating one-time costs, the study assumed a complete end state of each alternative configuration for 2011 freight volumes, where all bridges on the highway systems needing substantial rehabilitation or replacement would be replaced instantaneously. If any of these alternative configurations were to be introduced in the United States, infrastructure owners would make the upgrades gradually over the course of a number of years and likely prioritize necessary bridge rehabilitations or replacements on the system.

### ***Assumptions and Limitations***

The USDOT study team performed this bridge structural comparative analysis based on the following assumptions:

- Annual bridge capital costs are based on 2011 (base year) cost summaries from the USDOT's Fiscal Management Information System (FMIS) and include both the State and Federal shares.
- Bridge damage costs are equated to the total related repair and replacement project costs (inclusive of design, construction inspection, etc.).

- Maximum legal weights for each truck class are used for structural analysis and for fatigue analysis.

Similarly, the following limitations further define the parameters of this study:

- Costs derived for both the one-time structural related issues are independently investigated for each scenario. The costs for multiple scenarios are by the nature of the analysis not additive.
- The reported one-time structural related costs represent an extreme upper bound.
- Distortion induced fatigue in steel members is not included in the study. I-beams, hollow channels and other bridge superstructure elements made of steel are considered steel members.
- While an extensive literature search was conducted and expounded upon, study schedule and time constraints only supported the detailed analysis of representative bridges.
- Load and Resistance Factor Rating (LRFR) capability was not available in AASHTO’s ABrR software for the structural analysis of trusses and girder-floor-beam bridges (consequently, LFR was used for those bridge types).
- Outputs from the modal shift modeling effort produced data that did not distinguish between intra-modal (truck-to-truck) and inter-modal (between modes) shifts.

**Summary of Results**

Based on the derived rating factors for each of the alternative truck configurations in each scenario, an assessment was made on the number of bridges that had posting issues and would potentially require either strengthening or replacement. A threshold Rating Factor (RF) value of 1.0 establishes a potential need for bridge strengthening or replacement. **Table ES2** shows both the projected percentages and the number of bridges that would have posting issues for each scenario assessed.

**Table ES-2: Projected Number of Bridges with Posting Issues  
for the Entire NHS Inventory**

NUMBER OF BRIDGES IN THE NBI		LOAD RATING RESULTS					PROJECTED NUMBER OF BRIDGES W/ POSTING ISSUES FOR ENTIRE INVENTORY	
# of IS Bridges in the NBI	# of Other NHS Bridges in the NBI	# of IS Bridges Rated	# of Other NHS Bridges Rated	Vehicle Configuration	IS Bridges Rated w/ RF < 1.0 (percent)	Other NHS Bridges Rated w/ RF < 1.0 (percent)	# of IS Bridges w/ Posting Issues	# of Other NHS Bridges w/ Posting Issues
45417	43528	153	337	Scenario 1	3.3%	5.0%	1485	2194
				Scenario 2	3.3%	7.7%	1485	3360
				Scenario 3	4.6%	9.5%	2080	4135
				Scenario 4	2.6%	3.0%	1185	1293
				Scenario 5	2.0%	0.9%	890	387
				Scenario 6	6.5%	5.6%	2970	2455



Based on these findings, **Table ES-3** contains a summary of what is considered the upper bound of the projected one-time costs to strengthen or replace these bridges for each alternative truck configuration scenario.

The findings generally indicated that relatively heavier axle loads and axle groupings tend to negatively affect fatigue life when compared to the control vehicles. However, any overall reduction in bridge fatigue life depends on the number of relatively heavier trucks that are in the traffic stream. In general, fatigue-related costs in steel bridges are small compared to the total bridge program cost.

Bridge deck repair and replacement costs and bridge deck preservation and preventative maintenance were initially investigated together since the topics are intimately linked.

Bridge Deck limit states include the ultimate deck strength limit and the deck durability service limit. AASHTO design criteria (AASHTO 2002, 2011) provide bridge decks with adequate strength to carry the potentially heavier alternative truck configuration axle loads; however cyclic axle loadings diminish deck service life or durability.

As noted above, the impact on the annual cost of maintaining bridge decks was not completed due to the lack of a generally accepted modeling regiment. A complete estimate of cost responsibility associated with each of the Scenario vehicles could not be completed for this reason.

**Table ES-3: Projected One-time Bridge Costs for Each Alternative Truck Configuration Scenario (\$ billions)**

	<b>Projected One Time Strengthening or Replacement Costs</b>
<b>Scenario 1</b>	\$0.4 B
<b>Scenario 2</b>	\$1.1 B
<b>Scenario 3</b>	\$2.2 B
<b>Scenario 4</b>	\$1.1 B
<b>Scenario 5</b>	\$0.7 B
<b>Scenario 6</b>	\$5.4 B

Note: Costs are in 2011 dollars.

**TABLE OF CONTENTS**

**Chapter 1 – Bridge Task Desk Scan And Research..... 1**

    1.1 Introduction..... 1

    1.2 Structural Analysis Methodology ..... 2

    1.3 Cost Allocation Methodology..... 4

**Chapter 2 – Structural Analysis and Bridge Posting Assessment..... 13**

    2.1 Overview ..... 13

    2.2 Bridge Inventory Used In the Structural Analysis ..... 15

    2.3 Load Rating Results For All Bridges..... 24

    2.4 Posting Analysis..... 36

    2.5 Load Effects Based On Span Lengths ..... 49

    2.6 Summary Findings: Load Effects by Span Length and Scenario ..... 56

**Chapter 3 – One-Time Bridge Rehabilitation/Replacement Costs ..... 58**

**Chapter 4 – Scenario Cost Summaries ..... 63**

    Observations ..... 63

**Chapter 5 –Assessment of Bridge Fatigue and Investigation into Bridge Deck Wear..... 65**

    5.1 Fatigue-related Effects ..... 65

    5.2 Bridge Deck Deterioration, Service Life, and Preventative Maintenance..... 76

    References..... 89

**Appendix A – Revised Desk Scan Report..... 94**

**Appendix B – Bridge Project Plan/Schedule..... 169**

**Appendix C – Load Ratings and Analysis ..... 183**

**LIST OF FIGURES**

Figure 1: Distribution of All Bridges by Bridge Type..... 18

Figure 2: Distribution of Interstate Bridges by Bridge Type..... 18

Figure 3: Distribution of other bridges on the NHS by bridge type. .... 19

Figure 4: Distribution of All Bridges by Span Length ..... 20

Figure 5: Distribution of Interstate Bridges by Span Length..... 20

Figure 6: Distribution of Other Bridges on the NHS by Span Length..... 21

Figure 7: Distribution of All Bridges by Built Year ..... 22

Figure 8: Distribution of Interstate Bridges by Built Year ..... 23

Figure 9: Distribution of Other Bridges on the NHS by Built Year ..... 23

Figure 10: Comparison of Average Flexural Rating Factors for Different Truck Types ..... 25

Figure 11: Comparison of Average Shear Rating Factors for Different Truck Types ..... 26

Figure 12: Comparison of Number of Bridges that Require Posting Due to Flexure for  
Different Truck Types..... 26

Figure 13: Comparison of Number of Bridges that Require Posting Due to Shear for  
Different Truck Types..... 27

Figure 14: Comparison of Flexural Rating Factors for All Bridges (Compared with 3-S2) ..... 28

Figure 15: Comparison of Flexural Rating Factors for All Bridges (Compared with 2-S1-2)..... 28

Figure 16: Comparison of Shear Rating Factors for All Bridges (Compared with 3-S2) ..... 29

Figure 17: Comparison of Shear Rating Factors for All Bridges (Compared with 2-S1-2)..... 29

Figure 18: Cumulative Distribution of Flexural Rating Factors of All Bridges  
(3-S2, Scenarios 1-3) ..... 30

Figure 19: Cumulative Distribution of Flexural Rating Factors of All Bridges  
(2-S1-2, Scenarios 4-6) ..... 31

Figure 20: Cumulative Distribution of Shear Rating Factors of All Bridges  
(3-S2, Scenarios 1-3) ..... 31

Figure 21: Cumulative Distribution of Shear Rating Factors of All Bridges  
(2-S1-2, Scenarios 4-6) ..... 32

Figure 22: Distribution of Normalized Flexural Rating Factors for All Bridges  
(3-S2, Scenario 1, 2 and 3)..... 34

Figure 23: Distribution of Normalized Flexural Rating Factors for All Bridges  
(2-S1-2, Scenario 4, 5 and 6) ..... 34

Figure 24: Distribution of Normalized Shear Rating Factors for All Bridges  
(3-S2, Scenario 1, 2 And 3) ..... 35

Figure 25: Distribution of Normalized Shear Rating Factors for All Bridges  
(2-S1-2, Scenario 4, 5 and 6) ..... 35

Figure 26: Normalized Flexural Load Effects for Simple Spans (3-S2, Scenario 1, 2 and 3)..... 53

Figure 27: Normalized Flexural Load Effects for Simple Spans (2-S1-2, Scenario 4, 5 and 6) . 53

Figure 28: Normalized Shear Load Effects for Simple Spans (3-S2, Scenario 1, 2 and 3)..... 54

Figure 29: Normalized Shear Load Effects for Simple Spans (2-S1-2, Scenario 4, 5 and 6)..... 54

Figure 30: Normalized Flexural Load Effects for Continuous Spans (3-S2, Scenario 1, 2 and 3).....	55
Figure 31: Normalized Flexural Load Effects for Continuous Spans (2-S1-2, Scenario 4, 5 and 6) .....	55
Figure 32: Region of Concern for Fatigue in Highway Bridges.....	67
Figure 33: Control Vehicles and Alternative Truck Configurations in Each of the Six Scenarios.....	71
Figure 34: STAA 53' (max) Semitrailer Single Control Vehicle .....	77
Figure 35: STAA 28' Double Control Vehicle.....	78
Figure 36: Photo of Newburgh-Beacon Bridge (I-84) Eastbound .....	85
Figure 37: Bridge Cost Allocation Work Flow.....	176
Figure STR-1: Comparison of average flexural rating factors for different truck types. ....	189
Figure STR-2: Comparison of average shear rating factors for different truck types. ....	189
Figure STR-3: Comparison of flexural rating factors for all bridges (compared with 3-S2) .....	190
Figure STR-4: Comparison of flexural rating factors for all bridges (compared with 2-S1-2) ..	190
Figure STR-5: Comparison of flexural rating factors for IHS bridges (compared with 3-S2)...	191
Figure STR-6: Comparison of flexural rating factors for IHS bridges (compared with 2-S1-2) .....	191
Figure STR-7: Comparison of flexural rating factors for other bridges on the NHS (compared with 3-S2) .....	192
Figure STR-8: Comparison of flexural rating factors for other bridges on the NHS (compared with 2-S1-2) .....	192
Figure STR-9: Comparison of shear rating factors for all bridges (compared with 3-S2) .....	193
Figure STR-10: Comparison of shear rating factors for all bridges (compared with 2-S1-2)....	193
Figure STR-11: Comparison of shear rating factors for IHS bridges (compared with 3-S2).....	194
Figure STR-12: Comparison of shear rating factors for IHS bridges (compared with 2-S1-2) .	194
Figure STR-13: Comparison of shear rating factors for other bridges on the NHS (compared with 3-S2) .....	195
Figure STR-14: Comparison of shear rating factors for other bridges on the NHS (compared with 2-S1-2).....	195
Figure STR-15: Cumulative distribution of flexural rating factors of all bridges (3-S2, Scenarios 1 - 3) .....	196
Figure STR-16: Cumulative distribution of flexural rating factors of all bridges (2-S1-2, Scenarios 4 - 6) .....	196
Figure STR-17: Cumulative distribution of shear rating factors of all bridges (3-S2, Scenarios 1 - 3) .....	197
Figure STR-18: Cumulative distribution of shear rating factors of all bridges (2-S1-2, Scenarios 4 - 6) .....	197
Figure STR-19: Cumulative distribution of flexural rating factors of IHS bridges (3-S2, Scenarios 1 - 3) .....	198

Figure STR-20: Cumulative distribution of flexural rating factors of IHS bridges  
(2-S1-2, Scenarios 4 - 6) ..... 198

Figure STR-21: Cumulative distribution of shear rating factors of IHS bridges  
(3-S2, Scenarios 1 - 3) ..... 199

Figure STR-22: Cumulative distribution of shear rating factors of IHS bridges  
(2-S1-2, Scenarios 4 - 6) ..... 199

Figure STR-23: Cumulative distribution of flexural rating factors of other bridges on the  
NHS (3-S2, Scenarios 1-3) ..... 200

Figure STR-24: Cumulative distribution of flexural rating factors of other bridges on the  
NHS (2-S1-2, Scenarios 4 - 6) ..... 200

Figure STR-25: Cumulative distribution of flexural rating factors of other bridges on the  
NHS (3-S2, Scenarios 1 - 3) ..... 201

Figure STR-26: Cumulative distribution of flexural rating factors of other bridges on the  
NHS (2-S1-2, Scenarios 4 - 6) ..... 201

Figure STR-27: Distribution of normalized flexural rating factors for all bridges  
(3-S2, Scenario #1, #2 and #3)..... 202

Figure STR-28: Distribution of normalized flexural rating factors for all bridges  
(2-S1-2, Scenario #4, #5 and #6) ..... 202

Figure STR-29: Distribution of normalized shear rating factors for all bridges  
(3-S2, Scenario #1, #2 and #3)..... 203

Figure STR-30: Distribution of normalized shear rating factors for all bridges  
(2-S1-2, Scenario #4, #5 and #6) ..... 203

Figure STR-31: Distribution of normalized flexural rating factors for IHS Bridges  
(3-S2, Scenario #1, #2 and #3)..... 204

Figure STR-32: Distribution of normalized flexural rating factors for IHS bridges  
(2-S1-2, Scenario #4, #5 and #6). ..... 204

Figure STR-33: Distribution of normalized shear rating factors for IHS Bridges  
(3-S2, Scenario #1, #2 and #3)..... 205

Figure STR-34: Distribution of normalized shear rating factors for IHS bridges  
(2-S1-2, Scenario #4, #5 and #6) ..... 205

Figure STR-35: Distribution of normalized flexural rating factors for other bridges on the  
NHS (3-S2, Scenario #1, #2 and #3)..... 206

Figure STR-36: Distribution of normalized flexural rating factors for other bridges on the  
NHS (2-S1-2, Scenario #4, #5 and #6) ..... 206

Figure STR-37: Distribution of normalized shear rating factors for other bridges on the  
NHS (3-S2, Scenario #1, #2 and #3)..... 207

Figure STR-38: Distribution of normalized shear rating factors for other bridges on the  
NHS (2-S1-2, Scenario #4, #5 and #6) ..... 207

**LIST OF TABLES**

Table 1: Breakdown of the Bridges in the Sample Database.....	13
Table 2: Projected Number of Posted Bridges for the Entire NHS Inventory.....	14
Table 3: Breakdown of the Bridges on the NHS .....	15
Table 4: Breakdown of the Bridges in the Sample Database.....	17
Table 5: Breakdown of the Sample Database by State.....	17
Table 6: Distribution of the Bridges by Span Length.....	19
Table 7: Distribution of the Bridges by Year Built.....	22
Table 8: Flexural Rating Result Statistics (GFB and Truss Bridges Not Included).....	24
Table 9: Shear Rating Result Statistics (GFB and Truss Bridges Not Included).....	25
Table 10: Normalized Flexural Load Rating Results .....	33
Table 11: Normalized Shear Load Rating Results.....	33
Table 12: Projected Number of Posted Bridges for the Entire NHS Inventory.....	37
Table 13: Bridges with RF < 1.0 Sorted by Bridge Type.....	38
Table 14: Posting Projections .....	41
Table 15: Bridges with RF < 1.0 Sorted by Span Length.....	44
Table 16: Bridges with RF < 1.0 Sorted by Year Built .....	47
Table 17: Positive Moment Load Effects for Simple Spans.....	50
Table 18: Shear Load Effects for Simple Spans.....	50
Table 19: Negative Moment Load Effects for Continuous Spans.....	51
Table 20: Normalized Positive Moment Load Effects for Simple Spans\.....	51
Table 21: Normalized Shear Load Effects for Simple Spans.....	52
Table 22: Normalized Negative Moment Load Effects for Continuous Spans.....	52
Table 23: Cost of One Time Bridge Rehabilitations, per Bridge .....	59
Table 24: Projected Total Rehabilitation Costs for Interstate Bridges.....	61
Table 25: Projected Total Rehabilitation Costs for Other Bridges on the NHS.....	61
Table 26: Projected Δcosts for Interstate Bridges and Other Bridges on the NHS.....	62
Table 27: Scenario 1-6 Summary.....	63
Table 28: Bridge #1 Results.....	72
Table 29: Bridge #2 Results.....	73
Table 30: Bridge #3 Results.....	74
Table 31: Bridge #4 Results.....	75
Table 32: Deck Repair, Rehabilitation and Replacement Unit Costs.....	88
Table 33: Partial Bridge Type Matrix.....	171
Table 34: Bridge Type Compilation.....	172
Table 35: WIM Observation Data with Summation of Relative Damage Shares (RDS).....	175
Table 36: Hypothetical Damage Distribution Profile Prior to and After Modal Shift.....	175
Table STR-1: Flexural Rating Result Statistics (GFB and Truss Bridges Not Included).....	188
Table STR-2: Shear Rating Result Statistics (GFB and Truss Bridges Not Included).....	188
Table STR-3: Flexural Rating Result Statistics for Reinforced Concrete Slabs.....	208

Table STR-4: Shear Rating Result Statistics for Reinforced Concrete Slabs.....	208
Table STR-5: Flexural Rating Result Statistics for Prestressed Concrete Beam/Girders, Simple Spans.....	209
Table STR-6: Shear Rating Result Statistics for Prestressed Concrete Beam/Girders, Simple Spans.....	209
Table STR-7: Flexural Rating Result Statistics for Prestressed Concrete Beam/Girders, Continuous Spans.....	210
Table STR-8: Shear Rating Result Statistics for Prestressed Concrete Beam/Girders, Continuous Spans.....	210
Table STR-9: Flexural Rating Result Statistics for Steel Beam/Girder, Simple Span (L < 100 ft.).....	211
Table STR-10: Shear Rating Result Statistics for Steel Beam/Girder, Simple Span (L < 100 ft.).....	211
Table STR-11: Flexural Rating Result Statistics for Steel Beam/Girder, Simple Span (L > 100 ft.).....	212
Table STR-12: Shear Rating Result Statistics for Steel Beam/Girder, Simple Span (L > 100 ft.).....	212
Table STR-13: Flexural Rating Result Statistics for Steel Beam/Girder, Continuous Spans (L < 100 ft.).....	213
Table STR-14: Shear Rating Result Statistics for Steel Beam/Girder, Continuous Spans (L < 100 ft.).....	213
Table STR-15: Flexural Rating Result Statistics for Steel Beam/Girder, Continuous Spans (L > 100 ft.).....	214
Table STR-16: Shear Rating Result Statistics for Steel Beam/Girder, Continuous Spans (L > 100 ft.).....	214
Table STR-17: LFR Rating Factors for Girder Floorbeam Systems.....	215
Table STR-18: Flexural Rating Result Statistics for Reinforced Concrete Tee Beams.....	215
Table STR-19: Shear Rating Result Statistics for Reinforced Concrete Tee Beams.....	216
Table STR-20: Flexural Rating Result Statistics for Box Beams.....	216
Table STR-21: Shear Rating Result Statistics for Box Beams.....	217
Table STR-22: LFR Rating Factors for <i>Through Trusses</i> .....	217
Table STR-23: Normalized Flexural Rating Result Statistics for Reinforced Concrete Slabs...	218
Table STR-24: Normalized Shear Rating Result Statistics for Reinforced Concrete Slabs.....	218
Table STR-25: Normalized Flexural Rating Result Statistics for Prestressed Concrete Beam/Girders, Simple Spans.....	219
Table STR-26: Normalized Shear Rating Result Statistics for Prestressed Concrete Beam/Girders, Simple Spans.....	219
Table STR-27: Normalized Flexural Rating Result Statistics for Prestressed Concrete Beam/Girders, Continuous Spans.....	220

Table STR-28: Normalized Shear Rating Result Statistics for Prestressed Concrete Beam/Girders, Continuous Spans .....	220
Table STR-29: Normalized Flexural Rating Result Statistics for Steel Beam/Girder, Simple Span (L < 100 ft.) .....	221
Table STR-30: Normalized Shear Rating Result Statistics for Steel Beam/Girder, Simple Span (L < 100 ft.) .....	221
Table STR-31: Normalized Flexural Rating Result Statistics for Steel Beam/Girder, Simple Span (L > 100 ft.) .....	222
Table STR-32: Normalized Shear Rating Result Statistics for Steel Beam/Girder, Simple Span (L > 100 ft.) .....	222
Table STR-33: Normalized Flexural Rating Result Statistics for Steel Beam/Girder, Continuous Spans (L < 100 ft.).....	223
Table STR-34: Normalized Shear Rating Result Statistics for Steel Beam/Girder, Continuous Spans (L < 100 ft.).....	223
Table STR-35: Normalized Flexural Rating Result Statistics for Steel Beam/Girder, Continuous Spans (L > 100 ft.).....	224
Table STR-36: Normalized Shear Rating Result Statistics for Steel Beam/Girder, Continuous Spans (L > 100 ft.).....	224
Table STR-37: Normalized LFR Rating Factors for Girder Floorbeam Systems .....	225
Table STR-38: Normalized Flexural Rating Result Statistics for Reinforced Concrete Tee Beams.....	225
Table STR-39: Normalized Shear Rating Result Statistics for Reinforced Concrete Tee Beams.....	226
Table STR-40: Normalized Flexural Rating Result Statistics for Box Beams.....	226
Table STR-41: Normalized Shear Rating Result Statistics for Box Beams .....	227
Table STR-42: Normalized LFR Rating Factors for <i>Through Trusses</i> .....	227
Table STR-43: Bridges with RF < 1.0 Sorted by Bridge Type .....	228
Table STR-44: Bridges with RF < 1.0 Sorted by Span Length .....	231
Table STR-45: Bridges with RF < 1.0 Sorted by Year Built.....	234
Table STR-46: Posting Projections.....	237



### LIST OF ACRONYMS

<b>Acronym</b>	<b>Definition</b>
AASHTO	American Association of State Highway and Transportation Officials
ABrR	<i>AASHTOWare Bridge Rating</i> ®
ADTT	average daily truck traffic
AGM	average gross mass
ASR	allowable stress rating
CAFT	constant-amplitude fatigue threshold
CTSW	Comprehensive Truck Size and Weight Limits Study
ESAL	equivalent single axle load
FHWA	Federal Highway Administration
GCW	gross combined weight
GVW	gross vehicle weight
LCV	longer combination vehicles
LTL	less than truckload
LFR	load factor rating
LRFR	load resistance factor rating
LRFD	load and resistance factor design
LTBP	Long Term Bridge Performance
NBI	National Bridge Inventory
NBMD	National Bridge Management Database
NHS	National Highway System
NHTSA	National Highway Traffic Safety Administration
PCE	passenger car equivalents
PCU	passenger car units
RC	reinforced concrete
RF	rating factor
STAA	Surface Transportation Assistance Act
TMG	Traffic Monitoring Guidelines
USDOT	US Department of Transportation
VMT	vehicle miles traveled
WIM	weigh-in-motion

## CHAPTER 1 - BRIDGE TASK DESK SCAN AND RESEARCH

### **1.1 Introduction**

The bridge desk scan was initially conducted to find relevant information and data with respect to the bridge structural analysis, cost responsibility, and fatigue studies. It was then expanded to address the general issues of the bridge deterioration mechanisms and bridge deck deterioration modeling.

With respect to the bridge structural analysis and the load rating subtask, the most relevant guiding documents are a series of American Association of State Highway and Transportation Officials (AASHTO) manuals – the *Standard Specifications for Highway Bridges*, 17<sup>th</sup> Edition, 2002; the *Load and Resistance Factor Design (LRFD) Bridge Design Specifications*; and the *Manual for Bridge Evaluation*, 2<sup>nd</sup> Edition 2013; which covers both bridge inspection requirements and LRFR load rating procedures.

The prevailing sense of the research was that the subject area of the bridge structural analysis methods are proscribed and regulated by AASHTO and the statutes of the governing State transportation agencies.

With respect to the Bridge Cost Responsibility work, there has not been one accepted and proven methodology for allocating bridge damage cost responsibility.

The study team reviewed numerous State-sponsored studies as well as those conducted in other countries. An unpublished 2010 District Wide Truck Safety Study for Washington DC was evaluated for applicability to the work being undertaken in this part of the study. Concepts and information from the *NCHRP Report 495, Effect of Truck Weight on Bridge Network Costs* (2004) were also considered for use in developing a methodology to estimate bridge costs and needs. Numerous permutations of the Federal/ Incremental Method (FHWA HCAS Guidelines, 2000) have been applied in various ways, and load-based allocations continue to be employed in part or in combination with other approaches. No method has been successfully applied on the scale of a U.S. Federal study. See Section 1.3 below for a review of this history.

Following a further review of this work by FHWA bridge program experts, the study team decided not to include this work in the Study since it does not represent a generally accepted methodology or approach that is widely used and understood by the larger bridge community.

The FHWA is engaged in the development process for the Long Term Bridge Performance (LTBP) program, which is intended to provide a more detailed and timely picture of bridge health, improve knowledge of bridge performance, and lead to better bridge management tools. The National Bridge Management Database (NBMD), currently under development, will be a resource for the LTBP to better understand the impact of changing truck configurations on bridge performance.

## **1.2 Structural Analysis Methodology**

The AASHTO *LRFD Bridge Design Specifications* (LRFD Specifications) introduced a limit state design philosophy, based on structural reliability methods, to achieve a more uniform level of safety (reliability) in bridge design. Limit state design (LSD), also known as load and resistance factor design (LRFD), refers to a design method used in structural engineering. A limit state is a condition of a structure beyond which it no longer fulfills the relevant design criteria. The condition may refer to a degree of loading or other actions on the structure, while the criteria refer to structural integrity, fitness for use, durability or other design requirements. A structure designed by LSD is proportioned to sustain all actions likely to occur during its design life, and to remain fit for use, with an appropriate level of reliability for each limit state. A National Cooperative Highway Research Program project (NCHRP Project No. 12-46, 2000) was initiated in March 1997 to develop a new AASHTO *Load and Resistance Factor Rating Manual for Highway Bridges*. The objective of the project was to develop a manual with supporting commentary and illustrative examples for the evaluation of highway bridges by the load and resistance factor method. The final draft of the *Manual for Condition Evaluation and Load and Resistance Factor Rating of Highway Bridges* (LRFR Manual) was completed in March 2000 and was adopted as a Guide Manual by the AASHTO Subcommittee on Bridges and Structures at the 2002 AASHTO Bridge Conference. In the following years, the LRFR Manual was revised, expanded, and renamed as the AASHTO *Manual for Bridge Evaluation* (AASHTO MBE, 2013). At the time of this writing, the AASHTO MBE, 2<sup>nd</sup> Edition with 2014 Interim Revisions is the most current edition of the manual. Load and resistance factor rating (LRFR) and load factor rating (LFR) are the current national standards for load ratings. Unlike LFR, in LRFR, only a single load rating is derived for legal and permit loads; this load rating reflects the safe load capacity of the bridge for a particular truck.

Compared to the load factor rating (LFR) and the allowable stress rating (ASR) methodologies, the LRFR methodology provides a systematic and more comprehensive approach to bridge load rating that is reliability-based and provides a more realistic assessment of the safe load capacity of existing bridges. Unlike past load rating methods (ASR and LFR), LRFR provides uniform reliability in load ratings and postings across varying span lengths and bridge span configurations. The LRFR methodology adopts a tiered approach to load rating for design, legal, and permit loads that provides an efficient approach to bridge evaluation and the flexibility to perform more detailed evaluations when necessary to avoid load restrictions or bridge strengthening. Acceptable minimum reliability indices for evaluation have been determined by calibrating to past load rating practice. An appropriate increased reliability index is maintained for deteriorated and non-redundant bridges by using condition and system factors in the load rating equation. The influence of truck traffic volume, characterized by Average Daily Truck Traffic (ADTT), on the probability of high-load events and simultaneous truck crossings were considered in the calibration process and incorporated in legal and permit live load factors. Detailed procedures for bridge fatigue evaluation and load testing consistent with the LRFD philosophy have been included in the methodology to encourage more widespread use of these technologies.

The load rating is generally expressed as a rating factor for a particular live load model. The following general expression is used in determining the load rating of each component and connection subjected to a single force effect (i.e. axial force, flexure or shear):

$$RF = \frac{C - (\gamma_{DC})(DC) - (\gamma_{DW})(DW) \pm (\gamma_P)(P)}{(\gamma_{LL})(LL)}$$

For the Strength Limit States:

$$C = \varphi_c \varphi_s \varphi R_n$$

where:

RF = Rating factor

C = Capacity

$\varphi_c$  = Condition factor

$\varphi_s$  = System factor

$\varphi$  = Resistance factor

$R_n$  = Nominal member resistance (as inspected)

DC = Dead load effect due to structural components and attachments

DW = Dead load effect due to wearing surface and utilities

P = Permanent loads other than dead loads

LL = Live load effect

IM = Dynamic load allowance

$\gamma_{DC}$  = LRFD load factor for structural components and attachments

$\gamma_{DW}$  = LRFD load factor for wearing surfaces and utilities

$\gamma_p$  = LRFD load factor for permanent loads other than dead loads

$\gamma_{LL}$  = Evaluation live load factor

A normalized rating factor can also be computed to make comparisons of rating results from two different live load models. The normalized rating factor is determined by dividing the rating factor computed for a live load model by the rating factor computed for a baseline vehicle.

Bridge posting involves a consideration of safety, economy, and the public interest. Statutory law governs the maximum weight of vehicles legally allowed on bridges without special overload permits. Weight limits are required for bridges that are found to be structurally inadequate. The National Bridge Inspection Standards (NBIS Section 23 of Code of Federal Regulation Part 650) require that every bridge be rated for its safe load-carrying capacity in accordance with the AASHTO (MBE, 2013). According to the NBIS:

*If it is determined under this rating procedure that the maximum legal load under State law exceeds the load permitted under the Operating Rating, the bridge must be posted in conformity with the AASHTO Manual or in accordance with the State law.*

Posting regulations, including the criteria for initiating a posting action, methodology for setting the allowable truck weight limit, and techniques for how the limits should be represented on highway signage vary widely among agencies. The NBIS provides limited guidance on

evaluating and posting weight limits on bridges. In this regard, State department of transportation (DOT) posting policies will usually take precedence.

A Rating Factor (RF) of 1.0 was set as the acceptance criteria when making load posting decisions or determining bridge improvement needs. The choice of load posting or strengthening versus replacement is mostly based on the available funding, importance of the structure, as well as the availability of alternate travel routes. The results of this study are based solely on analytical methods and do not consider State policies with regard to postings.

The data-driven study described in this report provides an objective comparison of posting impacts across the various jurisdictions and provides a uniform basis for decision making that is driven by bridge safety considerations. Being data-driven, this approach is entirely transparent and is applied consistently over the entire database. Additionally, the most current national standards for bridge load rating were used as the basis for posting evaluations to maximize reliability and confidence in the results.

### **1.3 Cost Allocation Methodology**

#### ***A Short History of Truck Size and Weight Studies***

Over the years there has been a large volume of studies and research related to truck size and weight as well as attempts by agencies, university academics, and consultants to determine means and methods to assign cost responsibility for infrastructure investments to a diverse set of roadway users. The breadth of these studies, diverse interests, and funding levels by the supporting agencies make them a challenge to conduct. A lack of consensus on methodologies and elements of study to be included has had contributed to inconsistency among the results and conclusions. Various studies were employed to answer fundamentally different questions. Another factor that has presented a further challenge is the data gap issue. Quality and quantity of viable information in the format desired are inconsistent. The data can be “mined” and “scrubbed” and often must be reconfigured to address the needs of a particular study. Given these challenges, it is still possible to identify the most applicable of the existing approaches and build on them.

#### ***Research***

Existing literature references that were found in an unpublished District of Columbia Department of Transportation report (the “District-wide Truck Safety Enforcement Plan,” May 2010) was used as a starting point to guide research in this area. The bibliographies found in this report pointed toward additional sources of information. In addition, various search engines were used to search the internet for other work available. The study team perused Web sites for domestic and foreign universities and transportation agencies to obtain more data and identify the information available in the academic community. Journals available through the American Society of Civil Engineers and the Knovel Online Library enabled access to archived or proprietary studies. A few other resources were identified as part of the research to develop Desk Scan references for the other technical areas included under the Study.

The result of these efforts was a comprehensive list of references with summary descriptions of each study and a commentary on its relevance to this study in the Bridge Task Desk Scan Document (**Appendix A**). As new and other relevant documents were identified during the course of completing the study, they have been added to the desk scan document.

The purpose and result of the literature search was to provide a starting point and a framework for the work required to complete this area of the study. The following sections provide a brief history of the most relevant documents found that pertain to the major topics and issues addressed in this bridge structure comparative analysis.

### ***Other Cost Methodologies***

The USDOT study team reviewed a number of different cost allocation methodologies. The most prevalent method used in the United States in the past decade (1997 – 2012) has been the “Federal Method,” as described in the 2003 *NCHRP Report 495– Effect of Truck Weight on Bridge Network Costs*, which was derived from the 1997 *FHWA Highway Cost Allocation Study*. Both of these documents are a refinement of the previous incremental methods developed in the 70s and 80s. The Federal Method has been developed for use by individual States and local highway network authorities and has not been adapted to any national or even regional studies. To implement the Federal Method on a national scale would require a level of detail not available in a consistent format in the National Bridge Inventory System (NBIS) and potentially not available at all. The required information includes detailed structural data for each bridge, bridge-specific condition data, current detailed cost and expenditure data, and weigh-in-motion (WIM) data specifically applicable to bridges. It should be noted that States have different policies and procedures as they relate to bridge posting, rehabilitation, and preservation. It would be extremely difficult to reflect all of those policy differences in a national study.

States have used the Federal Method in modified formats to allocate bridge costs. They have also used varied allocators (vehicle miles traveled (VMT), passenger car equivalent (PCE), passenger car units (PCU), average gross mass (AGM) or equivalent single axle load (ESAL)) for different bridge elements and for various other bridge-related costs. **It should be stressed that there has been no uniformity or consensus in regard to what should be included in a “bridge allocation study.”** Perhaps most importantly, States have designed the methodologies used in those prior studies to answer different questions. As noted above, the Federal Method cannot generate cost allocation at the level of detail envisioned under this current Study, or with a similar degree of transparency as one would hope to have for a study on a national scale. However, some aspects of the Federal Method, as set forth in NCHRP Report 495 (2003), can augment the application of any approach developed in the future.

Two reports chronicle the previous research related to cost responsibility in the United States. NCHRP Synthesis 378 (2008) provides a detailed history of U.S. cost allocation studies by State from the early 1940s through 2008. NCHRP 20-07 Task 303 (2011), “Directory of Significant Truck Size and Weight Research” is similar to the Synthesis 378 report but adds additional studies through 2011. Both documents provide summary conclusions drawn from the various studies regarding bridge costs and the effect of overweight trucks.

One notable study conducted in the United States was conducted in Vermont and resulted in the *Vermont Pilot Program Study* (2012). Under the Consolidated Appropriations Act of 2010 (PL 111-117), the State of Vermont raised truck size and weight limits on its Interstate System for a period of 1 year, beginning December 2009. The State allowed the six-axle trucks with a maximum of 99,000 lbs. GVW that were operating on Vermont's State Highway System to operate on the State's 280 miles of Interstate and 265 bridges. The Pilot Study Team investigated the effects of these higher weight trucks on bridge safety (structural demands) and durability (service life). The structural demands were assessed by conducting load rating analysis of a select number (about 10 percent) of the most vulnerable bridges. The Vermont study team evaluated the service lives of the bridges using a fatigue limit state. Twenty-five bridges (23 steel and 2 concrete) were selected, which represented the mix of bridge types, age, condition, lengths and material on the Vermont Interstate Highway System. According to the study, "The fatigue limit states... are based on the probabilities of failure on the member resistance. Estimating the remaining fatigue life with this limit state can provide a measure of the loss of service life. Since the majority of the bridges are steel, the fatigue limit states can be used to estimate the effects of increased gross vehicle weight (GVW) on service life."

The method involved estimating the fatigue lives of the 23 steel bridges for a baseline control loading with trucks in the existing fleet and then comparing it to the fleet of trucks (including the 99,000 lb. pilot study truck) operating during the pilot study year (December 2009 to December 2010). WIM and VMT data were used to determine the mix of trucks prior to 2009 and the mix during the pilot study year. AASHTO Category C fatigue details (such as shear studs, diaphragm connection plates, and stiffeners) were used. The Category C welds are widely used on steel bridges and the Vermont study team assumed that these common fatigue details would occur at the points of maximum stress. The measure of the fatigue life was assumed to be a broad indicator and "meaningful" measure of the impact of the 99,000 lb. truck on the bridge superstructure service life. The results indicated that 19 of the 23 steel bridges had an infinite fatigue life and would not be affected by the introduction of the 99-Kip<sup>1</sup> truck. The remaining 4 of the 23 bridges had a fatigue life that exceeded the 75-year design life of the bridges. Notably, a similar study of longer duration with a calibration of the limit state to the recognized service life of the bridges might yield another cost allocation approach. It is important to note that this pilot study may not be applicable to other States' bridges because Vermont has employed a design standard for its bridges that is based on use by heavier trucks than those authorized under the STAA.

Methodologies used in Europe and Australia were also reviewed. The European Union (E.U.) Cost Allocation of Transport Infrastructure (CATRIN, 2008) synthesis document of 2008 is a summary of methods of cost allocations used in the transportation industry (including roadways, railway, air transport and maritime) in Europe. Countries submitting studies included Austria, the UK, Belgium, Denmark, Finland, Germany, Poland, the Netherlands, Sweden and Switzerland. The methodologies these countries use to assess the allocation of roadway costs (including bridges) range from an econometric or "top-down" approach as well as an engineering or "bottom-up" approach. What is clear from this document is that there is a huge disparity of approaches between these countries due to data availability, cost categories, etc. In the end the

---

<sup>1</sup> Gross vehicle weight and axle loads are expressed in units of 1000 lbs., or "kips"

document does not sum up the cost responsibilities from each country, but rather summarizes the approaches used by each in a tabular format. So, all that can be surmised from this tabular matrix is that in some cases load-based allocators were used for highway cost allocation, including for bridges (either directly or in-directly). The Netherlands and Switzerland used them on their roadways and then broke out bridges as a percentage of overall costs. In Finland they used bridges directly in their cost allocation study. No new engineering methods were introduced; except for in Germany (The Maut Study) where researchers applied PCEs. Another observation is that the number of vehicle classes used in the cost responsibility procedures shows a great variance among the countries, ranging from 6 to as many as 27 (Netherlands), 30 (Switzerland), and 37 (United Kingdom) vehicle classes.

The Australian Method, as reported in the National Transport Commission's *Third Heavy Vehicle Road Pricing Determination Technical Report* (October 2005), uses a number of allocators to determine shares of vehicle cost responsibility. The study lumps all costs under "roadway" costs and then breaks out pavement and bridge costs. Bridge costs are compiled from the various regional transport industries and are categorized as Attributable and Non-attributable Costs. Original and new bridge construction costs are considered Non-attributable costs and are allocated by vehicle usage or vehicle kilometers traveled (VKT). These costs were estimated at 85 percent of all bridge costs. The Attributable Costs include preservation and maintenance, repairs and rehabilitation, and were estimated at 15 percent of all costs, with allocation based on PCUs. The Australian report acknowledged that there was a relationship between load-based allocators and bridge deterioration, but it stopped short of suggesting a method other than using PCUs. The report states "For other non-pavement expenditure (i.e., bridge) categories, there is little international consensus, and little information on which to judge to what extent alternative approaches might be applicable to Australia." In other words the Australian report does not endorse any other method for allocating bridge costs.

The Australian report, however, does present some apparent advantages. The Australian Bureau of Statistics (ABS) conducts a comprehensive, national Survey of Motor Vehicle Use (SMVU), which includes statistics on an annual basis on the number of vehicles, VKT, fuel consumption and AGM of all vehicles. It collects these data on 35 vehicle classifications (from motorcycles to passenger cars to busses and trucks) by roadway classification (main highway, arterial, local etc.) and on a State by State basis. Data collection in this manner would greatly facilitate any future study. A document similar to the Australian SMVU was found in the United States: the 1997 Vehicle Inventory Use Survey (VIUS, 1997, by the US Census Bureau) which was then published and analyzed in *The Analysis of the Vehicle Inventory and Use Survey for Trucks with Five-Axles or More* (2000). However, this document represents the last census data collection effort of this kind in the United States and was discontinued after 2000. It was collected by the FHWA Office of Transportation Policy Studies (2002).

In summary, the USDOT study team found the following:

- a) In the United States, no nationwide studies have been purely of bridge costs have been conducted to date that use a load-induced cost responsibility allocator.
- b) Internationally, there has been little consistency of data across states or other political boundaries.



- c) In part due to the lack of uniform data collection policies, there has also been little consistency in the methodologies used by the various agencies for assigning cost responsibilities across states (or provinces) and other political boundaries.
- d) These studies have used various metrics to help apportion, allocate or assign costs to the various truck classifications. The advantages and disadvantages of these metrics can be described as follows:
- Weigh-in-motion (WIM) Data: Data records include station description, traffic volume and count, speed data, vehicle classification based on FHWA's Traffic Monitoring Guidelines (TMG), and weight data.

Advantage: The data provides axle load estimates and counts – including the frequency and magnitude of axle weight measurements. Every State, through FHWA's Traffic Monitoring Program, monitors and reports vehicle volumes by type of vehicle, which makes the data current and readily available. Data is also reported to the FHWA in a standardized format.

Disadvantage: However, there are drawbacks to using WIM data to estimate system-level loading. The most critical challenge in using WIM data is system coverage. WIM sites are expensive to install and maintain, which affects the coverage of the system that WIM readings represent. As stated above, the initial raw data provides much of the basic information needed. However it cannot be used in its raw form since the data is highly fragmented—being collected at the vehicle axle level—and must be processed by scrubbing, aggregating, and weighting (by other parameters such as VMT) and then translated into usable format. In this final format much of the original detail may have been altered. For example, truck counts are collected at individual stations. However, these are only a snapshot of the data for a given day and hour of data collection. Different stations in the State may collect these data at different times, so as the data is aggregated, there will be gaps and overlaps. In order to compensate for these inconsistencies, the data are processed with subroutines to derive a sub-data set that represents the truck traffic stream in a given State.

- Vehicle miles traveled (VMT): VMT is an indicator of the travel levels on the roadway system by motor vehicle class. VMT is estimated for the given time period that is based upon traffic volume counts and roadway length. This metric is one of many allocator types used to estimate consumption of wearing surfaces on pavements and bridge decks.

Cons: The problem with using VMT as an allocator by itself is that it assumes equal consumption based on the relative miles traveled and does not account for the vehicle axle weight. For example, in applying VMT, it is assumed that a 3,500 pound car consumes the same stretch of pavement as an 80,000-lb., five-axle (3-S2) tractor semitrailer for the same distance traveled. Another problem with VMT is more specific to bridges: using VMT as a sole allocator presumes that bridges are distributed proportionally to the number of highway miles. However, bridge density (length of bridges and their count) per mile of highway varies geographically based on rural and urban environments, number of water crossings, and overpasses of intersecting roadways. Further, bridges are neither uniformly or proportionally

located in relation to highway miles (for example, a bridge is not located at a constant rate across the highway miles).

- Passenger car equivalents (PCE): PCE equates any of the TMG vehicle classes to a PCE or a passenger car unit (PCE or PCU) and is essentially the impact that a mode of transport has on traffic variables (such as headway, speed, density) compared to a single car. It is derived from taking a certain mixed traffic stream and heuristically or statistically converting it into a hypothetical passenger-car stream.

Disadvantage: Similar to VMTs, PCEs do not take into account axles loads. As an allocator it might be more useful to estimate delays and backups that may occur at a certain location (such as a bridge under construction). But the PCE is more of a capacity-based allocator and cannot provide a suitable estimate of the physical load impacts those trucks would have on the bridge itself.

- Equivalent single axle load (ESAL), load equivalency factor (LEF): The ESAL was originally derived in the 1940s after large trucks started to populate US highways and was introduced by AASHTO in a rather complex formula that was based on a standard truck axle weight of 18,000 pounds. The premise was that the standard 18,000-lb. axle induced a unit of damage on pavement. The complex formula was eventually reduced to a more simple ratio of actual axle load divided by the standard axle (i.e., 18,000 lbs.) raised to the 4<sup>th</sup> power, which is the LEF. It was later postulated that for different types of pavement (flexible or rigid) and substrate, the power of 3 may be more appropriate (PavementInteractive.org). Many transportation agencies in the United States and Europe (CATRIN, 2008) used variations of this formula to estimate impacts to bridges, and various power ratios were selected ranging from 2.0 to 4.0. Some agencies used the method directly to estimate pavement (highway) impacts and pulled out bridge costs simply as a percentage, while others applied the ESAL damage index directly to their bridges.

In time, new pavement damage models and methodologies were developed such as those found in AASHTO's Mechanistic-Empirical Pavement Design Guidelines (MEPDG). In spite of this, the ESAL/LEF methodology continues to be used by some State transportation agencies because it provides a method of incorporating axle loads and frequency of occurrence to estimate pavement and bridge damage. MEPDG modeling regiments continue to be developed and refined and are emerging as the preferred approach in estimating pavement impacts caused by various vehicles. The MEPDG is used in the *Volume II: Pavement Comparative Analysis* portion of this study.

Advantages: The ESAL/LEF provides a relatively transparent way of estimating damage to a network of bridges in a State or region without having detailed data on each and every bridge in the State or region.

Disadvantages: The ESAL is tied to the 18,000 lb. standard axle load and to a pavement-based exponential power. Furthermore, it employs a power exponent that is not a factor in the mathematical sense, implying the function was not well understood. As a result, the ESAL/LEF is not used in this bridge comparative analysis.

### ***Pros and Cons of Cost Responsibility Assignment Methods***

The background of each of these methods is related and has been chronicled elsewhere in this document. However, a brief statement of the methodology is necessary in order to highlight the pros and cons.

#### Incremental/Federal Method (as described in NCHRP Report 495, 2003)

The concept is rather simple; however, its implementation is very complex and becomes increasingly so for large systems. The cost impacts are categorized as impacts to:

- 1) Existing bridge superstructures,
- 2) New bridge superstructures,
- 3) Steel fatigue details, and
- 4) Reinforced concrete deck crack propagation (termed “reinforced concrete fatigue” in report 495).

The process for all cost categories includes selecting a number of bridges in the region or State (guidelines for the selection of these bridges are provided). These bridges would need to be load rated in accordance with AASHTO’s *Manual of Bridge Evaluation*. To estimate the cost impact of the truck traveling over the bridge, if the rating factor is less than 1.0, then the bridge is considered to be inadequate for the truck, and one of five action options could be selected: 1= do nothing, 2 = rehab or retrofit, 3 = post, 4 = combination of 2 and 3, or 5 = replace. The cost of the action then is estimated for that truck on that type of bridge. The same general steps are repeated for the four cost categories with variations in the actual details.

According to the findings of NCHRP Report 495, “The Federal...method is more advantageous at the State level or a local level [for which] cost impact estimation could be conducted in more detail, because more detailed bridge data are available and the number of bridges becomes smaller.” Conversely stated, the disadvantage of this method is that the level of detail and data needed to analyze bridges at the national scale would be time and cost prohibitive. In addition, the methodology outlined in the Report provides bridge selection guidelines that may end up excluding bridges when there is a large population of bridges in the study area as is the case with this Study.

The method allows one to prescribe a course of action that has a certain cost to perform, but it does not provide for a measure of the actual level of damage. The effective use of this method requires a familiarity with each State’s repair philosophies and practices. For instance, does the State lean towards repair and preservation or does it favor proactive replacement of deficient structures? With respect to the term “practice,” the threshold that visible condition level triggers a finding of failure by different owners is being referenced. Report 495 did introduce a “probabilistic approach,” a formulaic expression (NCHRP 495, Equations 3.4.2.7 and 3.3.3.1) to deal with the uncertainty with respect to reported physical test results and practice (NCHRP Report 495, pages 46 & 51, Section 3.4.3). However, the sheer scope of work relative to its application to large numbers of specific, real bridges is at this time untenable for use in this study.

With respect to the fatigue methods described in this document, the document itself addresses its own limitations in that “... due to uncertainty observed in reported physical test results and practice in determining end of service life...the real service life of the deck is not certain.” The report recognizes the lack of available data in a consistent format that is sufficient to implement the method in a large, multi-state region or national study.

Washington, DC DDOT, 2010 District Wide Truck Safety Enforcement Plan: Task 3 - Infrastructure Impacts of Overweight Trucks

The bridge cost allocation portion of this study was based on a model that used a bridge deterioration mechanism prevalent in the Northern Region or the “Rust Belt” of the United States, where States use chlorides in de-icing roadways and bridges. In this region, chloride intrusion plays a major role in general bridge deterioration and specifically in bridge deck deterioration. The study employed ESAL/LEFs as its allocator for estimating damage and assigning cost.

The NBI database was used to obtain most of the bridge data, minus the structural details. The next step was to determine the traffic stream and volume (mix and number of vehicles – truck class specific). The District provided raw WIM data from three WIM stations in the District and law enforcement citations on non-compliant trucks, but this did not provide enough breadth of data to reach any meaningful conclusions. The research team used WIM data in the form of axle load weight increments and counts for each vehicle class. District axle load charts were used to determine which sets of axle weight increments would be considered compliant or non-compliant. Accordingly, a relative damage distribution profile was determined (by percent) of legal and over-weight trucks by vehicle class (TMG Vehicle Classes 4 through 13).

An analysis of annualized capital costs was conducted for the bridges included in the study. Based on the District’s truck routing map, bridge structures that were not on the truck routes and thus would not be impacted were excluded, as were parkway bridges and tunnels. A detailed, annualized cost estimate was developed for the remaining 139 bridges.

The final step was to apply the truck distribution profile of the 10 truck vehicle classifications to the bridge costs, providing a clear picture of the impact of trucks (both compliant and non-compliant) on the District’s bridges.

The advantages of this type of study are self-evident based on the results obtained. However, the following speaks to two primary weaknesses in that study and mitigations that have been introduced in this present study: the methodology used the ESAL/LEF allocator to assign cost responsibility, and, as stated above, this approach is somewhat flawed as it ties damage to an arbitrary standard axle load and to a powered exponent that was not well understood.

***Comparison of Impacts from Vehicles that Operate Within and Above Size and Weight Limits***

While comparing the impacts of trucks with a GVW at or below current Federal limit of 80,000 pounds with trucks that operate above those limits, it is important to consider that GVW is not the sole, key consideration in conducting such a comparison. One study evaluated in the desk scan observed that traffic induced flexural stress does not necessarily increase with GVW but is highly related to axle weights and configurations. Another study noted that shorter spans show

little correlation between GVW and moment effect. The study goes on to point out that the correlation improves as the span length increases. For example, the study found that when comparing truck induced moment on spans shorter than 60 feet, there is very little difference in the moments induced by 5-axle and 11-axle trucks. However, the study goes on to point out that for spans greater than 60 feet, as the span length increases the moments induced by 11-axle trucks are significantly higher than those induced by 5-axle trucks.

Axle weight is a key factor used in calculating stress cycles and estimating bridge deck wear, and GVW must be combined with the number of axles that the configuration being evaluated has as well as the spacing between the axles when conducting structural analysis, as was done in this part of the Study.

In completing the structural analysis performed in this bridge structure comparative study, the AASHTOWare Bridge Rating® (ABrR) program was used to analyze the 490 bridges for the base case (GVW  $\leq$  80,000 lb.) and for the proposed alternative truck configurations in the six scenarios (alternative scenario, GVW  $>$ 80,000 lb.). The USDOT study team calculated estimates of the cost to strengthen or replace certain bridges unable to accommodate the heavier truck configurations evaluated, and these are presented in this Report.

In completing the fatigue analysis, the results of this comparative analysis indicate that relatively higher axle loads and/or closely spaced axles negatively impact fatigue life when compared to the two 80,000 control vehicles. The number of stress cycles in a structure is proportional to the number of trucks that cross the bridge during its service life. The study team performed fatigue life evaluations based on the assumptions that each truck loading cycle causes some damage. The damage caused by each truck depends on the weight, the bridge's span length, and member section properties. In this area of the study, the study team investigated the effect of trucks that exceed Federal weight limits) on bridge decks. One approach was to look at States that allowed heavier trucks in comparison to States that do not allow heavier than Federal legal limit trucks. Efforts in this area of the Study were not productive due to the reasons stated above—e.g., variations in States' approaches, allocators used, etc.—and because all States do issue overweight permits for loads heavier than the legal maximum. Furthermore, bridge deck thickness, girder or floor-beam spacing, and other general characteristics differ from one bridge deck to another.

**CHAPTER 2 – STRUCTURAL ANALYSIS AND BRIDGE POSTING ASSESSMENT**

**2.1 Overview**

A total of 490 bridges out of a pool of more than 500 candidates were selected for inclusion into the final sample database representing the inventory of bridges on the National Highway System (NHS). The breakdown of this database was determined primarily based on the distribution of the bridge types on the NHS. Bridge selection was further refined to include additional considerations including year built, maximum span length, and live load capacity to get a diverse sample space. The breakdown of the bridges in the sample database is given in **Table 1**.

**Table 1: Breakdown of the Bridges in the Sample Database**

Bridge Type		IS		Other NHS		TOTAL	
		# of Bridges	Frequency (%)	# of Bridges	Frequency (%)	# of Bridges	Frequency (%)
1	Reinforced Concrete Slab	18	11.8	40	11.9	58	11.8
2	Pre-stressed Concrete Beam/Girder Simple Span	30	19.6	39	11.6	69	14.1
3	Pre-stressed Concrete Beam/Girder Continuous Span	16	10.5	32	9.5	48	9.8
4	Steel Beam/Girder Simple Span (L < 100 ft.)	14	9.2	38	11.3	52	10.6
5	Steel Beam/Girder, Simple Span (L >= 100 ft.)	19	12.4	17	5.0	36	7.3
6	Steel Beam/Girder, Continuous Spans (L < 100 ft.)	21	13.7	28	8.3	49	10.0
7	Steel Beam/Girder, Continuous Spans (L >= 100 ft.)	11	7.2	33	9.8	44	9.0
8	Girder Floor-beam Systems	2	1.3	9	2.7	11	2.2
9	Reinforced Concrete Tee Beam	11	7.2	42	12.5	53	10.8
10	Box Beams	10	6.5	44	13.1	54	11.0
11	Through Truss	1	0.7	15	4.5	16	3.3
<b>TOTAL</b>		<b>153</b>	<b>100.0</b>	<b>337</b>	<b>100.0</b>	<b>490</b>	<b>100.0</b>

Per the overarching project assumptions stated in the *Volume II: Modal Shift Comparative Analysis*, with the exception of the triple trailer combinations, the study parameters assume the scenario vehicles are able to travel wherever the control vehicles could operate. For analytical purposes triple trailer combinations (Scenarios 5 and 6) are assumed to be restricted to a 74,500 mile network of Interstate and other principal arterial highways. The structural analyses assessed in this study take into account the findings related to changes in vehicle use patterns that the study team projected would result from the availability of alternative vehicle configurations.

The *AASHTOWare Bridge Rating®* (ABrR) program was used to analyze the 490 bridges for the base case, (GVW ≤ 80,000 lbs. compared to GVW > 80,000 lbs.) and for the proposed alternate vehicles (alternate scenario, GVW >80,000 lb.). The load and resistance factor rating (LRFR) methodology was employed in the analysis for all bridge types, except girder-floor-beam

systems and through trusses, where the load factor rating (LFR) method was used, since the ABrR software does not currently support LRFR methodology for these two bridge types.

Rating factors were extracted for alternative truck configurations and 3-S2 and 2-S1-2 control vehicles for both flexure and shear, and the results were investigated statistically. For each bridge type, the number of bridges having a rating factor less than 1.0 was extracted for all alternative truck configurations. This was performed for Interstate bridges and for other bridges on the NHS, separately. Next, the percentage of bridges that have posting issues for each bridge type, by each truck, was calculated by dividing the number of bridges with a RF less than 1.0 by the total number of bridges of that bridge type in the sample database.

In order to project the number of bridges that may need posting in the entire NHS inventory, the actual number of bridges in the NHS inventory for each bridge type was determined. The projected number of bridges to be posted in each category was calculated by multiplying the percentage of posted bridges in the sample database for a given bridge type by the actual number of bridges of the same type in the NHS inventory. Summary results from this statistical projection are given in **Table 2**.

**Table 2: Projected Number of Posted Bridges for the Entire NHS Inventory**

NUMBER OF BRIDGES IN THE NBI		LOAD RATING RESULTS					PROJECTED NUMBER OF BRIDGES W/ POSTING ISSUES FOR ENTIRE INVENTORY	
# of IS Bridges in the NBI	# of Other NHS Bridges in the NBI	# of IS Bridges Rated	# of Other NHS Bridges Rated	Vehicle Configuration	IS Bridges Rated w/ RF < 1.0 (%)	Other NHS Bridges Rated w/ RF < 1.0 (%)	# of IS Bridges w/ Posting Issues	# of Other NHS Bridges w/ Posting Issues
45417	43528	153	337	Scenario 1	3.3%	5.0%	1485	2194
				Scenario 2	3.3%	7.7%	1485	3360
				Scenario 3	4.6%	9.5%	2080	4135
				Scenario 4	2.6%	3.0%	1185	1293
				Scenario 5	2.0%	0.9%	890	387
				Scenario 6	6.5%	5.6%	2970	2455

The table above shows both the percentages and the actual number of bridges that have posting issues.

In order to estimate the probable one-time cost effect of employing alternative truck configurations, a methodology was developed and presented in this report. It estimates the increase in cost relative to the base vehicles. An RF of 1.0 was set as the acceptance criteria when determining bridge improvement needs. It should be noted the one-time cost of bridge improvements addressed herein could pertain to either superstructure strengthening or superstructure replacement triggered by the need to increase live load capacity. The choice of strengthening vs. replacement would depend on superstructure type and whichever is the more economical alternative.

## **2.2 Bridge Inventory Used In the Structural Analysis**

### ***Introduction***

The diversity of the bridge infrastructure in terms of age and design parameters (including structural type, materials of construction, width, length, etc.) is broad. Experience has shown the performance of any specific bridge is dependent on complex interactions of multiple factors, many of which are closely linked and include the following: original design parameters and specifications, bridge type, materials of construction, geometry, design load, and incidence of corrosion or other deterioration processes.

The sample database of bridges was developed to gain a diverse representation of the bridges that make up the NHS inventory, which are broken down by type in **Table 3**. The bridge types in this table were determined based on the material of construction, distinct structural behavior, and span configurations (L denotes the longest span length).

**Table 3: Breakdown of the Bridges on the NHS**

Bridge Type		IS		Other NHS		TOTAL	
		# of Bridges	Frequency (%)	# of Bridges	Frequency (%)	# of Bridges	Frequency (%)
1	Reinforced Concrete Slab	5101	11.2%	4903	11.2%	10004	11.2%
2	Pre-stressed Concrete Beam/Girder Simple Span	9382	20.6%	11079	25.4%	20461	23.0%
3	Pre-stressed Concrete Beam/Girder Continuous Span	2131	4.7%	3817	8.8%	5948	6.8%
4	Steel Beam/Girder Simple Span (L < 100 ft.)	6183	13.6%	5195	11.9%	11378	12.8%
5	Steel Beam/Girder, Simple Span (L > = 100 ft.)	2847	6.3%	1983	4.6%	4830	5.4%
6	Steel Beam/Girder, Continuous Spans (L < 100 ft.)	6755	14.9%	3958	9.1%	10713	12.0%
7	Steel Beam/Girder, Continuous Spans (L > = 100 ft.)	4255	9.4%	3158	7.3%	7413	8.3%
8	Girder Floor-beam Systems	774	1.7%	553	1.3%	1327	1.5%
9	Reinforced Concrete Tee Beam	2639	5.8%	3499	8.0%	6138	6.9%
10	Box Beams	5248	11.6%	5094	11.7%	10342	11.6%
11	Through Truss	102	0.2%	289	0.7%	391	0.5%
<b>TOTAL</b>		<b>45,417</b>	<b>100%</b>	<b>43,528</b>	<b>100%</b>	<b>88,945</b>	<b>100%</b>



A total of 490 bridges were selected for the sample database representing the NHS inventory. In order to verify whether the number of bridges in the sample database is adequate, the study team used Slovin's formula:

$$n = \frac{N}{(1 + Ne^2)}$$

Where:

N = the number of bridges in the total population

e = the margin of error

n = the required number of bridges in the sample database (which corresponds to the confidence level per the margin of error provided).

For a 95 percent confidence level, the required number of bridges in the sample database can be calculated as:

$$n = \frac{88,945}{(1 + 88,945 \times 0.05^2)} = 398$$

Thus, it can be stated that by using 490 bridges in the sample database, a confidence level of more than 95 percent was achieved. The exact confidence level of the sample database can be computed by rewriting the Slovin's formula as:

$$e = \sqrt{\frac{N - n}{Nn}} = \sqrt{\frac{88,945 - 490}{88,945 \times 490}} = 0.0451$$

$$1 - e = 1 - 0.0451 = 95.4\% \text{ Confidence Level}$$

The breakdown of the sample database was determined primarily based on the distribution of bridge types in the NHS inventory. Bridge selection was further refined to include additional considerations including year built, maximum span length, and live load capacity to get a diverse sample space. The breakdown of the final sample database of bridges used in this study is shown in **Table 4**.

**Table 4: Breakdown of the Bridges in the Sample Database**

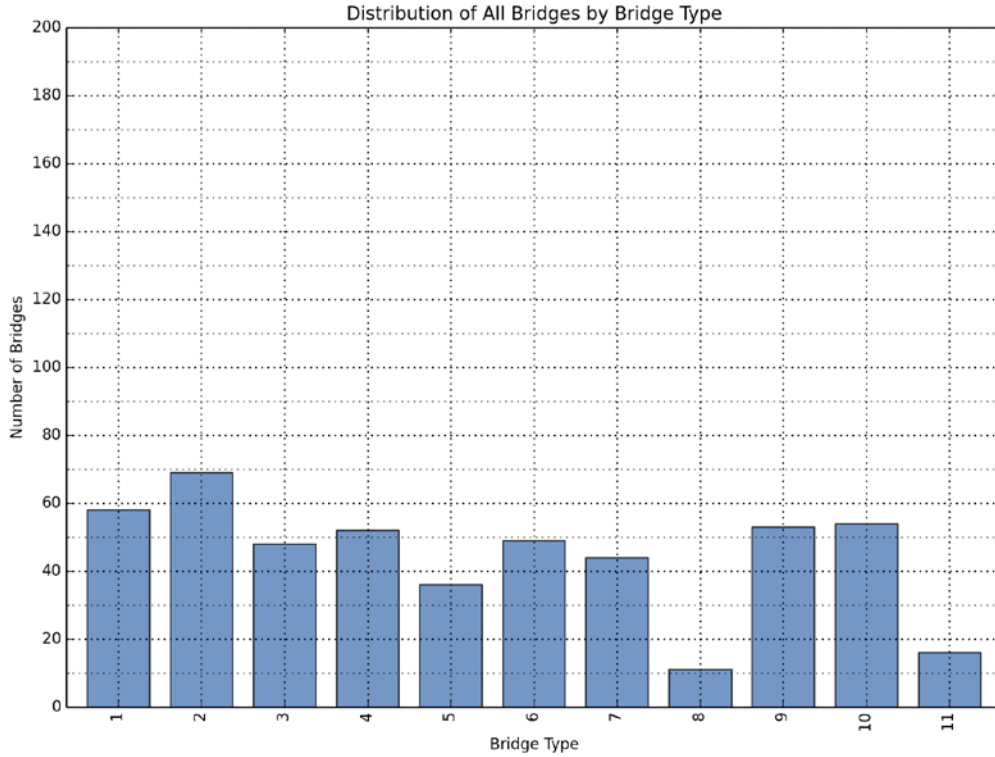
Bridge Type		IS		Other NHS		TOTAL	
		# of Bridges	Frequency (%)	# of Bridges	Frequency (%)	# of Bridges	Frequency (%)
1	Reinforced Concrete Slab	18	11.8	40	11.9	58	11.8
2	Pre-stressed Concrete Beam/Girder Simple Span	30	19.6	39	11.6	69	14.1
3	Pre-stressed Concrete Beam/Girder Continuous Span	16	10.5	32	9.5	48	9.8
4	Steel Beam/Girder Simple Span (L < 100 ft.)	14	9.2	38	11.3	52	10.6
5	Steel Beam/Girder, Simple Span (L >= 100 ft.)	19	12.4	17	5.0	36	7.3
6	Steel Beam/Girder, Continuous Spans (L < 100 ft.)	21	13.7	28	8.3	49	10.0
7	Steel Beam/Girder, Continuous Spans (L >= 100 ft.)	11	7.2	33	9.8	44	9.0
8	Girder Floor-beam Systems	2	1.3	9	2.7	11	2.2
9	Reinforced Concrete Tee Beam	11	7.2	42	12.5	53	10.8
10	Box Beams	10	6.5	44	13.1	54	11.0
11	Through Truss	1	0.7	15	4.5	16	3.3
<b>TOTAL</b>		<b>153</b>	<b>100.0</b>	<b>337</b>	<b>100.0</b>	<b>490</b>	<b>100.0</b>

Bridges were selected from all regions of the country. The sample database consists of bridges from 11 States as shown in **Table 5**. Span lengths and age of construction of these bridges are also described in the tables and plots to follow.

**Table 5: Breakdown of the Sample Database by State**

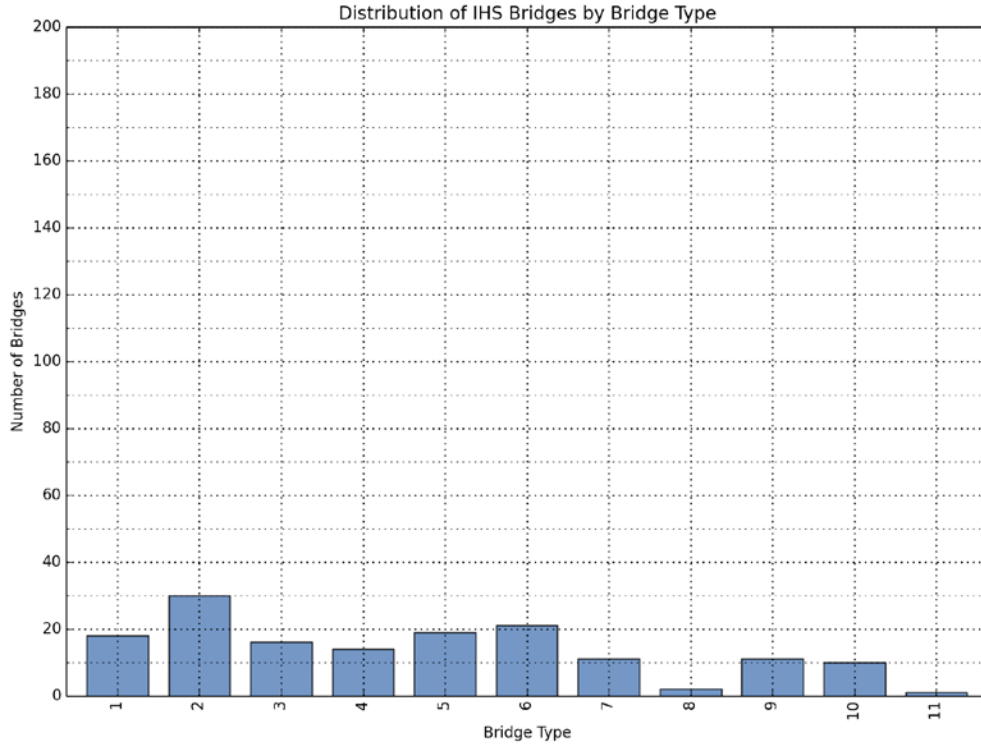
States	# of Bridges	Frequency (%)
Illinois	96	19.6
New York	103	21.0
Virginia	23	4.7
Michigan	66	13.5
Louisiana	20	4.1
New Mexico	34	6.9
Utah	74	15.1
S. Dakota	14	2.9
Alabama	33	6.7
New Jersey	23	4.7
Idaho	4	0.8
<b>TOTAL</b>	<b>490</b>	<b>100.0</b>

The distribution of the bridges in the sample database is shown in **Figure 1** through **Figure 3** for all bridges, Interstate bridges, and other bridges on the NHS, respectively.



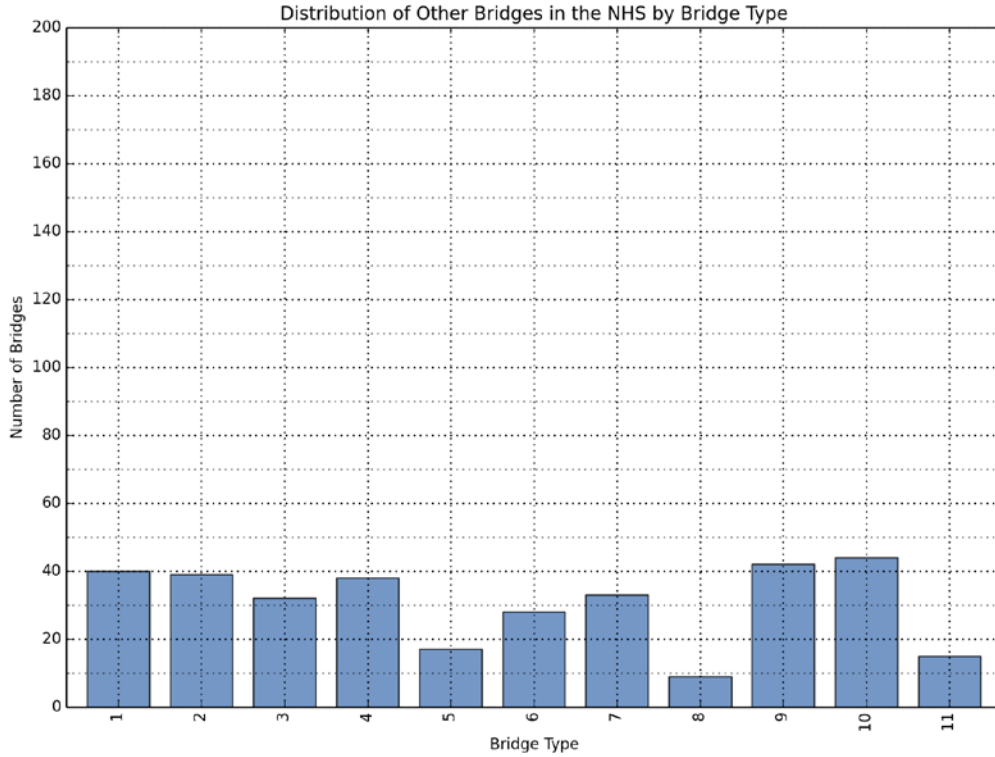
**Figure 1: Distribution of All Bridges by Bridge Type.**

(See Table 3 for description of bridge types)



**Figure 2: Distribution of Interstate Bridges by Bridge Type.**

(See Table 3 for description of bridge types)



**Figure 3: Distribution of other bridges on the NHS by bridge type.**  
(See Table 3 for description of bridge types)

***Distribution of Bridges by Span Length***

The distribution of the bridges in the sample database by span length is listed in **Table 6**. The bulk of the bridges analyzed in this study have a span length less than or equal to 150 ft. (91.4 percent for Interstate and other NHS bridges combined). Span length distributions are illustrated in **Figure 4** through **Figure 6** for all bridges, Interstate bridges, and other bridges on the NHS, respectively.

**Table 6: Distribution of the Bridges by Span Length**

Span Length	IS		Other NHS		TOTAL	
	# of Bridges	Frequency (%)	# of Bridges	Frequency (%)	# of Bridges	Frequency (%)
<50	35	21.6	111	33.8	146	29.8
50-100	77	47.5	136	41.5	213	43.5
100-150	33	20.4	56	17.1	89	18.2
150-200	7	4.3	10	3.0	17	3.5
200-250	4	2.5	4	1.2	8	1.6
250-300	2	1.2	6	1.8	8	1.6
300-350	0	0.0	2	0.6	2	0.4
350-400	1	0.6	2	0.6	3	0.6
400-450	0	0.0	0	0.0	0	0.0
450-500	1	0.6	0	0.0	1	0.2
>500	2	1.2	1	0.3	3	0.6
<b>TOTAL</b>	<b>162</b>	<b>100.0</b>	<b>328</b>	<b>100.0</b>	<b>490</b>	<b>100.0</b>

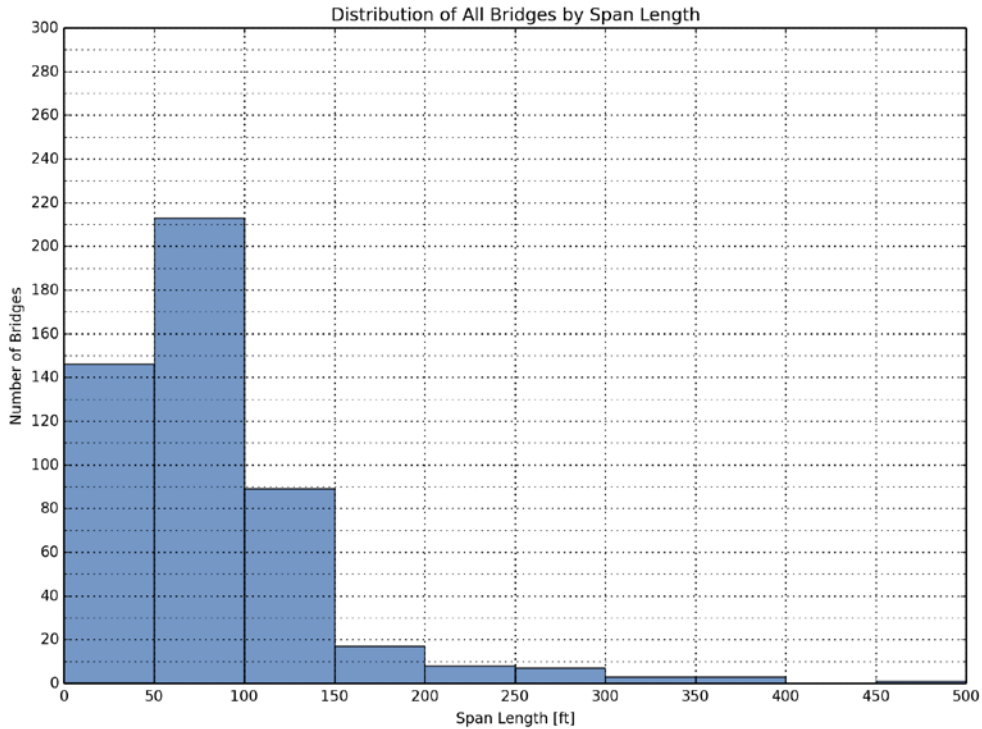


Figure 4: Distribution of All Bridges by Span Length

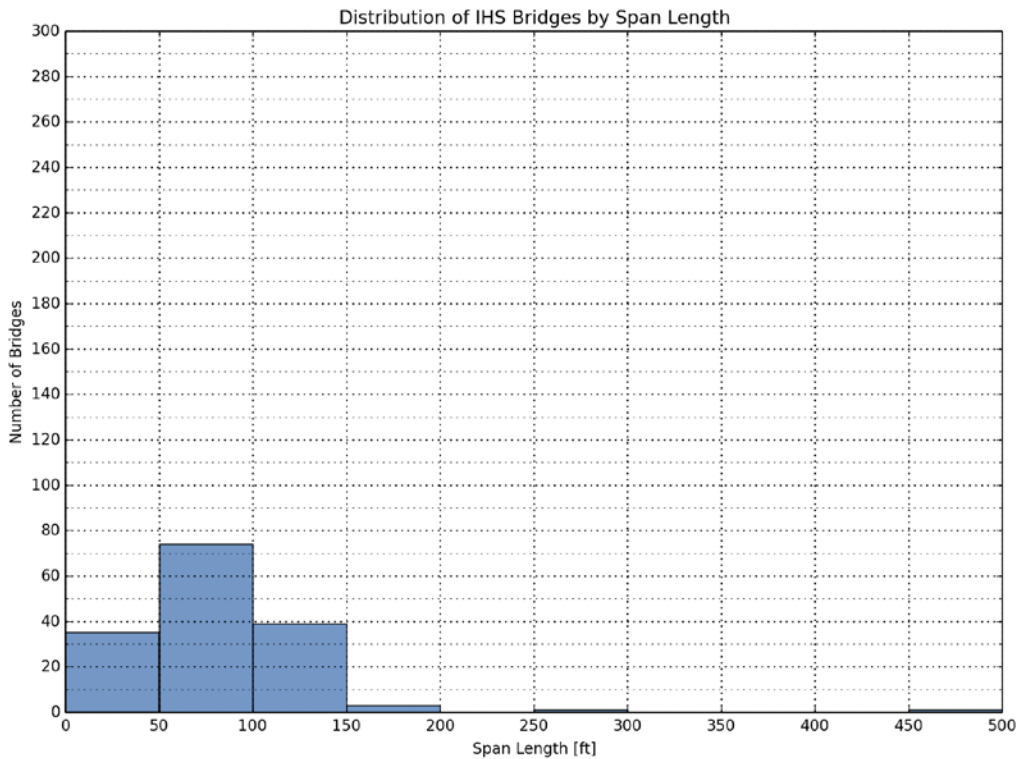
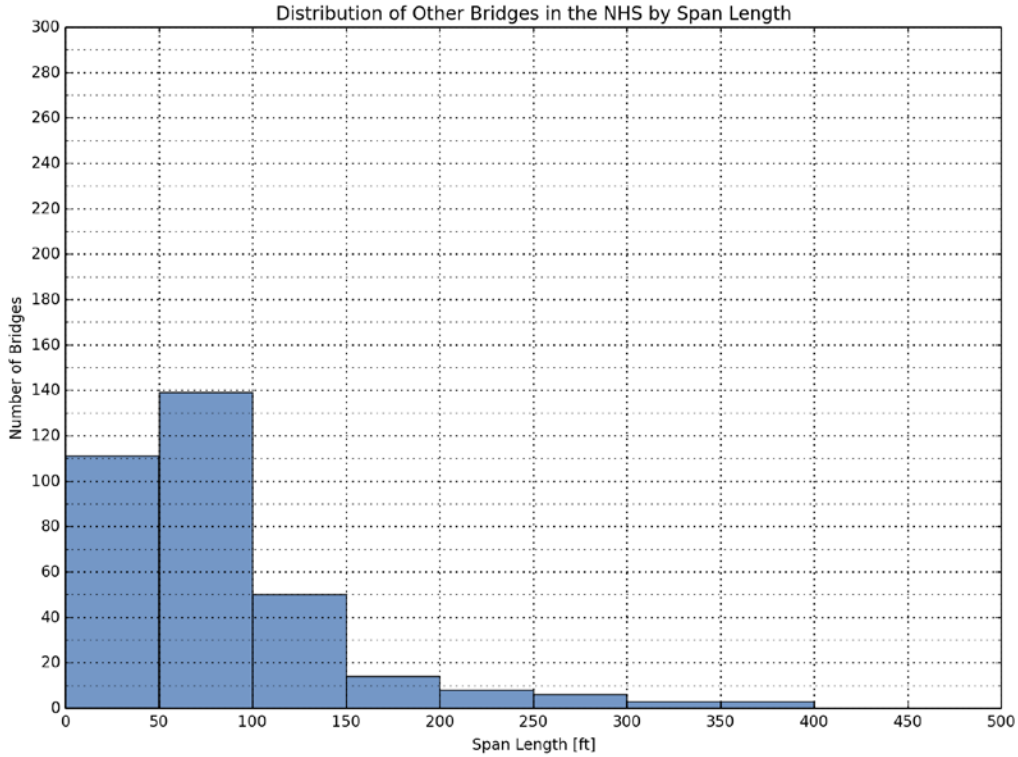


Figure 5: Distribution of Interstate Bridges by Span Length



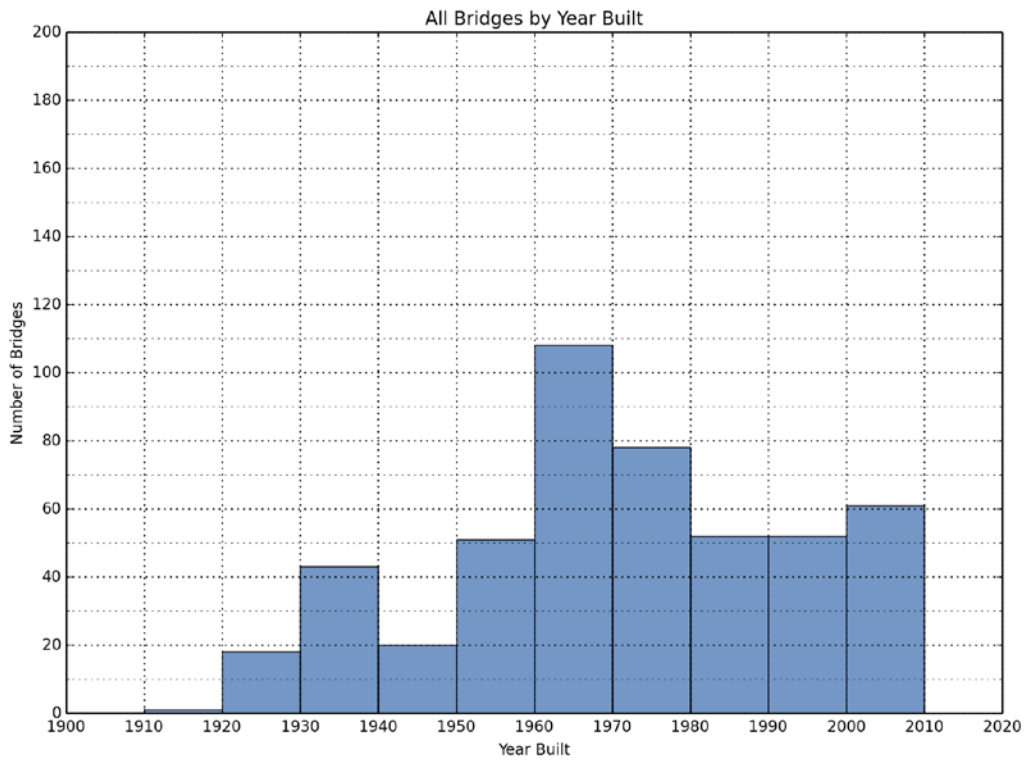
**Figure 6: Distribution of Other Bridges on the NHS by Span Length**

***Distribution of Bridges by Year Built***

The distribution of the bridges in the sample database by year built is listed in **Table 7**. Those designated “other NHS bridges” have an approximately uniform distribution between 1920 and 2010. On the other hand, almost no Interstate bridges were recorded before the time interval 1950-1960, and bulk of the Interstate bridges (74.5 percent) analyzed in this study were built between 1950 and 1980. This is due to the fact that the Interstate System was built when President Dwight D. Eisenhower signed the Federal-Aid Highway Act of 1956.

**Table 7: Distribution of the Bridges by Year Built**

Built Year	IS		Other NHS		TOTAL	
	# of Bridges	Frequency (%)	# of Bridges	Frequency (%)	# of Bridges	Frequency (%)
<=1920	0	0.0	2	0.6	2	0.4
1920-1930	0	0.0	20	5.9	20	4.1
1930-1940	0	0.0	42	12.5	42	8.6
1940-1950	0	0.0	21	6.2	21	4.3
1950-1960	21	13.7	41	12.2	62	12.7
1960-1970	58	37.9	45	13.4	103	21.0
1970-1980	35	22.9	37	11.0	72	14.7
1980-1990	18	11.8	38	11.3	56	11.4
1990-2000	11	7.2	40	11.9	51	10.4
>2000	10	6.5	51	15.1	61	12.4
<b>TOTAL</b>	<b>153</b>	<b>100.0</b>	<b>337</b>	<b>100.0</b>	<b>490</b>	<b>100.0</b>



**Figure 7: Distribution of All Bridges by Built Year**

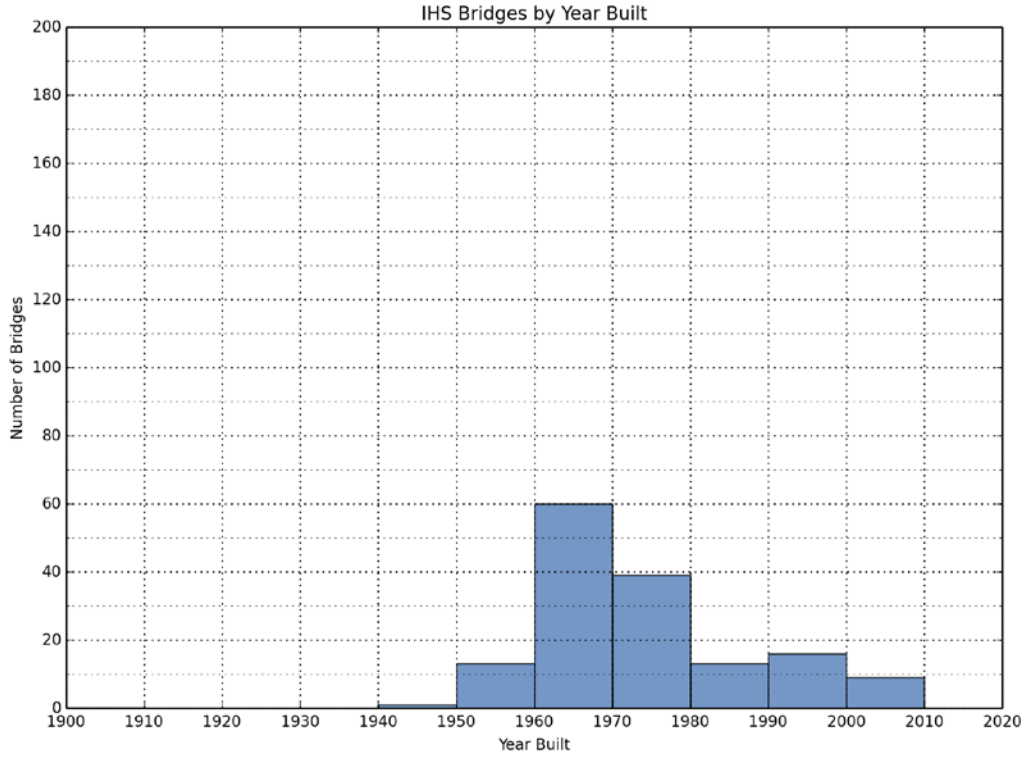


Figure 8: Distribution of Interstate Bridges by Built Year

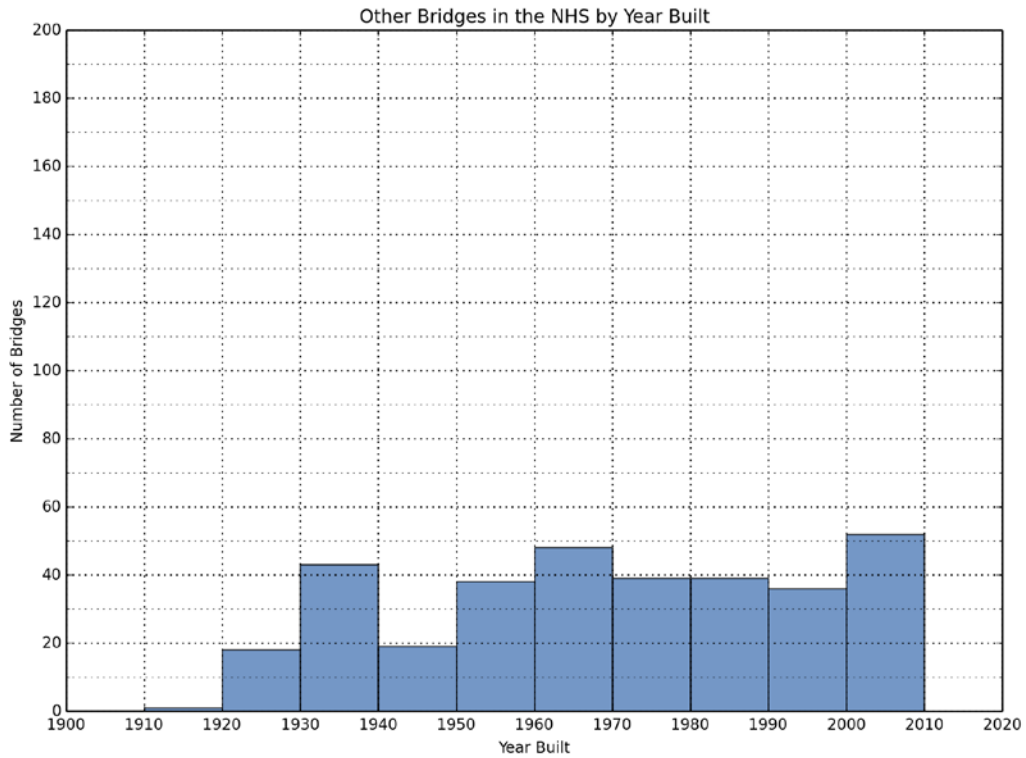


Figure 9: Distribution of Other Bridges on the NHS by Built Year



### 2.3 Load Rating Results For All Bridges

#### *Load Rating Results for All Bridge Types (Raw Rating Factors)*

Non-normalized rating factors from each truck are given in **Table 8 and Table 9** for flexural and shear rating factors, respectively. **Table 8 and Table 9** also include the maximum and minimum rating factors observed in the sample database as well as the number of bridges with a rating factor (RF) less than 1.0, which would require load posting.

Average rating factors for each truck are also illustrated in **Figure 10 and Figure 11** for flexure and shear ratings, respectively. These figures show that flexure tends to yield lower rating factors compared to shear. In other words, in most of the bridges in the sample database, load ratings were controlled by flexure. Consistently higher average rating factors were observed for Interstate bridges compared to other bridges on the NHS, although the difference was not found to be very significant. On average, the first group of vehicles (3-S2 and Scenarios 1, 2 and 3) resulted in lower rating factors compared to the second group (2-S1-2 and Scenarios 4, 5 and 6). When the study team investigated trucks within vehicle groups, Scenario 3 and Scenario 6 yielded the lowest rating factors in the first and second group, respectively.

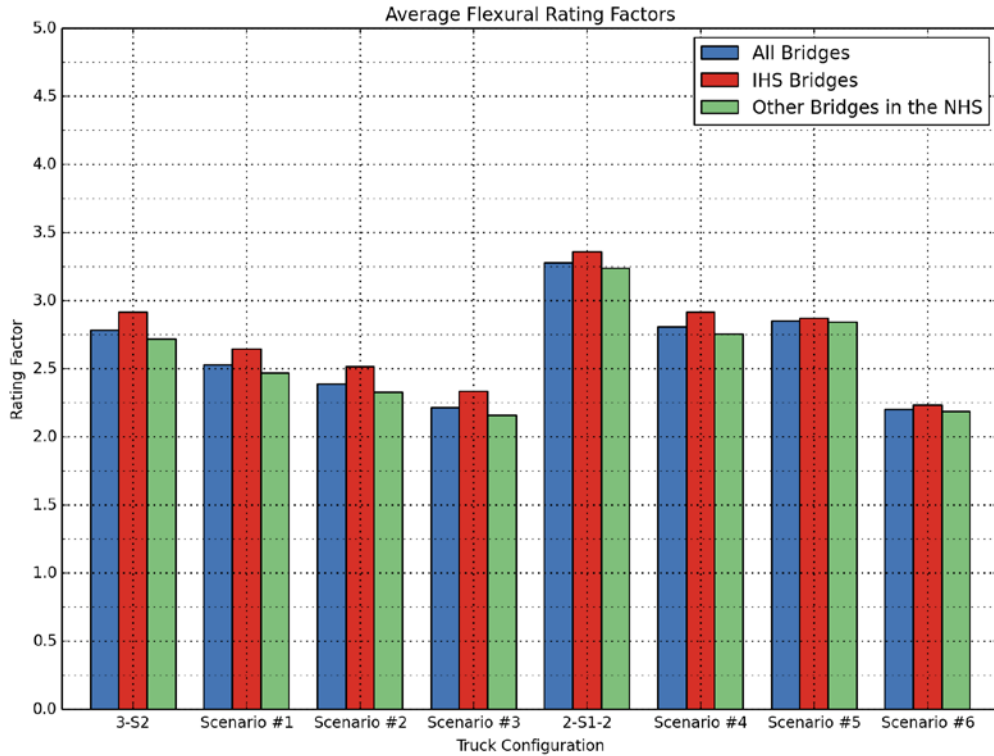
Lastly, the number of bridges with an RF less than 1.0, which would require posting, is shown in **Figure 12** for the flexural case and **Figure 13** for the shear case.

**Table 8: Flexural Rating Result Statistics (GFB and Truss Bridges Not Included)**

		3-S2	Scenario 1	Scenario 2	Scenario 3	2-S1-2	Scenario 4	Scenario 5	Scenario 6
<b>ALL BRIDGES</b>	<b>AVERAGE</b>	2.782	2.526	2.387	2.214	3.279	2.805	2.851	2.202
	<b>MAX</b>	8.429	7.725	7.526	6.969	8.350	7.465	7.698	5.871
	<b>MIN</b>	0.715	0.649	0.589	0.545	0.817	0.751	0.684	0.554
	<b>TOTAL #</b>	463	463	463	463	463	463	463	463
	<b># RF &lt; 1.0</b>	<b>12</b>	<b>16</b>	<b>25</b>	<b>33</b>	<b>2</b>	<b>12</b>	<b>3</b>	<b>22</b>
<b>IS BRIDGES</b>	<b>AVERAGE</b>	2.915	2.645	2.515	2.335	3.361	2.917	2.870	2.235
	<b>MAX</b>	8.337	7.598	7.461	6.943	8.350	7.430	7.023	5.641
	<b>MIN</b>	0.715	0.649	0.631	0.583	0.817	0.751	0.684	0.554
	<b>TOTAL #</b>	150	150	150	150	150	150	150	150
	<b># RF &lt; 1.0</b>	<b>4</b>	<b>4</b>	<b>4</b>	<b>5</b>	<b>2</b>	<b>4</b>	<b>2</b>	<b>7</b>
<b>OTHER BRIDGES ON THE NHS</b>	<b>AVERAGE</b>	2.718	2.469	2.325	2.156	3.239	2.752	2.842	2.186
	<b>MAX</b>	8.429	7.725	7.526	6.969	8.329	7.465	7.698	5.871
	<b>MIN</b>	0.748	0.675	0.589	0.545	1.068	0.824	0.971	0.750
	<b>TOTAL #</b>	313	313	313	313	313	313	313	313
	<b># RF &lt; 1.0</b>	<b>8</b>	<b>12</b>	<b>21</b>	<b>28</b>	<b>0</b>	<b>8</b>	<b>1</b>	<b>15</b>

**Table 9: Shear Rating Result Statistics (GFB and Truss Bridges Not Included)**

		3-S2	Scenario 1	Scenario 2	Scenario 3	2-S1-2	Scenario 4	Scenario 5	Scenario 6
<b>ALL BRIDGES</b>	<b>AVERAGE</b>	3.816	3.442	3.228	2.984	4.591	3.862	4.094	3.133
	<b>MAX</b>	19.86	18.06	17.38	16.06	28.07	22.55	26.26	20.10
	<b>MIN</b>	0.707	0.626	0.591	0.541	0.806	0.728	0.660	0.516
	<b>TOTAL #</b>	463	463	463	463	463	463	463	463
	<b># RF &lt; 1.0</b>	<b>4</b>	<b>7</b>	<b>8</b>	<b>10</b>	<b>1</b>	<b>2</b>	<b>3</b>	<b>8</b>
<b>IS BRIDGES</b>	<b>AVERAGE</b>	3.679	3.319	3.106	2.876	4.330	3.697	3.806	2.911
	<b>MAX</b>	13.58	12.27	11.73	10.99	15.40	13.70	13.12	9.35
	<b>MIN</b>	0.997	0.896	0.837	0.781	1.136	1.014	0.922	0.723
	<b>TOTAL #</b>	150	150	150	150	150	150	150	150
	<b># RF &lt; 1.0</b>	<b>1</b>	<b>1</b>	<b>1</b>	<b>2</b>	<b>0</b>	<b>0</b>	<b>1</b>	<b>3</b>
<b>OTHER BRIDGES ON THE NHS</b>	<b>AVERAGE</b>	3.881	3.501	3.286	3.036	4.715	3.941	4.232	3.240
	<b>MAX</b>	19.86	18.06	17.38	16.06	28.07	22.55	26.26	20.10
	<b>MIN</b>	0.707	0.626	0.591	0.541	0.806	0.728	0.660	0.516
	<b>TOTAL #</b>	313	313	313	313	313	313	313	313
	<b># RF &lt; 1.0</b>	<b>3</b>	<b>6</b>	<b>7</b>	<b>8</b>	<b>1</b>	<b>2</b>	<b>2</b>	<b>5</b>



**Figure 10: Comparison of Average Flexural Rating Factors for Different Truck Types**

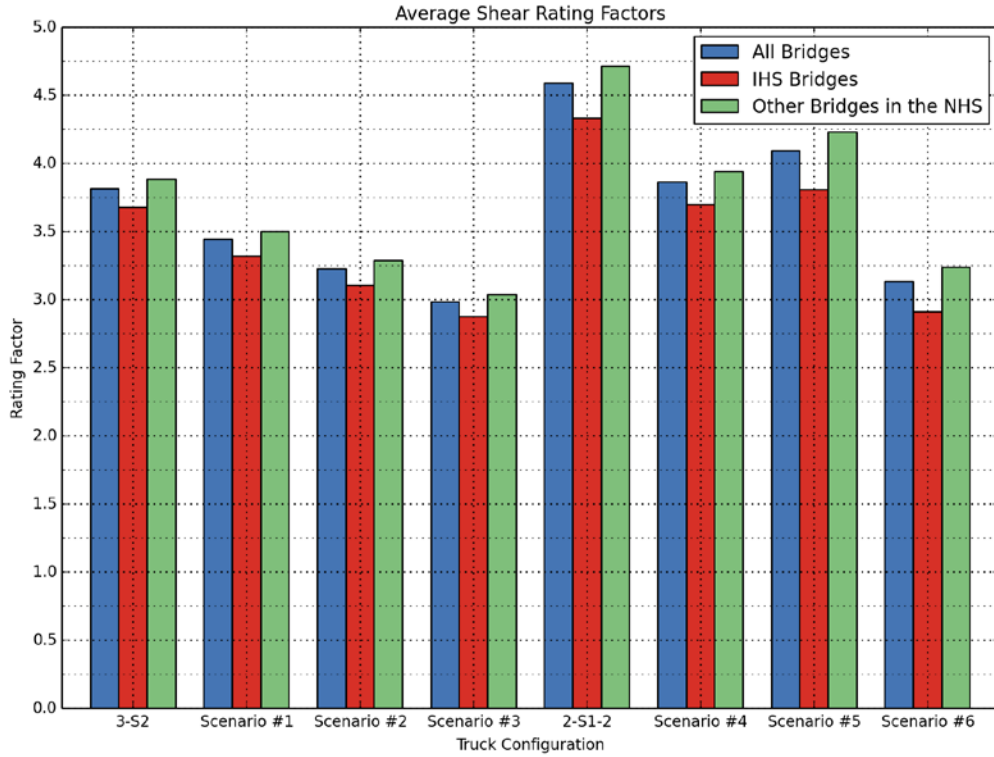


Figure 11: Comparison of Average Shear Rating Factors for Different Truck Types

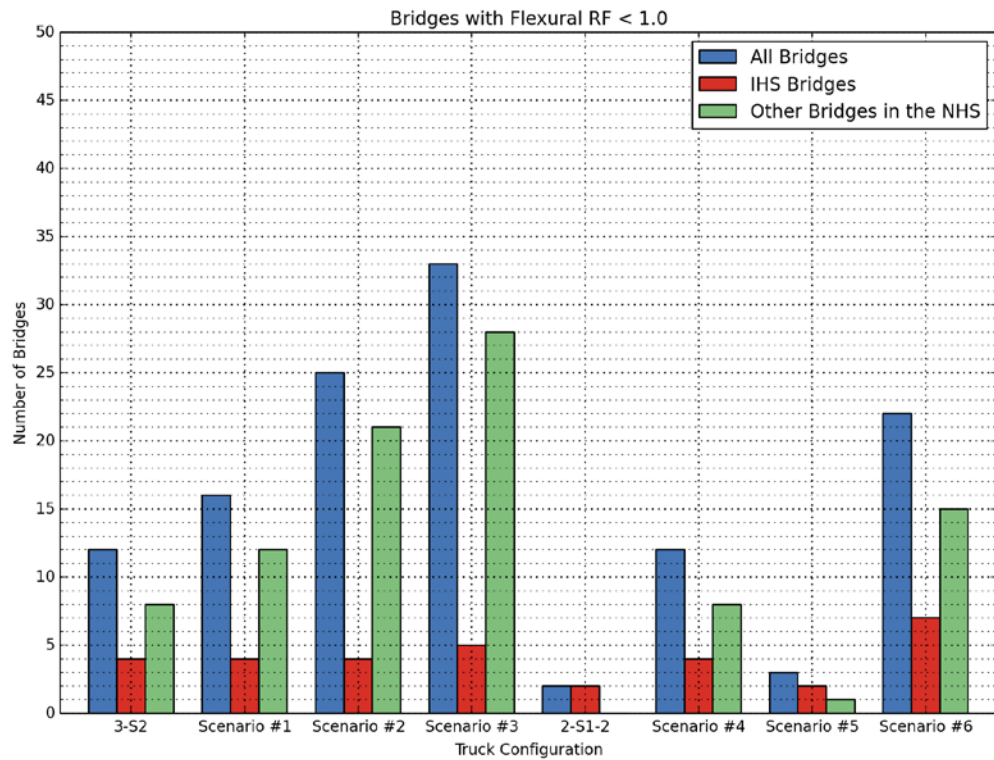
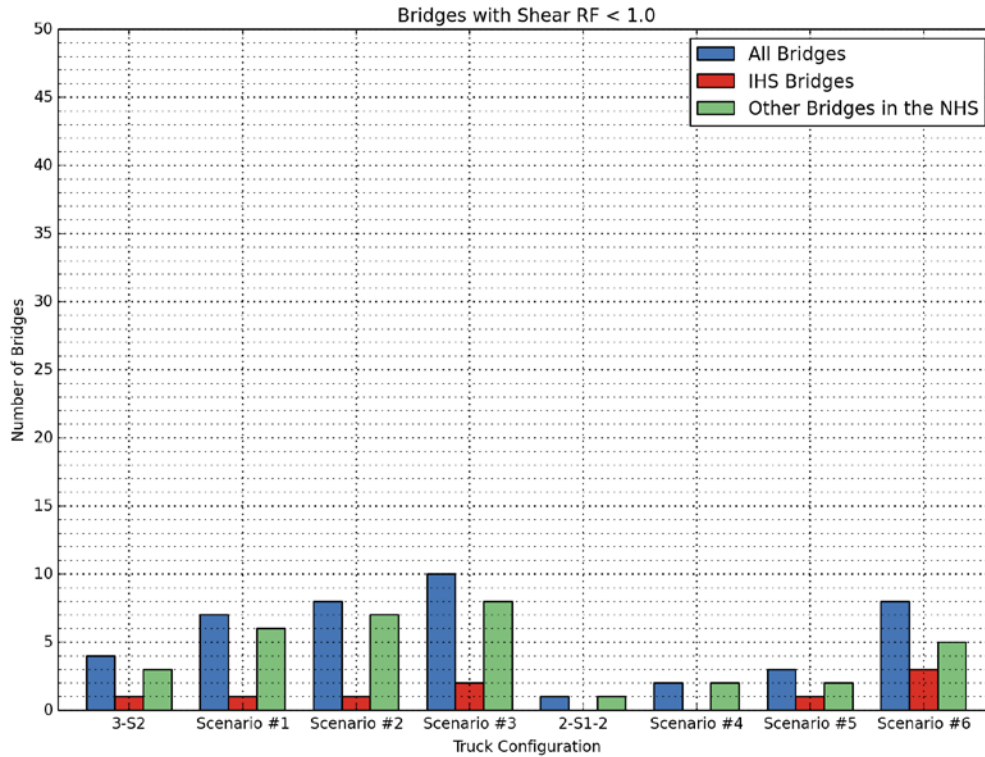


Figure 12: Comparison of Number of Bridges that Require Posting Due to Flexure for Different Truck Types



**Figure 13: Comparison of Number of Bridges that Require Posting Due to Shear for Different Truck Types**

Comparisons of Baseline Trucks with Other Vehicles

Scatter plots were constructed to investigate the comparative rating results from the control vehicles (3-S2 and 2-S1-2) and the alternative truck configurations, where the 3-S2 control vehicle was compared with Scenarios 1, 2 and 3, and the 2-S1-2 control vehicle was compared with Scenarios 4, 5 and 6. These comparisons are shown in **Figure 14** through **Figure 17** for all bridges in the sample database. Separate comparisons for Interstate bridges and other bridges on the NHS are provided in **Appendix C**.

When the 3-S2 control vehicle was compared to alternate truck configuration (Scenarios 1, 2 and 3), a linear correlation was observed in both flexural (**Figure 14**) and shear (**Figure 16**) ratings between the control vehicle and the other three scenarios, but more scatter was observed in shear ratings.

Comparisons of the 2-S1-2 control vehicle and Scenarios 4, 5 and 6 show more scatter compared to the first group of trucks (3-S2 and Scenarios 1, 2 and 3) for both flexure (**Figure 15**) and shear (**Figure 17**), and this effect is much more pronounced in the shear ratings.

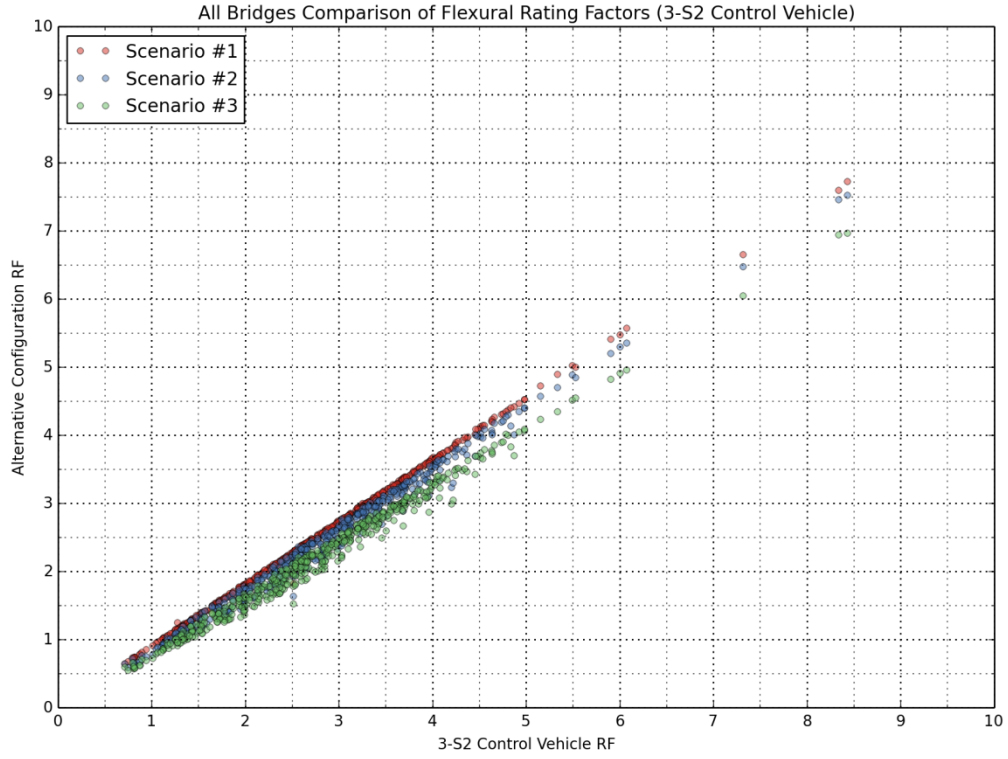


Figure 14: Comparison of Flexural Rating Factors for All Bridges (Compared with 3-S2)

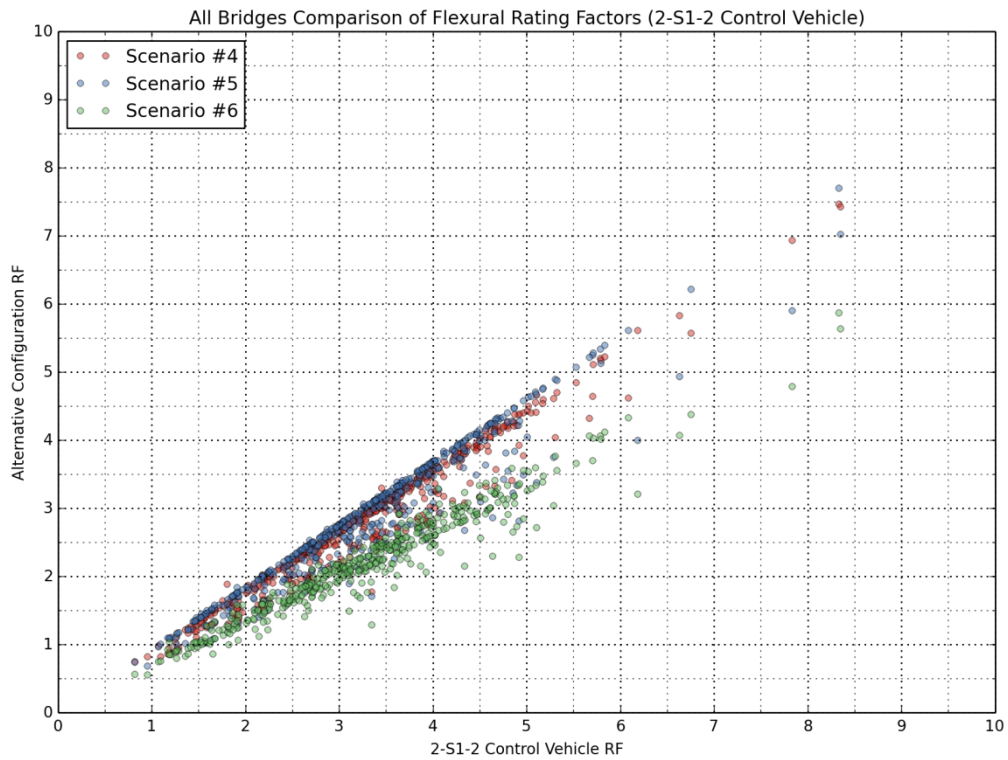


Figure 15: Comparison of Flexural Rating Factors for All Bridges (Compared with 2-S1-2)

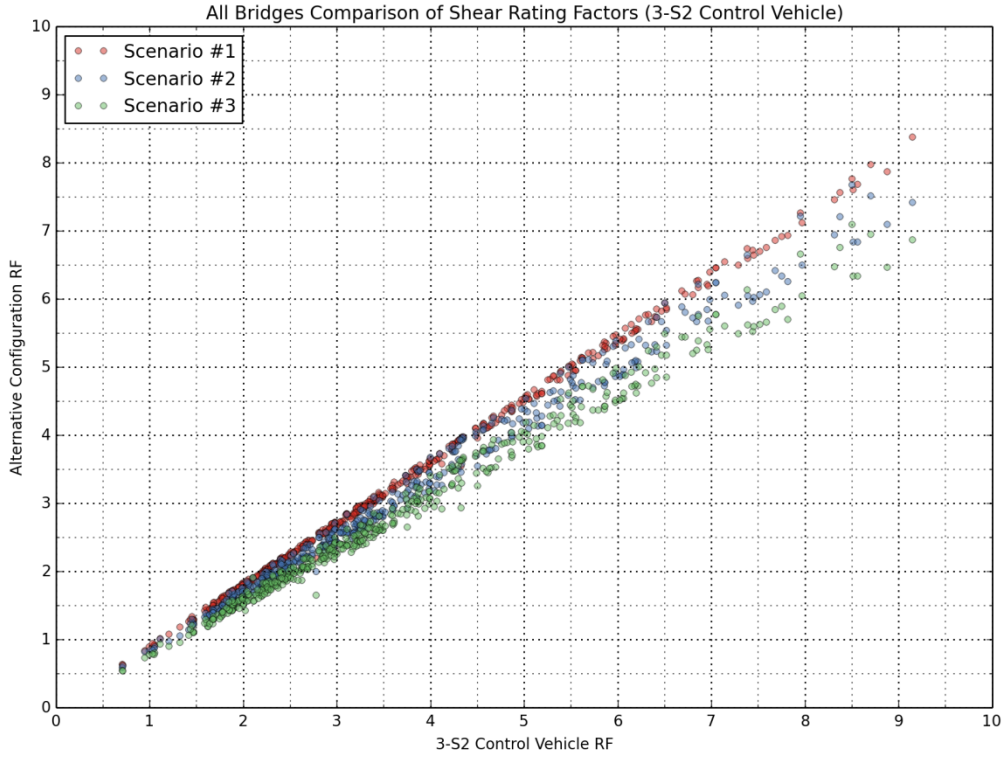


Figure 16: Comparison of Shear Rating Factors for All Bridges (Compared with 3-S2)

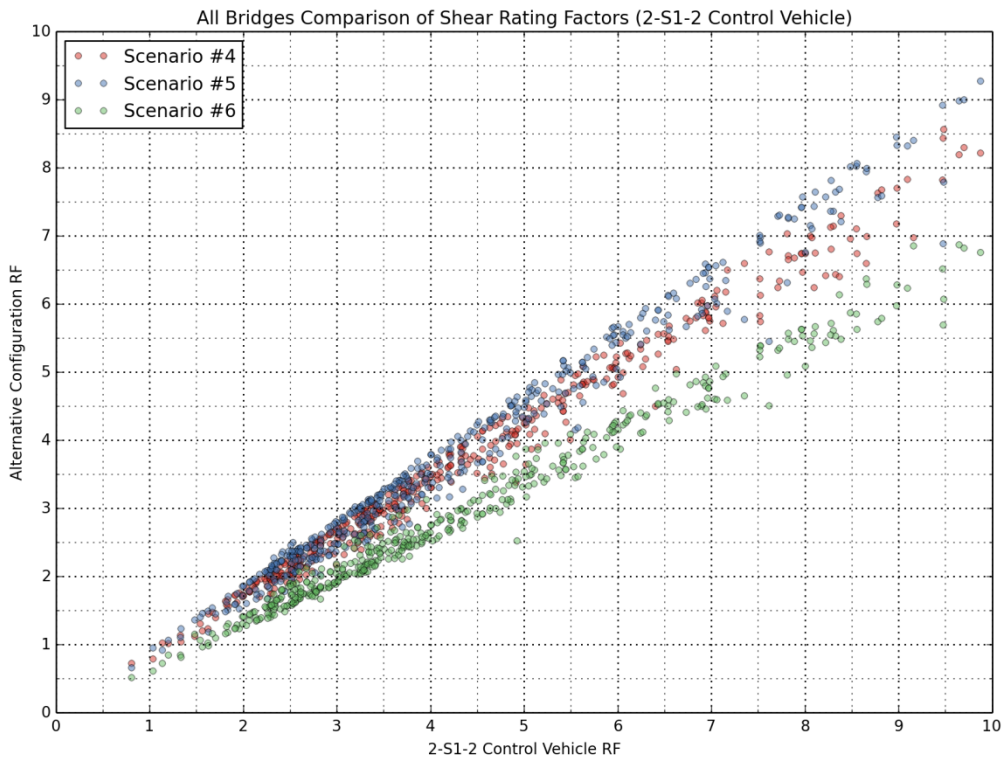


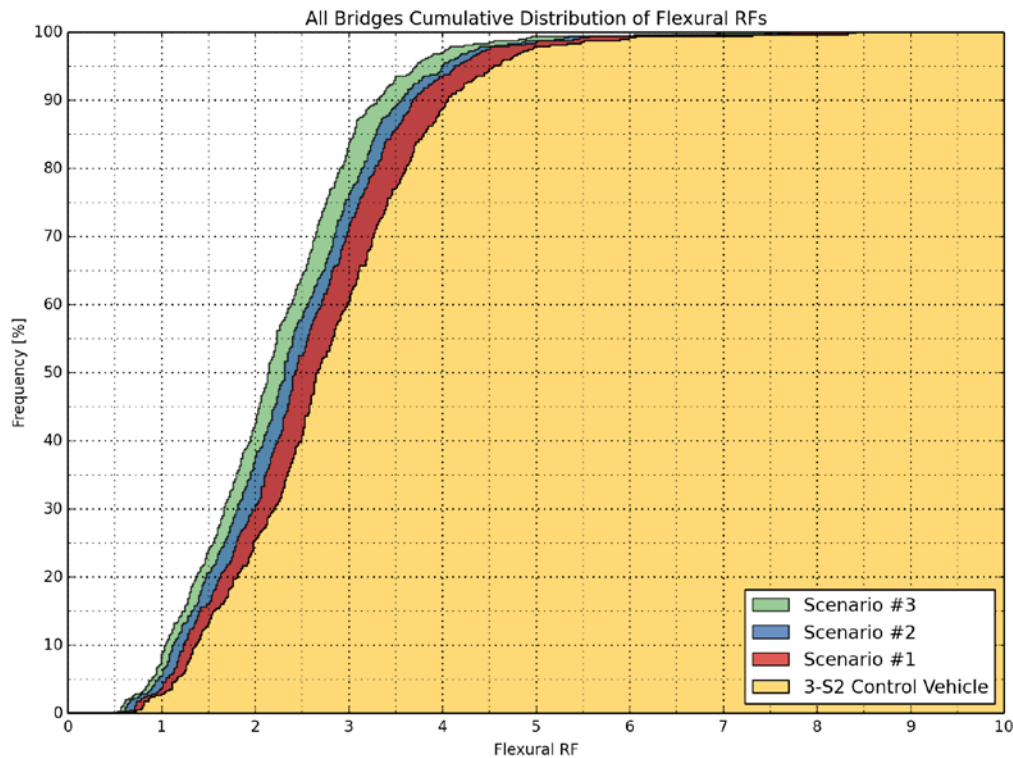
Figure 17: Comparison of Shear Rating Factors for All Bridges (Compared with 2-S1-2)

Cumulative Frequency Distribution Functions for Rating Results

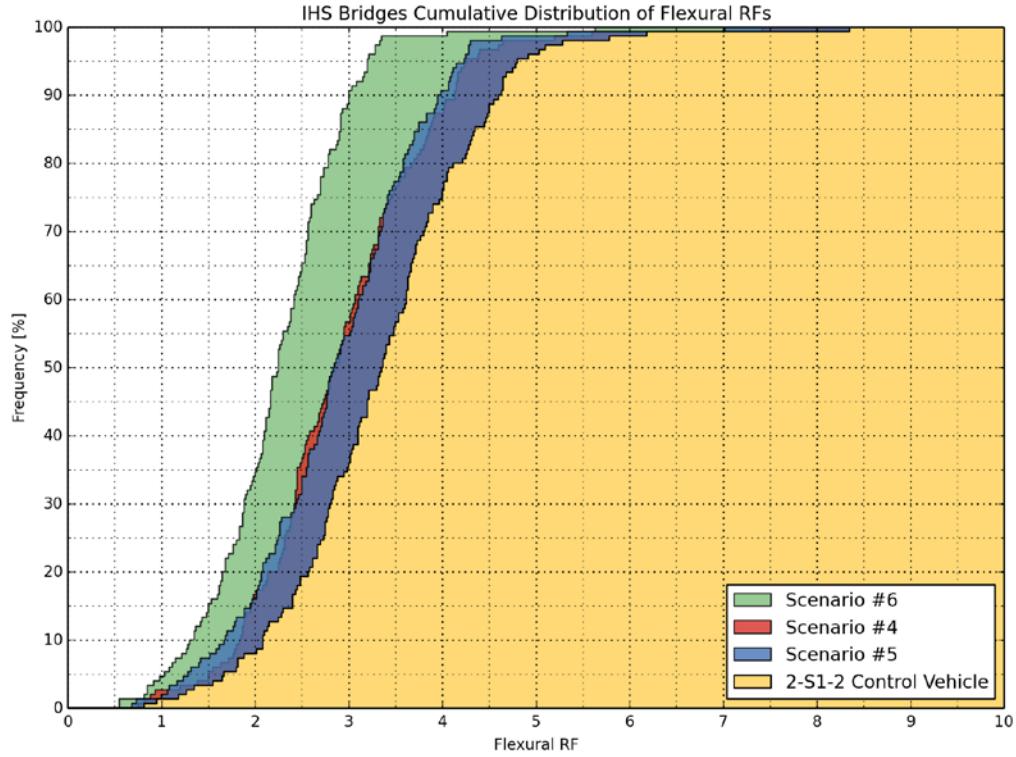
Cumulative frequency distribution functions are helpful in visually determining the percentage of bridges falling below a given rating factor. The cumulative distribution functions for each truck group were constructed for both flexure and shear cases, as shown in **Figure 18** through **Figure 21** for all bridges in the sample database. Separate comparisons for Interstate bridges and other bridges in the NHS are provided in the bridge appendix.

It was observed that Scenarios 1, 2, and 3 result in consistently lower flexure and shear ratings than the 3-S2 control vehicle, where Scenario 1 yields the highest and Scenario 3 yields the lowest RF among the three while Scenario 2 yields RFs in between (**Figure 18** and **Figure 20**).

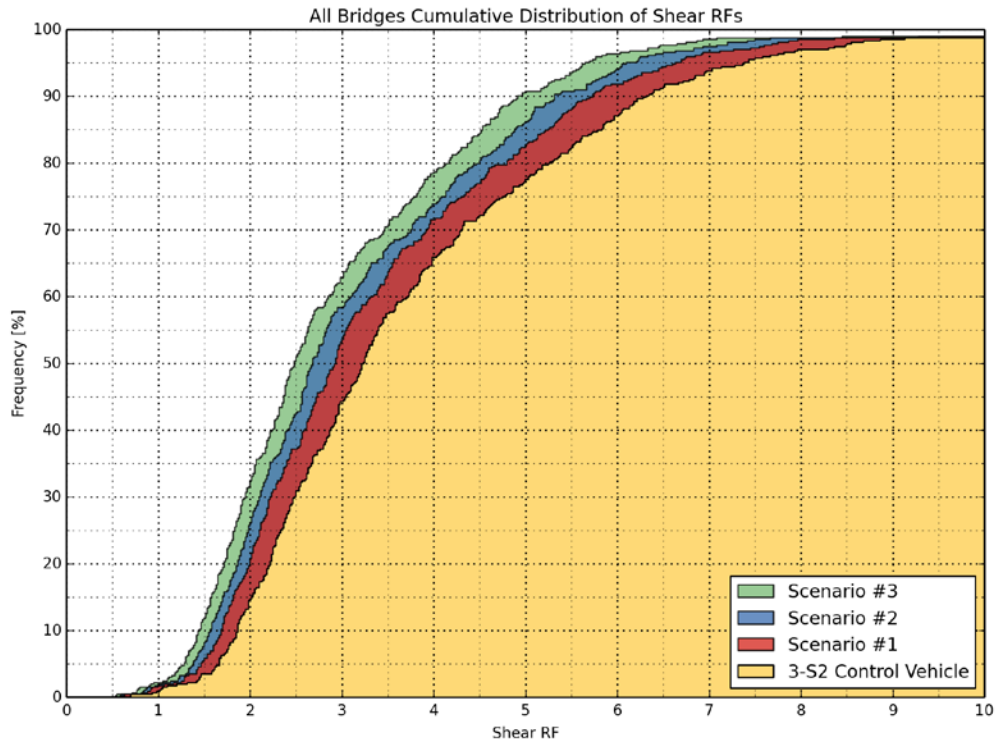
When the 2-S1-2 control vehicle and Scenarios 4, 5, and 6 configurations were compared, similarly to the first group of trucks, it was seen that Scenarios 4, 5 and 6 would result in lower ratings compared to the control vehicle. The configuration with the lowest RFs was found to be Scenario 6. An overlap was observed for Scenarios 4 and 5 when the flexural case was considered, meaning that these scenario vehicles generally yield similar results (**Figure 19** and **Figure 21**).



**Figure 18: Cumulative Distribution of Flexural Rating Factors of All Bridges (3-S2, Scenarios 1-3)**

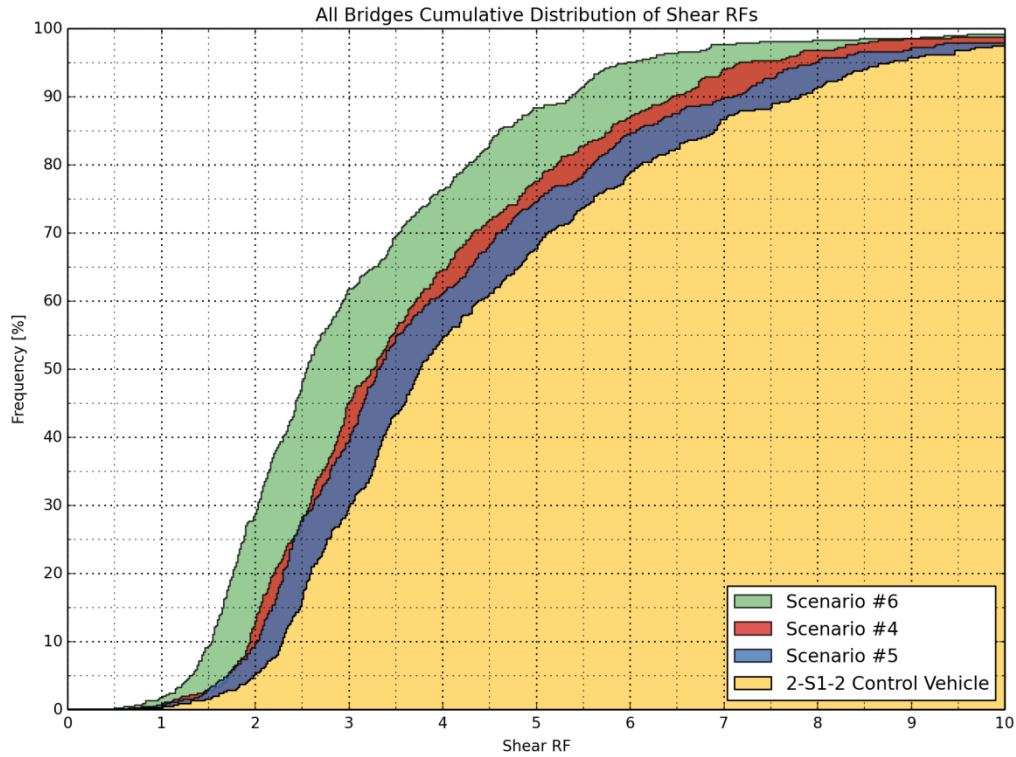


**Figure 19: Cumulative Distribution of Flexural Rating Factors of All Bridges (2-S1-2, Scenarios 4-6)**



**Figure 20: Cumulative Distribution of Shear Rating Factors of All Bridges (3-S2, Scenarios 1-3)**





**Figure 21: Cumulative Distribution of Shear Rating Factors of All Bridges (2-S1-2, Scenarios 4-6)**

***Load Rating Results for All Bridge Types (Normalized Rating Factors)***

The following tables and plots present the normalized load rating results for all bridge types. The normalization was performed by divided the RFs computed for Scenarios 1, 2, and 3 by the RF calculated for the 3-S2 control vehicle. A similar normalization was performed for Scenarios 4, 5, and 6, where the RFs calculated for these configurations were dividing by the RF computed for the 2-S1-2 control vehicle. Tables include the average, maximum and minimum values, as well as the coefficient of variation (COV), which is a measure of relative dispersion in the results. A distribution of normalized RFs for each truck group were constructed for both flexure and shear cases, as shown in **Figure 22** through **Figure 25** for all bridges in the sample database. Separate comparisons for Interstate bridges and other bridges in the NHS are provided in **Appendix C**.

**Table 10: Normalized Flexural Load Rating Results**

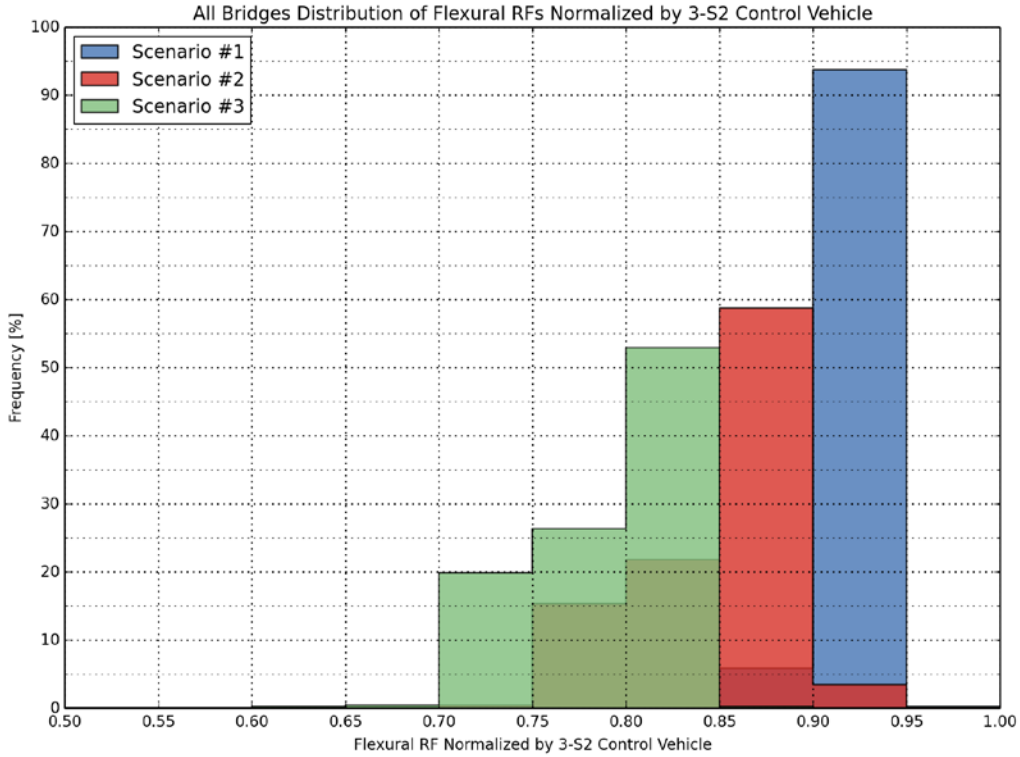
		NORMALIZED BY 3-S2			NORMALIZED BY 2-S1-2		
		Scenario 1	Scenario 2	Scenario 3	Scenario 4	Scenario 5	Scenario 6
ALL BRIDGES	AVERAGE	0.907	0.851	0.790	0.854	0.868	0.674
	MAX	0.976	1.075	1.008	1.045	0.964	0.874
	MIN	0.725	0.652	0.605	0.530	0.512	0.387
	COV (%)	1.2	5.1	5.3	7.0	8.8	8.3
IS BRIDGES	AVERAGE	0.907	0.851	0.789	0.856	0.864	0.676
	MAX	0.976	0.986	0.911	1.045	0.944	0.802
	MIN	0.884	0.743	0.686	0.695	0.572	0.465
	COV (%)	0.9	4.7	4.9	7.3	8.8	8.2
OTHER BRIDGES ON THE NHS	AVERAGE	0.907	0.851	0.790	0.853	0.871	0.674
	MAX	0.923	1.075	1.008	0.956	0.964	0.874
	MIN	0.725	0.652	0.605	0.530	0.512	0.387
	COV (%)	1.3	5.3	5.5	6.9	8.8	8.3

Note: GFB systems and trusses not included.

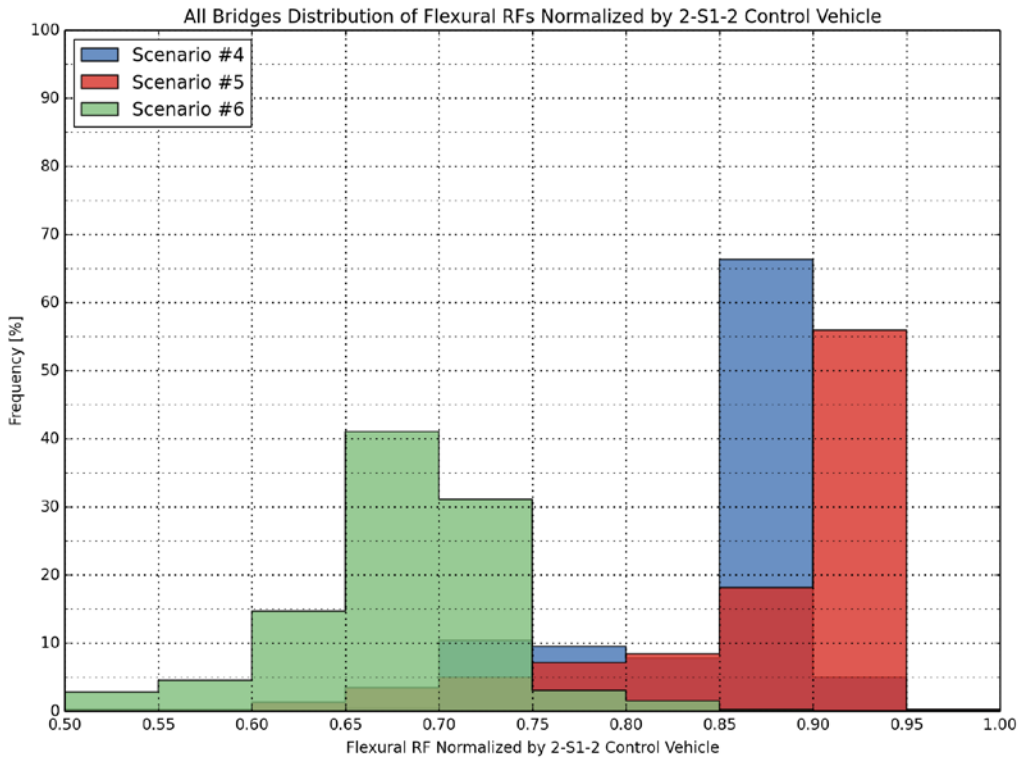
**Table 11: Normalized Shear Load Rating Results**

		NORMALIZED BY 3-S2			NORMALIZED BY 2-S1-2		
		Scenario 1	Scenario 2	Scenario 3	Scenario 4	Scenario 5	Scenario 6
ALL BRIDGES	AVERAGE	0.901	0.846	0.782	0.848	0.882	0.678
	MAX	0.924	1.075	1.008	0.912	0.986	0.844
	MIN	0.789	0.719	0.596	0.688	0.699	0.512
	COV (%)	1.3	4.1	4.3	5.4	6.6	6.4
IS BRIDGES	AVERAGE	0.900	0.843	0.779	0.849	0.877	0.676
	MAX	0.924	0.986	0.911	0.912	0.954	0.799
	MIN	0.789	0.719	0.596	0.726	0.717	0.512
	COV (%)	1.6	3.9	4.2	5.7	6.4	7.2
OTHER BRIDGES ON THE NHS	AVERAGE	0.902	0.847	0.784	0.847	0.885	0.679
	MAX	0.922	1.075	1.008	0.909	0.986	0.844
	MIN	0.868	0.770	0.706	0.688	0.699	0.575
	COV (%)	1.2	4.2	4.4	5.2	6.8	6.0

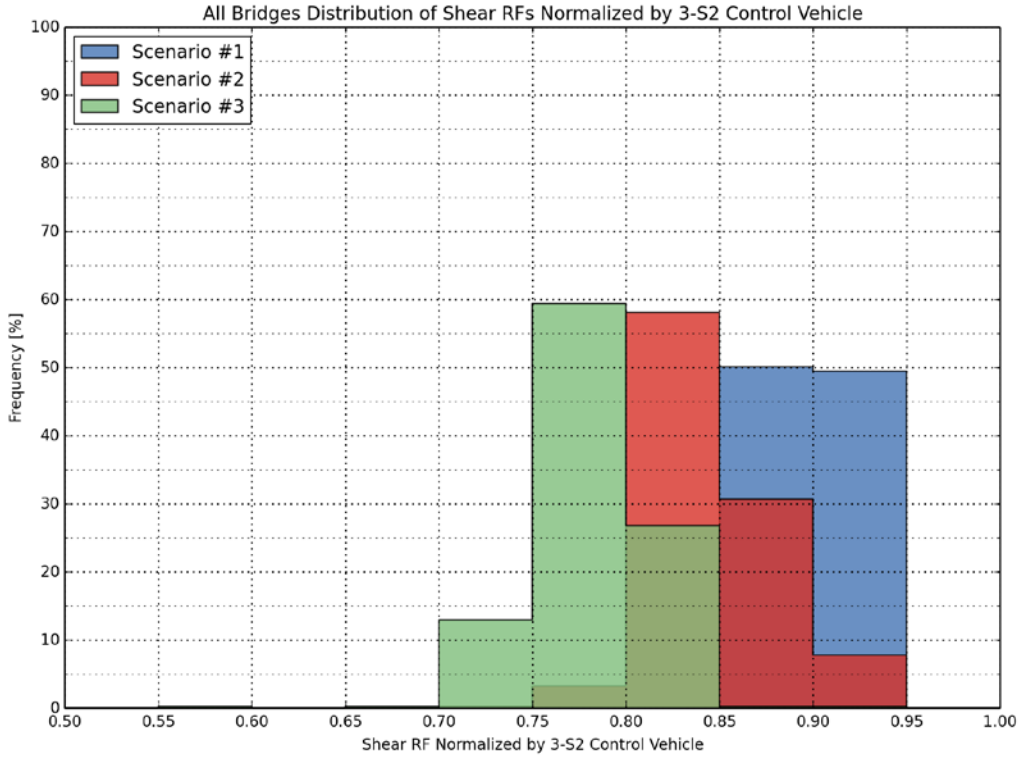
Note: GFB systems and trusses not included.



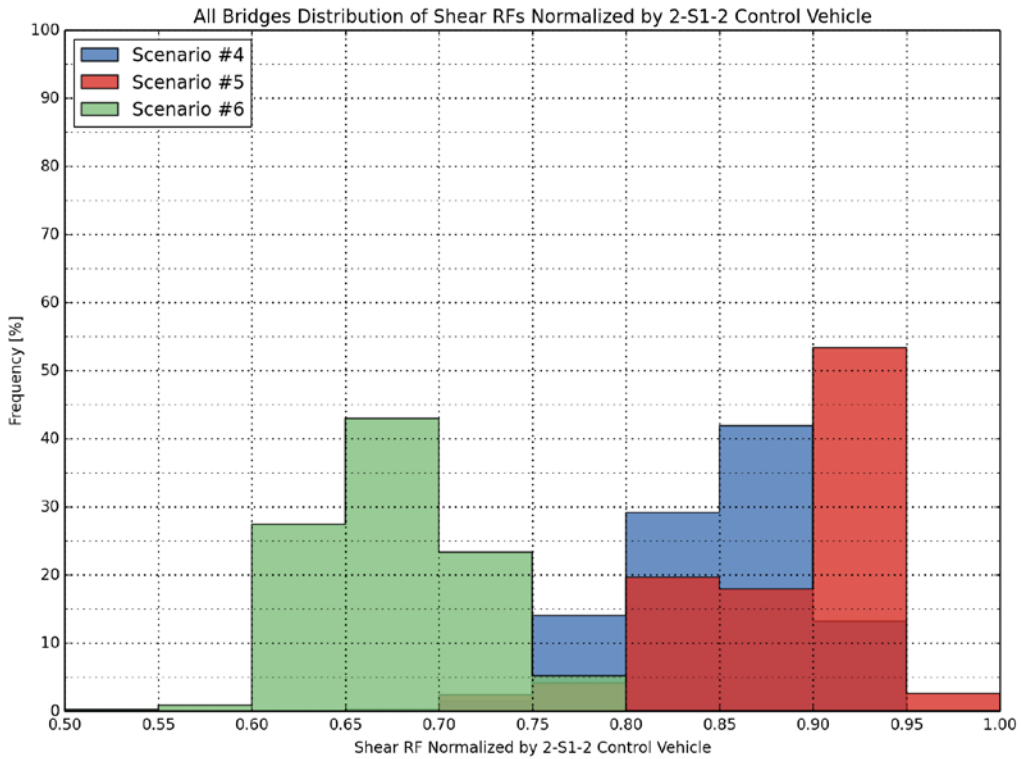
**Figure 22: Distribution of Normalized Flexural Rating Factors for All Bridges (3-S2, Scenario 1, 2 and 3)**



**Figure 23: Distribution of Normalized Flexural Rating Factors for All Bridges (2-S1-2, Scenario 4, 5 and 6)**



**Figure 24: Distribution of Normalized Shear Rating Factors for All Bridges (3-S2, Scenario 1, 2 And 3)**



**Figure 25: Distribution of Normalized Shear Rating Factors for All Bridges (2-S1-2, Scenario 4, 5 and 6)**

### ***Load Rating Results for Bridge Types***

Detailed load rating results based on raw rating factors and normalized rating factors for each bridge type analyzed in this study are tabulated in **Appendix C** of this report.

## **2.4 Posting Analysis**

### ***Summary***

In order to investigate the effect of using alternate truck configurations on load posting, the sample database was filtered for bridges with rating factors less than 1.0. Secondly, the filtered database was sorted primarily by bridge type, and also by span length and by built year.

In 2011, the FHWA National Bridge Inventory included 43,528 bridges on the National Highway System (NHS); 45,417 of these bridges are located on the Interstate System. In 2014, 1,242 bridges that were posted on the NHS with 236 of these posted bridges located on the Interstate System. These posting are based on data reported to FHWA by the states in their submission of annual National Bridge Inventory data. It should be noted, criteria and policies applied to the posting of bridges varies from state to state. Analysis in this area of the Study focused on estimating the number of bridges that would be posted associated with each of the scenarios assessed. The costs to strengthen or replace bridges unable to accommodate scenario vehicles were also estimated. Based on the derived rating factors for each of the alternative truck configurations in each scenario, an assessment was made on the number of bridges that had posting issues and would potentially require either strengthening or replacement. A threshold Rating Factor (RF) value of 1.0 establishes a potential need for bridge strengthening or replacement. **Table 12** shows the projected number of posted bridges associated with each scenario assessed in the Study.

For each bridge type, the number of bridges having a rating factor less than 1.0 was extracted for all alternate configurations (Scenarios 1 to 6). This was performed for Interstate bridges and for other bridges on the NHS, separately. Next, the percentage of bridges that need to be posted for each bridge type, by each truck, was calculated by dividing the number of bridges with a RF less than 1.0 by the total number of bridges in that category in the sample database. Resulting percentages are given in **Table 13**.

In order to project the number of bridges that may need posting in the entire NHS inventory, the actual number of bridges in the NHS inventory for each bridge type was determined. The projected number of bridges to be posted in each category was calculated by multiplying the percentage of posted bridges in the sample database for a given bridge type (computed in **Table 13**) by the actual number of bridges of the same type in the NHS inventory. The projected number of bridges on the NHS inventory that may require load posting is given in detail in **Table 14**, separately for Interstate bridges and for other bridges on the NHS, for each vehicle type. Summary results are listed in **Table 12**.

**Table 12: Projected Number of Posted Bridges for the Entire NHS Inventory**

NUMBER OF BRIDGES IN THE NBI		LOAD RATING RESULTS					PROJECTED NUMBER OF BRIDGES THAT MAY REQUIRE POSTING FOR ENTIRE INVENTORY	
# of IS Bridges in the NBI	# of Other NHS Bridges in the NBI	# of IS Bridges Rated	# of Other NHS Bridges Rated	Vehicle Configuration	IS Bridges Rated w/ RF < 1.0 (%)	Other NHS Bridges Rated w/ RF < 1.0 (%)	# of IS Bridges To Be Posted	# of Other NHS Bridges To Be Posted
45417	43528	153	337	Scenario 1	3.3%	5.0%	1485	2194
				Scenario 2	3.3%	7.7%	1485	3360
				Scenario 3	4.6%	9.5%	2080	4135
				Scenario 4	2.6%	3.0%	1185	1293
				Scenario 5	2.0%	0.9%	890	387
				Scenario 6	6.5%	5.6%	2970	2455

The effect of the alternative truck configurations on the rating results is more pronounced in the “other NHS bridges” category (Highway Network 2) due to the larger sample space.

In addition, the filtered database of bridges with RFs less than 1.0 was sorted by span lengths, using 20 ft. increments, as listed in **Table 15**. The percentage of bridges that need to be posted for each span length interval was calculated in a similar manner to that which was performed for bridge types.

Lastly, the filtered database of bridges with RFs less than 1.0 was sorted by year built, using 10 year intervals, as listed in **Table 16**. The percentage of bridges that need to be posted for each 10 year interval was calculated in a similar manner to that which was performed for bridge types.

**Table 13: Bridges with RF < 1.0 Sorted by Bridge Type**

	Bridge Type	# of IS Bridges Rated	# of Other NHS Bridges Rated	Vehicle Configuration	RF < 1.0 Flexure Controls	RF < 1.0 Shear Controls	Flex or Shear RF < 1.0	# of IS Bridges w/ RF < 1.0	# of Other NHS Bridges w/ RF < 1.0	IS Bridges Rated w/ RF < 1.0 (%)	Other NHS Bridges Rated w/ RF < 1.0 (%)
1	Concrete Slab	18	40	3-S2	4	0	4	2	2	11.1	5.0
		18	40	Scenario 1	5	0	5	2	3	11.1	7.5
		18	40	Scenario 2	8	0	8	2	6	11.1	15.0
		18	40	Scenario 3	10	0	10	2	8	11.1	20.0
		18	40	2-S1-2	0	0	0	0	0	0.0	0.0
		18	40	Scenario 4	3	0	3	2	1	11.1	2.5
		18	40	Scenario 5	0	0	0	0	0	0.0	0.0
2	Concrete Girder / Simple span	30	39	3-S2	1	0	1	1	0	3.3	0.0
		30	39	Scenario 1	1	0	1	1	0	3.3	0.0
		30	39	Scenario 2	1	0	1	1	0	3.3	0.0
		30	39	Scenario 3	2	0	2	2	0	6.7	0.0
		30	39	2-S1-2	1	0	1	1	0	3.3	0.0
		30	39	Scenario 4	1	0	1	1	0	3.3	0.0
		30	39	Scenario 5	1	0	1	1	0	3.3	0.0
3	Concrete Girder / Cont. spans	16	32	3-S2	1	0	1	1	0	6.3	0.0
		16	32	Scenario 1	1	0	1	1	0	6.3	0.0
		16	32	Scenario 2	2	0	2	1	1	6.3	3.1
		16	32	Scenario 3	2	0	2	1	1	6.3	3.1
		16	32	2-S1-2	1	0	1	1	0	6.3	0.0
		16	32	Scenario 4	2	0	2	1	1	6.3	3.1
		16	32	Scenario 5	2	0	2	1	1	6.3	3.1
4	Steel Girder / Simple span, L < 100	14	38	3-S2	2	0	2	0	2	0.0	5.3
		14	38	Scenario 1	2	0	2	0	2	0.0	5.3
		14	38	Scenario 2	4	0	4	0	4	0.0	10.5
		14	38	Scenario 3	4	0	4	0	4	0.0	10.5
		14	38	2-S1-2	0	0	0	0	0	0.0	0.0
		14	38	Scenario 4	2	0	2	0	2	0.0	5.3
		14	38	Scenario 5	0	0	0	0	0	0.0	0.0
		14	38	Scenario 6	2	0	2	0	2	0.0	5.3

**Table 13: Bridges with RF < 1.0 Sorted by Bridge Type (continued)**

	Bridge Type	# of IS Bridges Rated	# of Other NHS Bridges Rated	Vehicle Configuration	RF < 1.0 Flexure Controls	RF < 1.0 Shear Controls	Flex or Shear RF < 1.0	# of IS Bridges w/ RF < 1.0	# of Other NHS Bridges w/ RF < 1.0	IS Bridges Rated w/ RF < 1.0 (%)	Other NHS Bridges Rated w/ RF < 1.0 (%)
5	Steel Girder / Simple span, L > 100	19	17	3-S2	0	2	2	1	1	5.3	5.9
		19	17	Scenario 1	0	2	2	1	1	5.3	5.9
		19	17	Scenario 2	0	2	2	1	1	5.3	5.9
		19	17	Scenario 3	0	2	2	1	1	5.3	5.9
		19	17	2-S1-2	0	1	1	0	1	0.0	5.9
		19	17	Scenario 4	0	1	1	0	1	0.0	5.9
		19	17	Scenario 5	0	2	2	1	1	5.3	5.9
		19	17	Scenario 6	2	2	4	2	2	10.5	11.8
6	Steel Girder / Cont. spans, L < 100	21	28	3-S2	0	0	0	0	0	0.0	0.0
		21	28	Scenario 1	0	0	0	0	0	0.0	0.0
		21	28	Scenario 2	0	0	0	0	0	0.0	0.0
		21	28	Scenario 3	1	0	1	0	1	0.0	3.6
		21	28	2-S1-2	0	0	0	0	0	0.0	0.0
		21	28	Scenario 4	0	0	0	0	0	0.0	0.0
		21	28	Scenario 5	0	0	0	0	0	0.0	0.0
		21	28	Scenario 6	1	0	1	0	1	0.0	3.6
7	Steel Girder / Cont. spans, L > 100	11	33	3-S2	0	0	0	0	0	0.0	0.0
		11	33	Scenario 1	0	0	0	0	0	0.0	0.0
		11	33	Scenario 2	0	0	0	0	0	0.0	0.0
		11	33	Scenario 3	0	0	0	0	0	0.0	0.0
		11	33	2-S1-2	0	0	0	0	0	0.0	0.0
		11	33	Scenario 4	0	0	0	0	0	0.0	0.0
		11	33	Scenario 5	0	0	0	0	0	0.0	0.0
		11	33	Scenario 6	1	0	1	1	0	9.1	0.0
8	Steel Girder / Floor-beam*	2	9	3-S2	N/A	N/A	0	0	0	0.0	0.0
		2	9	Scenario 1	N/A	N/A	0	0	0	0.0	0.0
		2	9	Scenario 2	N/A	N/A	0	0	0	0.0	0.0
		2	9	Scenario 3	N/A	N/A	0	0	0	0.0	0.0
		2	9	2-S1-2	N/A	N/A	0	0	0	0.0	0.0
		2	9	Scenario 4	N/A	N/A	0	0	0	0.0	0.0
		2	9	Scenario 5	N/A	N/A	0	0	0	0.0	0.0
		2	9	Scenario 6	N/A	N/A	0	0	0	0.0	0.0
9	Conc. Tee beams	11	42	3-S2	4	2	6	0	6	0.0	14.3
		11	42	Scenario 1	7	4	11	0	11	0.0	26.2
		11	42	Scenario 2	9	5	14	0	14	0.0	33.3
		11	42	Scenario 3	11	6	17	1	16	9.1	38.1
		11	42	2-S1-2	0	0	0	0	0	0.0	0.0
		11	42	Scenario 4	4	1	5	0	5	0.0	11.9
		11	42	Scenario 5	0	1	1	0	1	0.0	2.4
		11	42	Scenario 6	7	5	12	1	11	9.1	26.2



**Table 13: Bridges with RF < 1.0 Sorted by Bridge Type (continued)**

	Bridge Type	# of IS Bridges Rated	# of Other NHS Bridges Rated	Vehicle Configuration	RF < 1.0 Flexure Controls	RF < 1.0 Shear Controls	Flex or Shear RF < 1.0	# of IS Bridges w/ RF < 1.0	# of Other NHS Bridges w/ RF < 1.0	IS Bridges Rated w/ RF < 1.0 (%)	Other NHS Bridges Rated w/ RF < 1.0 (%)
10	Conc. Box beams	10	44	3-S2	0	0	0	0	0	0.0	0.0
		10	44	Scenario 1	0	0	0	0	0	0.0	0.0
		10	44	Scenario 2	0	0	0	0	0	0.0	0.0
		10	44	Scenario 3	1	0	1	0	1	0.0	2.3
		10	44	2-S1-2	0	0	0	0	0	0.0	0.0
		10	44	Scenario 4	0	0	0	0	0	0.0	0.0
		10	44	Scenario 5	0	0	0	0	0	0.0	0.0
		10	44	Scenario 6	0	0	0	0	0	0.0	0.0
11	Steel Through truss*	1	15	3-S2	Axial	Axial	0	0	0	0.0	0.0
		1	15	Scenario 1	Axial	Axial	0	0	0	0.0	0.0
		1	15	Scenario 2	Axial	Axial	0	0	0	0.0	0.0
		1	15	Scenario 3	Axial	Axial	0	0	0	0.0	0.0
		1	15	2-S1-2	Axial	Axial	0	0	0	0.0	0.0
		1	15	Scenario 4	Axial	Axial	0	0	0	0.0	0.0
		1	15	Scenario 5	Axial	Axial	0	0	0	0.0	0.0
		1	15	Scenario 6	Axial	Axial	0	0	0	0.0	0.0
<b>TOTAL</b>		<b>153</b>	<b>337</b>	3-S2			<b>16</b>	<b>5</b>	<b>11</b>	<b>3.3</b>	<b>3.3</b>
		<b>153</b>	<b>337</b>	Scenario 1			<b>22</b>	<b>5</b>	<b>17</b>	<b>3.3</b>	<b>5.0</b>
		<b>153</b>	<b>337</b>	Scenario 2			<b>31</b>	<b>5</b>	<b>26</b>	<b>3.3</b>	<b>7.7</b>
		<b>153</b>	<b>337</b>	Scenario 3			<b>39</b>	<b>7</b>	<b>32</b>	<b>4.6</b>	<b>9.5</b>
		<b>153</b>	<b>337</b>	2-S1-2			<b>3</b>	<b>2</b>	<b>1</b>	<b>1.3</b>	<b>0.3</b>
		<b>153</b>	<b>337</b>	Scenario 4			<b>14</b>	<b>4</b>	<b>10</b>	<b>2.6</b>	<b>3.0</b>
		<b>153</b>	<b>337</b>	Scenario 5			<b>6</b>	<b>3</b>	<b>3</b>	<b>2.0</b>	<b>0.9</b>
		<b>153</b>	<b>337</b>	Scenario 6			<b>29</b>	<b>10</b>	<b>19</b>	<b>6.5</b>	<b>5.6</b>

N/A: Not applicable.

\*: Girder-floor-beam systems and through trusses were rated using the Load Factor Rating (LFR) methodology. All other bridge types were rated using the Load and Resistance Factor Rating (LRFR) methodology.

**Table 14: Posting Projections**

		LOAD RATING RESULTS					PROJECTED NUMBER OF POSTED BRIDGES FOR ENTIRE INVENTORY	
	Bridge Type	# of IS Bridges Rated	# of Other NHS Bridges Rated	Vehicle Configuration	IS Bridges Rated w/ RF < 1.0 (%)	Other NHS Bridges Rated w/ RF < 1.0 (%)	# of IS Bridges To Be Posted	# of Other NHS Bridges To Be Posted
1	Concrete Slab	18	40	Scenario 1	11.1	7.5	566	368
		18	40	Scenario 2	11.1	15.0	566	735
		18	40	Scenario 3	11.1	20.0	566	981
		18	40	Scenario 4	11.1	2.5	566	123
		18	40	Scenario 5	0.0	0.0	0	0
		18	40	Scenario 6	11.1	5.0	566	245
2	Concrete Girder / Simple span	30	39	Scenario 1	3.3	0.0	310	0
		30	39	Scenario 2	3.3	0.0	310	0
		30	39	Scenario 3	6.7	0.0	629	0
		30	39	Scenario 4	3.3	0.0	310	0
		30	39	Scenario 5	3.3	0.0	310	0
		30	39	Scenario 6	6.7	0.0	629	0
3	Concrete Girder / Cont. spans	16	32	Scenario 1	6.3	0.0	134	0
		16	32	Scenario 2	6.3	3.1	134	118
		16	32	Scenario 3	6.3	3.1	134	118
		16	32	Scenario 4	6.3	3.1	134	118
		16	32	Scenario 5	6.3	3.1	134	118
		16	32	Scenario 6	12.5	3.1	266	118
4	Steel Girder / Simple span, L < 100	14	38	Scenario 1	0.0	5.3	0	275
		14	38	Scenario 2	0.0	10.5	0	545
		14	38	Scenario 3	0.0	10.5	0	545
		14	38	Scenario 4	0.0	5.3	0	275
		14	38	Scenario 5	0.0	0.0	0	0
		14	38	Scenario 6	0.0	5.3	0	275

**Table 14: Posting Projections (continued)**

		PROJECTED NUMBER OF POSTED BRIDGES FOR ENTIRE INVENTORY						
	Bridge Type	# of IS Bridges Rated	# of Other NHS Bridges Rated	Vehicle Configuration	IS Bridges Rated w/ RF < 1.0 (%)	Other NHS Bridges Rated w/ RF < 1.0 (%)	# of IS Bridges To Be Posted	# of Other NHS Bridges To Be Posted
5	Steel Girder / Simple span, L > 100	19	17	Scenario 1	5.3	5.9	151	117
		19	17	Scenario 2	5.3	5.9	151	117
		19	17	Scenario 3	5.3	5.9	151	117
		19	17	Scenario 4	0.0	5.9	0	117
		19	17	Scenario 5	5.3	5.9	151	117
		19	17	Scenario 6	10.5	11.8	299	234
6	Steel Girder / Cont. spans, L < 100	21	28	Scenario 1	0.0	0.0	0	0
		21	28	Scenario 2	0.0	0.0	0	0
		21	28	Scenario 3	0.0	3.6	0	142
		21	28	Scenario 4	0.0	0.0	0	0
		21	28	Scenario 5	0.0	0.0	0	0
		21	28	Scenario 6	0.0	3.6	0	142
7	Steel Girder / Cont. spans, L > 100	11	33	Scenario 1	0.0	0.0	0	0
		11	33	Scenario 2	0.0	0.0	0	0
		11	33	Scenario 3	0.0	0.0	0	0
		11	33	Scenario 4	0.0	0.0	0	0
		11	33	Scenario 5	0.0	0.0	0	0
		11	33	Scenario 6	9.1	0.0	387	0
8	Steel Girder / Floor-beam*	2	9	Scenario 1	0.0	0.0	0	0
		2	9	Scenario 2	0.0	0.0	0	0
		2	9	Scenario 3	0.0	0.0	0	0
		2	9	Scenario 4	0.0	0.0	0	0
		2	9	Scenario 5	0.0	0.0	0	0
		2	9	Scenario 6	0.0	0.0	0	0

**Table 14: Posting Projections (continued)**

		LOAD RATING RESULTS					PROJECTED NUMBER OF POSTED BRIDGES FOR ENTIRE INVENTORY	
	Bridge Type	# of IS Bridges Rated	# of Other NHS Bridges Rated	Vehicle Configuration	IS Bridges Rated w/ RF < 1.0 (%)	Other NHS Bridges Rated w/ RF < 1.0 (%)	# of IS Bridges To Be Posted	# of Other NHS Bridges To Be Posted
9	Conc. Tee beams	11	42	Scenario 1	0.0	26.2	0	917
		11	42	Scenario 2	0.0	33.3	0	1165
		11	42	Scenario 3	9.1	38.1	240	1333
		11	42	Scenario 4	0.0	11.9	0	416
		11	42	Scenario 5	0.0	2.4	0	84
		11	42	Scenario 6	9.1	26.2	240	917
10	Conc. Box beams	10	44	Scenario 1	0.0	0.0	0	0
		10	44	Scenario 2	0.0	0.0	0	0
		10	44	Scenario 3	0.0	2.3	0	117
		10	44	Scenario 4	0.0	0.0	0	0
		10	44	Scenario 5	0.0	0.0	0	0
		10	44	Scenario 6	0.0	0.0	0	0
11	Steel Through Truss*	1	15	Scenario 1	0.0	0.0	0	0
		1	15	Scenario 2	0.0	0.0	0	0
		1	15	Scenario 3	0.0	0.0	0	0
		1	15	Scenario 4	0.0	0.0	0	0
		1	15	Scenario 5	0.0	0.0	0	0
		1	15	Scenario 6	0.0	0.0	0	0
<b>Total</b>		<b>153</b>	<b>337</b>	Scenario 1	<b>3.3</b>	<b>5.0</b>	1485	2194
		<b>153</b>	<b>337</b>	Scenario 2	<b>3.3</b>	<b>7.7</b>	1485	3360
		<b>153</b>	<b>337</b>	Scenario 3	<b>4.6</b>	<b>9.5</b>	2080	4135
		<b>153</b>	<b>337</b>	Scenario 4	<b>2.6</b>	<b>3.0</b>	1185	1293
		<b>153</b>	<b>337</b>	Scenario 5	<b>2.0</b>	<b>0.9</b>	890	387
		<b>153</b>	<b>337</b>	Scenario 6	<b>6.5</b>	<b>5.6</b>	2970	2455

\*: Girder-floor-beam systems and through trusses were rated using the Load Factor Rating (LFR) methodology. All other bridge types were rated using the Load and Resistance Factor Rating (LRFR) methodology.

**Table 15: Bridges with RF < 1.0 Sorted by Span Length**

Span Length [ft.]	# of IS Bridges Rated	# of Other NHS Bridges Rated	Vehicle Configuration	# of IS Bridges w/ RF < 1.0	# of Other NHS Bridges w/ RF < 1.0	IS Bridges Rated w/ RF < 1.0 (%)	Other NHS Bridges Rated w/ RF < 1.0 (%)
<20	0	8	Scenario 1	0	0	0.0	0.0
	0	8	Scenario 2	0	1	0.0	12.5
	0	8	Scenario 3	0	1	0.0	12.5
	0	8	Scenario 4	0	0	0.0	0.0
	0	8	Scenario 5	0	0	0.0	0.0
	0	8	Scenario 6	0	0	0.0	0.0
20-40	24	67	Scenario 1	2	10	8.3	14.9
	24	67	Scenario 2	2	13	8.3	19.4
	24	67	Scenario 3	2	16	8.3	23.9
	24	67	Scenario 4	2	5	8.3	7.5
	24	67	Scenario 5	0	0	0.0	0.0
	24	67	Scenario 6	2	6	8.3	9.0
40-60	25	76	Scenario 1	1	5	4.0	6.6
	25	76	Scenario 2	1	8	4.0	10.5
	25	76	Scenario 3	2	10	8.0	13.2
	25	76	Scenario 4	1	2	4.0	2.6
	25	76	Scenario 5	1	1	4.0	1.3
	25	76	Scenario 6	1	7	4.0	9.2
60-80	31	59	Scenario 1	1	1	3.2	1.7
	31	59	Scenario 2	1	2	3.2	3.4
	31	59	Scenario 3	2	2	6.5	3.4
	31	59	Scenario 4	1	2	3.2	3.4
	31	59	Scenario 5	1	1	3.2	1.7
	31	59	Scenario 6	3	2	9.7	3.4
80-100	31	44	Scenario 1	0	0	0.0	0.0
	31	44	Scenario 2	0	1	0.0	2.3
	31	44	Scenario 3	0	2	0.0	4.5
	31	44	Scenario 4	0	0	0.0	0.0
	31	44	Scenario 5	0	0	0.0	0.0
	31	44	Scenario 6	1	2	3.2	4.5

**Table 15: Bridges with RF < 1.0 Sorted by Span Length (continued)**

Span Length [ft.]	# of IS Bridges Rated	# of Other NHS Bridges Rated	Vehicle Configuration	# of IS Bridges w/ RF < 1.0	# of Other NHS Bridges w/ RF < 1.0	IS Bridges Rated w/ RF < 1.0 (%)	Other NHS Bridges Rated w/ RF < 1.0 (%)
100-120	22	32	Scenario 1	1	1	4.5	3.1
	22	32	Scenario 2	1	1	4.5	3.1
	22	32	Scenario 3	1	1	4.5	3.1
	22	32	Scenario 4	0	1	0.0	3.1
	22	32	Scenario 5	1	1	4.5	3.1
	22	32	Scenario 6	1	2	4.5	6.3
120-140	14	11	Scenario 1	0	0	0.0	0.0
	14	11	Scenario 2	0	0	0.0	0.0
	14	11	Scenario 3	0	0	0.0	0.0
	14	11	Scenario 4	0	0	0.0	0.0
	14	11	Scenario 5	0	0	0.0	0.0
	14	11	Scenario 6	0	0	0.0	0.0
140-160	2	10	Scenario 1	0	0	0.0	0.0
	2	10	Scenario 2	0	0	0.0	0.0
	2	10	Scenario 3	0	0	0.0	0.0
	2	10	Scenario 4	0	0	0.0	0.0
	2	10	Scenario 5	0	0	0.0	0.0
	2	10	Scenario 6	0	0	0.0	0.0
160-180	1	6	Scenario 1	0	0	0.0	0.0
	1	6	Scenario 2	0	0	0.0	0.0
	1	6	Scenario 3	0	0	0.0	0.0
	1	6	Scenario 4	0	0	0.0	0.0
	1	6	Scenario 5	0	0	0.0	0.0
	1	6	Scenario 6	1	0	100.0	0.0
180-200	1	1	Scenario 1	0	0	0.0	0.0
	1	1	Scenario 2	0	0	0.0	0.0
	1	1	Scenario 3	0	0	0.0	0.0
	1	1	Scenario 4	0	0	0.0	0.0
	1	1	Scenario 5	0	0	0.0	0.0
	1	1	Scenario 6	1	0	100.0	0.0

**Table 15: Bridges with RF < 1.0 Sorted by Span Length** *(continued)*

Span Length [ft.]	# of IS Bridges Rated	# of Other NHS Bridges Rated	Vehicle Configuration	# of IS Bridges w/ RF < 1.0	# of Other NHS Bridges w/ RF < 1.0	IS Bridges Rated w/ RF < 1.0 (%)	Other NHS Bridges Rated w/ RF < 1.0 (%)
>200	2	23	Scenario 1	0	0	0.0	0.0
	2	23	Scenario 2	0	0	0.0	0.0
	2	23	Scenario 3	0	0	0.0	0.0
	2	23	Scenario 4	0	0	0.0	0.0
	2	23	Scenario 5	0	0	0.0	0.0
	2	23	Scenario 6	0	0	0.0	0.0
Total	153	337	Scenario 1	5	17	3.3	5.0
	153	337	Scenario 2	5	26	3.3	7.7
	153	337	Scenario 3	7	32	4.6	9.5
	153	337	Scenario 4	4	10	2.6	3.0
	153	337	Scenario 5	3	3	2.0	0.9
	153	337	Scenario 6	10	19	6.5	5.6

**Table 16: Bridges with RF < 1.0 Sorted by Year Built**

<b>Year Built</b>	<b># of IS Bridges Rated</b>	<b># of Other NHS Bridges Rated</b>	<b>Vehicle Configuration</b>	<b># of IS Bridges w/ RF &lt; 1.0</b>	<b># of Other NHS Bridges w/ RF &lt; 1.0</b>	<b>IS Bridges Rated w/ RF &lt; 1.0 (%)</b>	<b>Other NHS Bridges Rated w/ RF &lt; 1.0 (%)</b>
<1920	0	2	Scenario 1	0	0	0.0	0.0
	0	2	Scenario 2	0	1	0.0	50.0
	0	2	Scenario 3	0	1	0.0	50.0
	0	2	Scenario 4	0	0	0.0	0.0
	0	2	Scenario 5	0	0	0.0	0.0
	0	2	Scenario 6	0	0	0.0	0.0
1920-1930	0	20	Scenario 1	0	2	0.0	10.0
	0	20	Scenario 2	0	3	0.0	15.0
	0	20	Scenario 3	0	4	0.0	20.0
	0	20	Scenario 4	0	2	0.0	10.0
	0	20	Scenario 5	0	0	0.0	0.0
	0	20	Scenario 6	0	2	0.0	10.0
1930-1940	0	42	Scenario 1	0	6	0.0	14.3
	0	42	Scenario 2	0	9	0.0	21.4
	0	42	Scenario 3	0	10	0.0	23.8
	0	42	Scenario 4	0	3	0.0	7.1
	0	42	Scenario 5	0	0	0.0	0.0
	0	42	Scenario 6	0	6	0.0	14.3
1940-1950	0	21	Scenario 1	0	1	0.0	4.8
	0	21	Scenario 2	0	1	0.0	4.8
	0	21	Scenario 3	0	3	0.0	14.3
	0	21	Scenario 4	0	0	0.0	0.0
	0	21	Scenario 5	0	0	0.0	0.0
	0	21	Scenario 6	0	2	0.0	9.5
1950-1960	21	41	Scenario 1	0	2	0.0	4.9
	21	41	Scenario 2	0	5	0.0	12.2
	21	41	Scenario 3	1	6	4.8	14.6
	21	41	Scenario 4	0	1	0.0	2.4
	21	41	Scenario 5	0	1	0.0	2.4
	21	41	Scenario 6	1	4	4.8	9.8



**Table 16: Bridges with RF < 1.0 Sorted by Year Built** *(continued)*

Year Built	# of IS Bridges Rated	# of Other NHS Bridges Rated	Vehicle Configuration	# of IS Bridges w/ RF < 1.0	# of Other NHS Bridges w/ RF < 1.0	IS Bridges Rated w/ RF < 1.0 (%)	Other NHS Bridges Rated w/ RF < 1.0 (%)
1960-1970	58	45	Scenario 1	4	2	6.9	4.4
	58	45	Scenario 2	4	2	6.9	4.4
	58	45	Scenario 3	4	2	6.9	4.4
	58	45	Scenario 4	3	1	5.2	2.2
	58	45	Scenario 5	2	1	3.4	2.2
	58	45	Scenario 6	5	2	8.6	4.4
1970-1980	35	37	Scenario 1	0	1	0.0	2.7
	35	37	Scenario 2	0	1	0.0	2.7
	35	37	Scenario 3	0	1	0.0	2.7
	35	37	Scenario 4	0	0	0.0	0.0
	35	37	Scenario 5	0	0	0.0	0.0
	35	37	Scenario 6	0	0	0.0	0.0
1980-1990	18	38	Scenario 1	1	1	5.6	2.6
	18	38	Scenario 2	1	2	5.6	5.3
	18	38	Scenario 3	2	3	11.1	7.9
	18	38	Scenario 4	1	2	5.6	5.3
	18	38	Scenario 5	1	1	5.6	2.6
	18	38	Scenario 6	3	1	16.7	2.6
1990-2000	11	40	Scenario 1	0	2	0.0	5.0
	11	40	Scenario 2	0	2	0.0	5.0
	11	40	Scenario 3	0	2	0.0	5.0
	11	40	Scenario 4	0	1	0.0	2.5
	11	40	Scenario 5	0	0	0.0	0.0
	11	40	Scenario 6	0	2	0.0	5.0
>2000	10	51	Scenario 1	0	0	0.0	0.0
	10	51	Scenario 2	0	0	0.0	0.0
	10	51	Scenario 3	0	0	0.0	0.0
	10	51	Scenario 4	0	0	0.0	0.0
	10	51	Scenario 5	0	0	0.0	0.0
	10	51	Scenario 6	1	0	10.0	0.0
<b>Total</b>	<b>153</b>	<b>337</b>	Scenario 1	<b>5</b>	<b>17</b>	<b>3.3</b>	<b>5.0</b>
	<b>153</b>	<b>337</b>	Scenario 2	<b>5</b>	<b>26</b>	<b>3.3</b>	<b>7.7</b>
	<b>153</b>	<b>337</b>	Scenario 3	<b>7</b>	<b>32</b>	<b>4.6</b>	<b>9.5</b>
	<b>153</b>	<b>337</b>	Scenario 4	<b>4</b>	<b>10</b>	<b>2.6</b>	<b>3.0</b>
	<b>153</b>	<b>337</b>	Scenario 5	<b>3</b>	<b>3</b>	<b>2.0</b>	<b>0.9</b>
	<b>153</b>	<b>337</b>	Scenario 6	<b>10</b>	<b>19</b>	<b>6.5</b>	<b>5.6</b>

## **2.5 Load Effects Based On Span Lengths**

In order to investigate the effect of live loads on the rating results, the USDOT study team computed moment and shear load effects for simple and continuous spans for span lengths from 20 ft. to 240 ft. Compared to the actual rating factors, where the resistance of members are also accounted for, this investigation is a more simplistic approach that isolates the live load parameter in the rating factor calculations. Note that load effects are not an indicator of the live load capacity or the safety of the structure under increasing truck weights, since they are not coupled with member resistances. Therefore, the RF comparisons presented earlier provide a more realistic assessment of the bridge performance under alternative truck configuration loads.

**Table 17** and **Table 18** list positive moments and shears for simple spans, whereas **Table 19** lists negative moments for continuous spans. Load effects from the alternative truck configurations were also normalized by the related control vehicle for comparison purposes and listed in **Table 20 to Table 22**.

Load effects from Scenarios 1, 2, and 3 were normalized by load effects from 3-S2 control vehicle, and load effects from Scenarios 4, 5, and 6 were normalized by load effects from the 2-S1-2 control vehicle. Normalized load effects are also illustrated in **Figure 26**, **Figure 28**, and **Figure 30** for the 3-S2 control vehicle as well as Scenarios 1, 2 and 3. **Figure 27**, **Figure 29** and **Figure 31** illustrate the normalized load effects for the 2-S1-2 control vehicle and Scenarios 4, 5, and 6.

**Table 17: Positive Moment Load Effects for Simple Spans**

Span Length [ft.]	Positive Moment Load Effects for Simple Spans [kips -ft.]							
	3-S2	Scenario 1	Scenario 2	Scenario 3	2-S1-2	Scenario 4	Scenario 5	Scenario 6
20	136	151	170	184	85	121	96	115
40	329	363	406	440	228	291	248	352
60	559	612	643	696	470	534	514	710
80	790	862	904	976	800	892	865	1135
100	1147	1263	1297	1397	1153	1292	1301	1664
120	1530	1686	1733	1862	1506	1692	1799	2233
140	1914	2109	2170	2327	1859	2092	2327	2850
160	2311	2540	2607	2792	2212	2492	2854	3494
180	2710	2981	3044	3258	2565	2892	3382	4139
200	3110	3421	3491	3739	2918	3292	3909	4783
220	3509	3862	3946	4223	3271	3692	4437	5428
240	3909	4302	4401	4708	3624	4092	4964	6072

**Table 18: Shear Load Effects for Simple Spans**

Span Length [ft.]	Shear Load Effects for Simple Spans [kips]							
	3-S2	Scenario 1	Scenario 2	Scenario 3	2-S1-2	Scenario 4	Scenario 5	Scenario 6
20	31	34	37	40	22	29	24	28
40	38	42	42	46	30	37	32	44
60	41	45	51	55	39	45	42	55
80	49	55	60	64	43	50	50	66
100	55	61	66	71	48	54	59	75
120	59	66	70	75	52	58	65	82
140	62	69	73	78	55	61	71	87
160	64	71	75	81	57	63	75	91
180	66	73	77	82	58	65	79	95
200	67	75	78	84	59	67	81	98
220	69	76	80	85	60	68	84	101
240	70	77	81	86	61	69	85	103

**Table 19: Negative Moment Load Effects for Continuous Spans**

Span Length [ft.]	Negative Moment Load Effects for Continuous Spans [kips-ft.]							
	3-S2	Scenario 1	Scenario 2	Scenario 3	2-S1-2	Scenario 4	Scenario 5	Scenario 6
20	-85	-92	-86	-93	-60	-73	-68	-100
40	-220	-245	-268	-288	-185	-219	-210	-261
60	-422	-466	-476	-509	-314	-364	-442	-542
80	-550	-605	-609	-650	-428	-492	-638	-800
100	-636	-697	-698	-747	-589	-636	-779	-993
120	-798	-881	-921	-985	-757	-843	-955	-1186
140	-988	-1091	-1135	-1212	-918	-1028	-1216	-1484
160	-1172	-1294	-1344	-1434	-1076	-1209	-1468	-1792
180	-1352	-1492	-1548	-1651	-1231	-1385	-1715	-2091
200	-1530	-1687	-1750	-1865	-1384	-1560	-1955	-2385
220	-1705	-1881	-1948	-2076	-1536	-1732	-2191	-2674
240	-1878	-2072	-2145	-2286	-1687	-1904	-2426	-2960

**Table 20: Normalized Positive Moment Load Effects for Simple Spans**

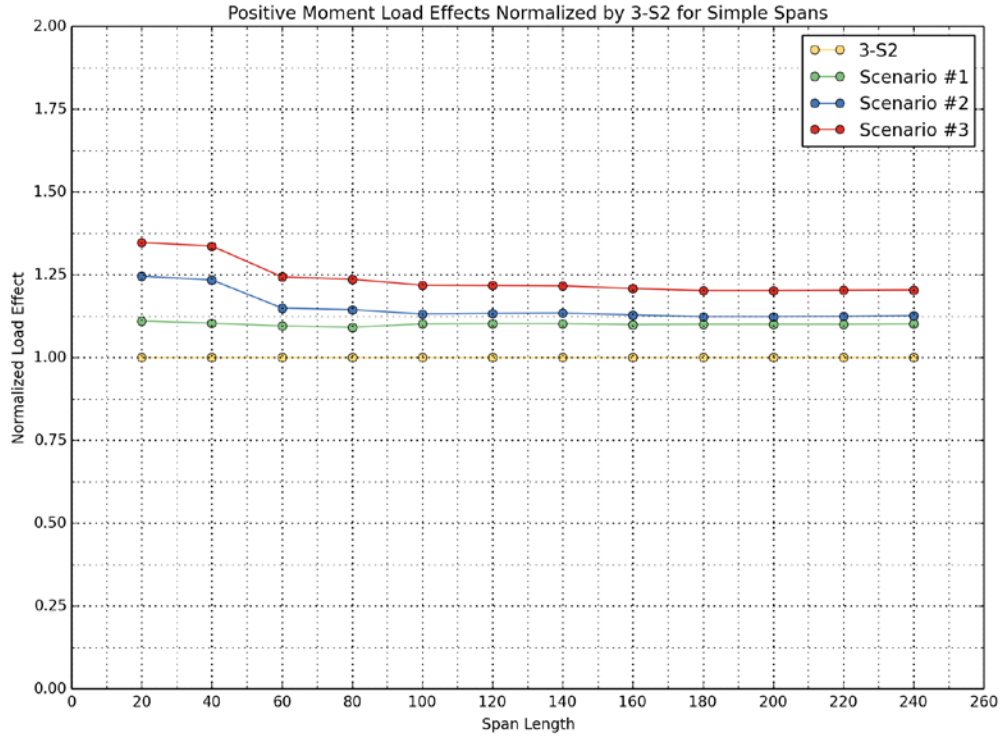
Span Length [ft.]	Normalized Positive Moment Load Effects for Simple Spans					
	Normalized by 3-S2			Normalized by 2-S1-2		
	Scenario 1	Scenario 2	Scenario 3	Scenario 4	Scenario 5	Scenario 6
20	1.110	1.245	1.347	1.429	1.129	1.351
40	1.103	1.234	1.336	1.279	1.090	1.544
60	1.095	1.149	1.243	1.136	1.094	1.510
80	1.091	1.144	1.236	1.116	1.082	1.419
100	1.101	1.131	1.218	1.121	1.129	1.443
120	1.102	1.133	1.217	1.124	1.195	1.483
140	1.102	1.134	1.216	1.126	1.252	1.533
160	1.099	1.128	1.208	1.127	1.291	1.580
180	1.100	1.123	1.202	1.128	1.319	1.614
200	1.100	1.123	1.202	1.128	1.340	1.639
220	1.100	1.124	1.203	1.129	1.357	1.660
240	1.101	1.126	1.204	1.129	1.370	1.676

**Table 21: Normalized Shear Load Effects for Simple Spans**

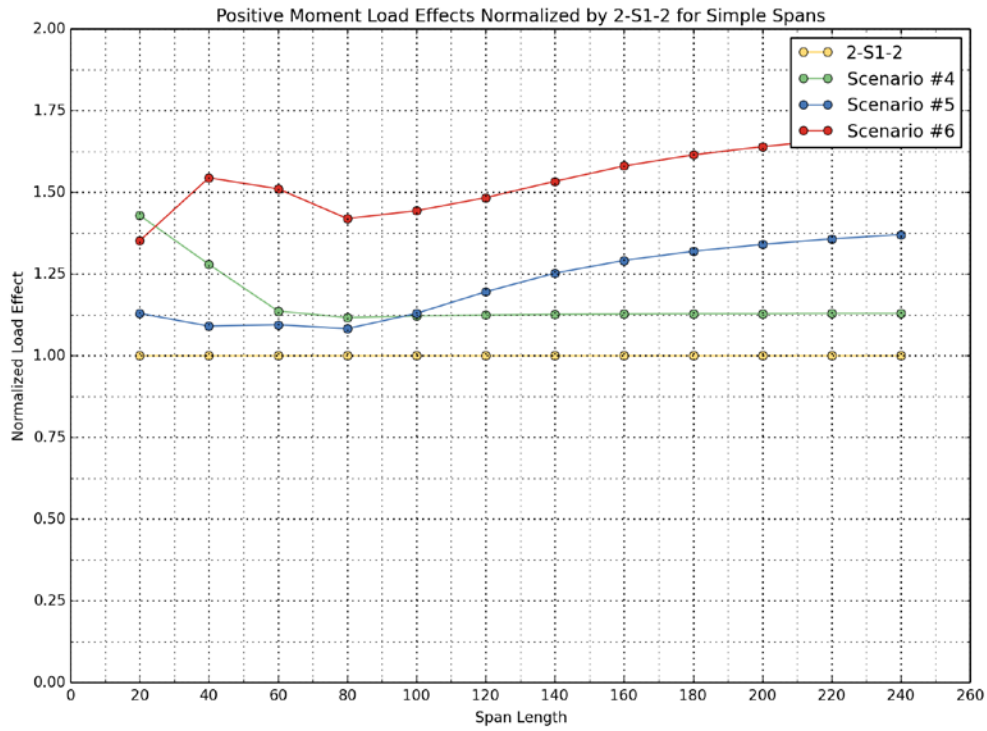
Span Length [ft.]	Normalized Shear Load Effects for Simple Spans					
	Normalized by 3-S2			Normalized by 2-S1-2		
	Scenario 1	Scenario 2	Scenario 3	Scenario 4	Scenario 5	Scenario 6
20	1.110	1.210	1.310	1.304	1.085	1.275
40	1.094	1.105	1.196	1.205	1.064	1.458
60	1.099	1.239	1.338	1.168	1.077	1.424
80	1.119	1.221	1.313	1.149	1.163	1.530
100	1.114	1.197	1.284	1.106	1.216	1.559
120	1.112	1.185	1.268	1.112	1.257	1.582
140	1.110	1.176	1.258	1.116	1.301	1.596
160	1.109	1.170	1.251	1.119	1.331	1.606
180	1.108	1.166	1.246	1.121	1.353	1.631
200	1.107	1.163	1.242	1.122	1.370	1.655
220	1.107	1.161	1.239	1.123	1.383	1.672
240	1.106	1.158	1.236	1.124	1.394	1.687

**Table 22: Normalized Negative Moment Load Effects for Continuous Spans**

Span Length [ft.]	Normalized Negative Moment Load Effects for Simple Spans					
	Normalized by 3-S2			Normalized by 2-S1-2		
	Scenario 1	Scenario 2	Scenario 3	Scenario 4	Scenario 5	Scenario 6
20	1.087	1.011	1.093	1.208	1.123	1.659
40	1.114	1.217	1.309	1.185	1.138	1.412
60	1.104	1.128	1.206	1.158	1.406	1.726
80	1.099	1.107	1.181	1.148	1.489	1.868
100	1.096	1.098	1.176	1.079	1.322	1.685
120	1.105	1.155	1.234	1.114	1.262	1.567
140	1.104	1.149	1.226	1.120	1.325	1.616
160	1.104	1.147	1.223	1.123	1.365	1.665
180	1.104	1.146	1.221	1.126	1.394	1.700
200	1.103	1.144	1.219	1.128	1.413	1.724
220	1.103	1.143	1.218	1.128	1.427	1.742
240	1.103	1.142	1.217	1.128	1.438	1.754



**Figure 26: Normalized Flexural Load Effects for Simple Spans (3-S2, Scenario 1, 2 and 3)**



**Figure 27: Normalized Flexural Load Effects for Simple Spans (2-S1-2, Scenario 4, 5 and 6)**

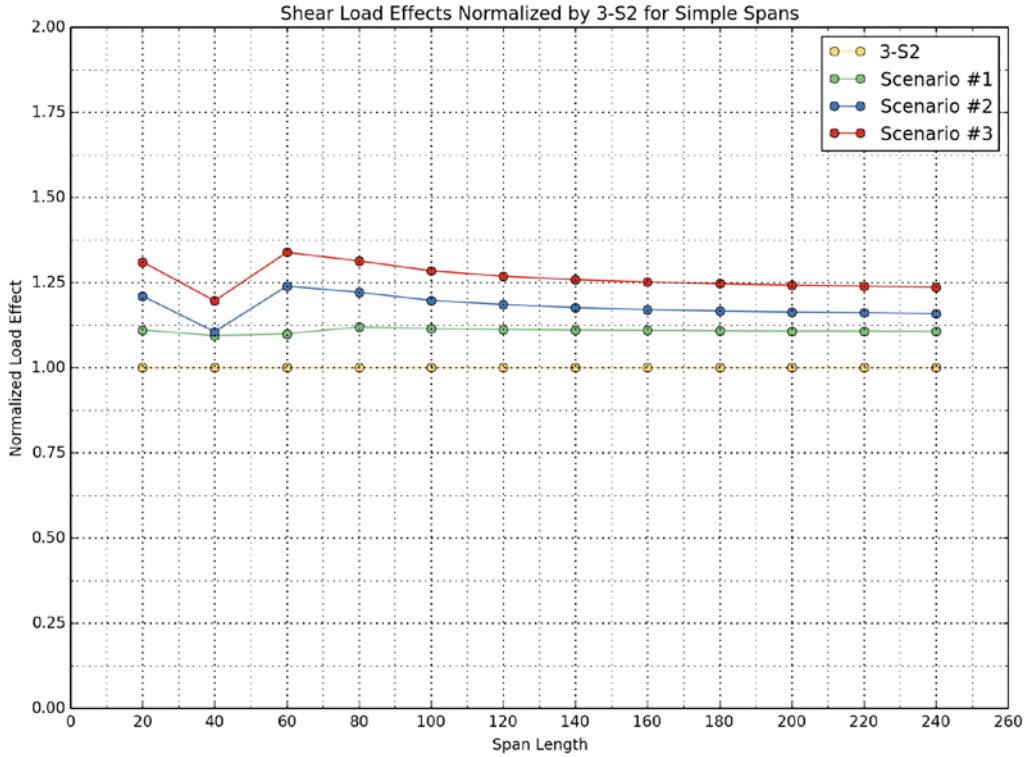


Figure 28: Normalized Shear Load Effects for Simple Spans (3-S2, Scenario 1, 2 and 3)

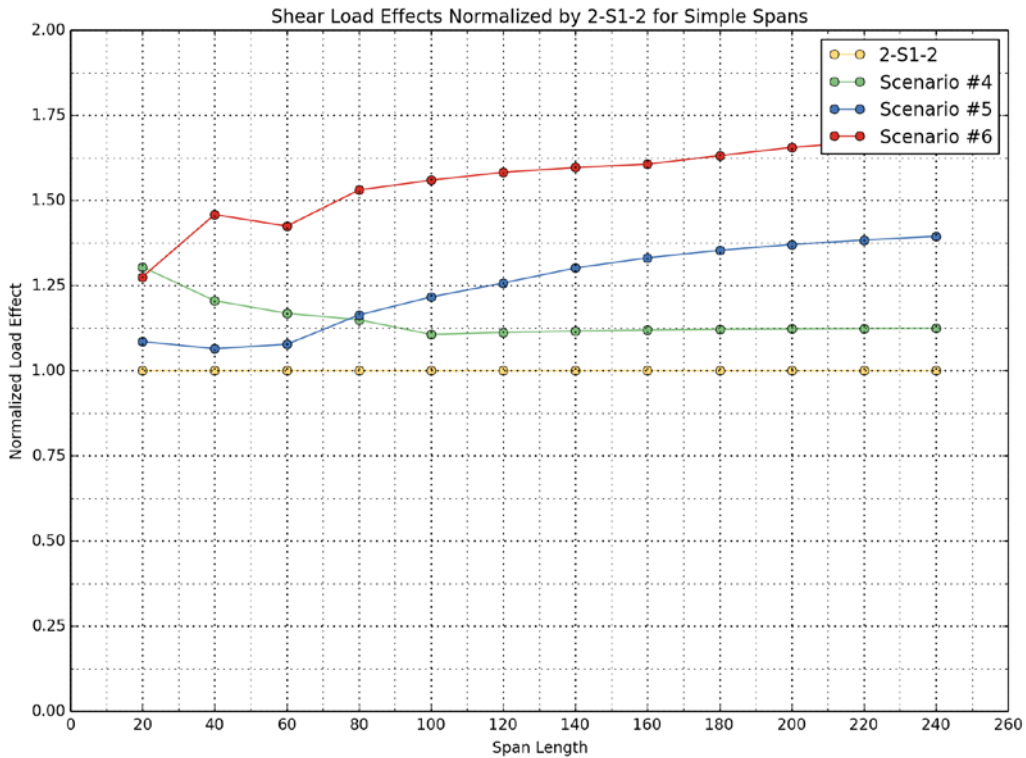
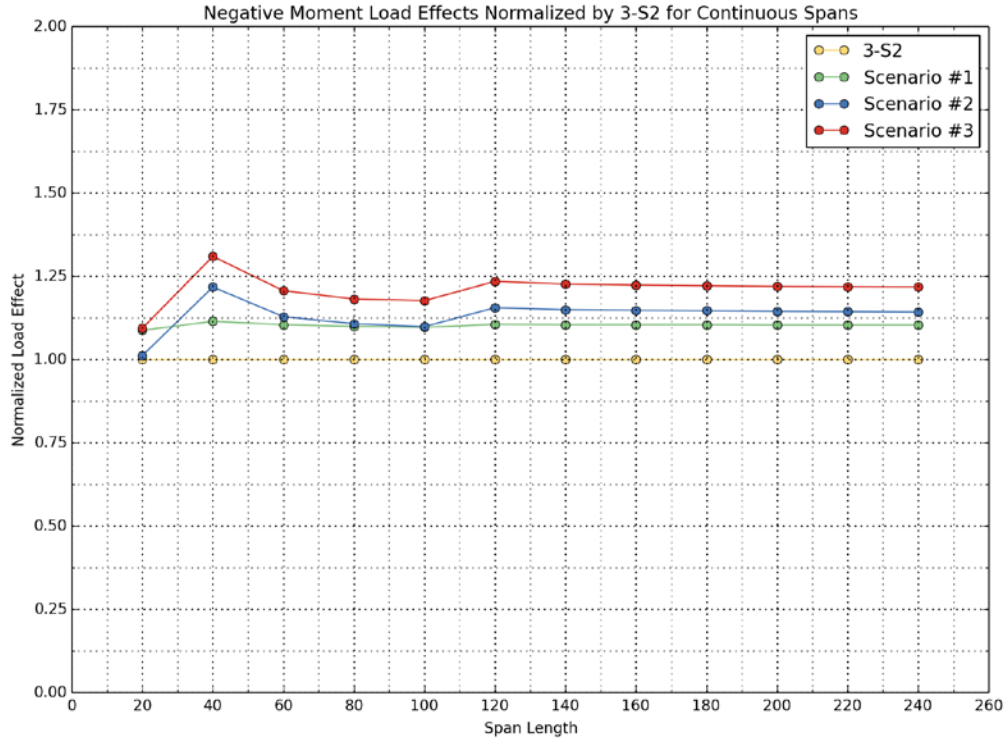
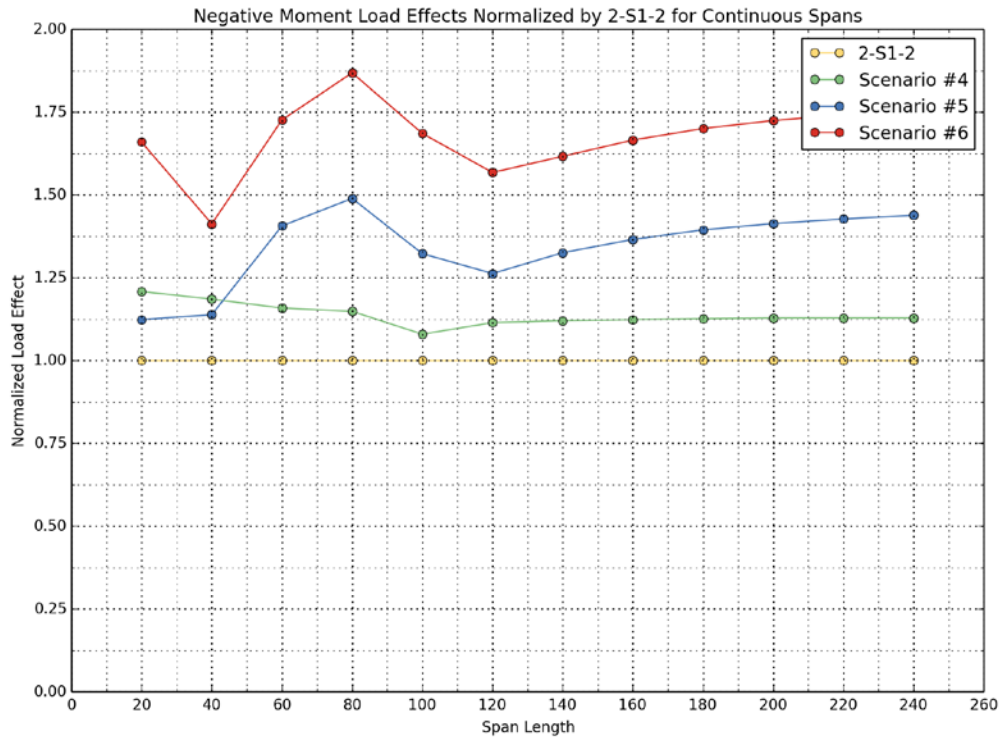


Figure 29: Normalized Shear Load Effects for Simple Spans (2-S1-2, Scenario 4, 5 and 6)



**Figure 30: Normalized Flexural Load Effects for Continuous Spans (3-S2, Scenario 1, 2 and 3)**



**Figure 31: Normalized Flexural Load Effects for Continuous Spans (2-S1-2, Scenario 4, 5 and 6)**



## **2.6 Summary Findings: Load Effects by Span Length and Scenario**

- Scenario 1 consistently yields 10 percent greater load effects (for positive flexure, negative flexure, and shear) than the 3-S2 control vehicle for all span lengths.
- Scenario 2 yields approximately 25 percent greater positive moments when compared with the 3-S2 control vehicle for short spans (less than 60 ft.); however, the difference becomes less pronounced and stabilizes at around 13 percent for spans longer than 60 ft.

For shear load effects, the increase due to Scenario 2 varies between 10 percent and 24 percent for spans shorter than 80 ft. For longer span lengths, the USDOT study team observed a fairly stable trend where the average difference is 17 percent.

For negative flexure, Scenario 2 yields similar load effects at very short span lengths (20 ft. +/-). The difference increases as the span length increases, but stabilizes for spans greater than 40 ft., with an average difference of 14 percent.

- Scenario 3 yields approximately 35 percent greater positive moments than the 3-S2 control vehicle for short spans (less than 60 ft.); however, similar to the behavior observed for Scenario 2, the difference becomes less pronounced and stabilizes at around 20 percent for spans longer than 60 ft.

For shear load effects, the difference varies between 20 percent and 34 percent for spans shorter than 80 ft. For longer span lengths, a fairly stable trend was observed where the average increase is 25 percent.

For negative flexure, Scenario 3 yields 10 percent greater load effects when compared with the 3-S2 control vehicle for very short span lengths (20 ft. +/-). The difference increases with increasing span lengths, but stabilizes to some degree for spans greater than 40 ft., with an average difference of 22 percent.

- Scenario 4 generates around 40 percent greater positive moments than the 2-S1-2 control vehicle for very short spans (20 ft. +/-). The difference diminishes linearly with increasing span lengths, and stabilizes at around 13 percent for spans in excess of 60 ft.

Shear load effects are 30 percent greater than the control vehicle for very short spans (20 ft. +/-); however, the difference is less pronounced as the span length increases, and is stabilized at around 11 percent for spans in excess of 100 ft.

For negative flexure, a similar behavior was observed as with the case for shear. Negative moments are 21 percent higher than the control vehicle for very short spans (20 ft. +/-); however, the difference diminishes with increasing span lengths and stabilizes at around 13 percent for spans in excess of 100 ft.

- Scenario 5 consistently yields 10 percent greater positive moments than the 2-S1-2 control vehicle for spans up to 80 ft. For longer spans the difference in positive moments appears to increase with increasing span length.

For this Scenario shear load effects are about 8 percent greater than for the control vehicle for spans up to 60 ft. For longer span lengths the difference tends to increase as the span length increases.

Negative flexure exhibits a rather complex behavior for the Scenario 5 vehicle. For instance, a maximum increase of 50 percent in the calculated negative moment was observed for a span length of 80 ft.

- Scenario 6 displays a complex behavior for spans less than 80 ft., where the difference between this configuration and the 2-S1-2 control vehicle varies between 35 percent and 55 percent. However, for spans greater than 80 ft., the difference increases as the span length increases, as was the case for Scenario 5.

Shear load effects are around 25 percent greater than the baseline vehicle for very short spans (20 ft. +/-), and tend to increase as the span length increases.

Negative flexure exhibits complex behavior in the case of Scenario 5 where a maximum relative increase of 86 percent in the calculated negative moment over that of the control vehicle was observed for a span length of 80 ft.

### CHAPTER 3 – ONE-TIME BRIDGE REHABILITATION/REPLACEMENT COSTS

In order to estimate the probable one-time cost effect of employing alternative truck configurations in each scenario, the USDOT study team developed a methodology that estimates the relative increase in cost relative to the base vehicles. A rating factor (RF) of 1.0 was set as the acceptance criteria when determining bridge improvement needs. It should be noted that the one-time cost of bridge improvements addressed herein could pertain to either superstructure strengthening or superstructure replacement triggered by the need to increase live load capacity. The choice of strengthening vs. replacement would depend on superstructure type and whichever is the more economical alternative. For instance, for a short span concrete slab or T-beam superstructure, replacement may be preferred over strengthening or rehabilitation. For a steel girder bridge, however, strengthening or rehabilitation may be a more economical way to increase load capacity than full superstructure replacement.

It should be noted that the costs presented in this chapter represent the extreme upper bound of possible costs that might result from the introduction of the alternative truck configurations in each scenario. In addition, there are significant cost mitigating factors and neither the actual costs nor the lower bound costs are determinate due to the range of program and policy decisions available to the States. Furthermore, the methodology does not take into account any cost- or budget-driven decisions that may be made by the State DOTs and does not address State DOT policy alternatives that may initiate more refined analysis or load testing options to improve load ratings. Cost estimates are based on total project costs and not just the construction costs.

The study team considered bridge rehabilitation or replacement costs for all alternative truck configuration scenarios on both the Interstate and other NHS roadways, regardless of whether some vehicles (triple trailers for instance) may be excluded for safety or other reasons. As with the structural analysis (**Chapter 2**) and as outlined in the *Modal Shift Comparative Analysis*, the parameters for the one-time cost assessment assume the scenario vehicles are able to travel wherever their control vehicles could operate. For analytical purposes triple trailer combinations (Scenarios 5 and 6) are assumed to be restricted to a 74,500 mile network of Interstate and other principal arterial highways. One-time costs assessed in this study take into account the findings related to changes in vehicle use patterns estimated in the Modal Shift Comparative Analysis would result from the travel estimated for each of the alternative vehicle configurations.

The methodology entailed the following nine-step process:

1. Determine the distribution of span lengths in the sample database as percentages separately for Interstate bridges and other NHS bridges (see Chapter 2 of this document).
2. Calculate the cost of bridge rehabilitations for each span length interval as:

$$\text{Cost} = \text{Bridge Length} \times \text{Deck Width} \times \text{Unit Price for Rehabilitations per ft}^2$$

Bridge lengths were taken as the upper limit in the interval (e.g., for 20-40 ft. spans, use 40 ft.). Deck width was taken as 64 ft. (4 x 12 ft. lane + 2 x 8 ft. shoulder) for Interstate bridges and as 48 ft. (3 x 12 ft. lane + 2 x 6 ft. shoulder) for other bridges on the NHS.

**The unit price, based on total project costs, for replacement or strengthening was**

**taken as \$235 per sq. ft.** This value is an approximation of the following costs lumped together:

- Construction cost;
- Design (8 percent to 20 percent depending on the project size);
- Construction inspection- and design-related assistance (13 percent);
- Work zone traffic control;
- Substructure rehabilitation;
- Mobilization (4 percent); and
- Other costs, including:
  - Railing and transitions;
  - Joints and approach pavements; and
  - Striping, grooving and sealing the deck, etc.

Based on the parameters given above, approximate bridge rehabilitation costs for Interstate bridges and other NHS bridges are listed in **Table 23**.

**Table 23: Cost of One Time Bridge Rehabilitations, per Bridge**

Span Length [ft.]	Cost of One Time Rehabilitation for IHS Bridges	Cost of One Time Rehabilitation for Other Bridges on the NHS
<20	\$300,000	\$230,000
20-40	\$600,000	\$450,000
40-60	\$900,000	\$680,000
60-80	\$1,200,000	\$900,000
80-100	\$1,500,000	\$1,130,000
100-120	\$1,800,000	\$1,350,000
120-140	\$2,110,000	\$1,580,000
140-160	\$2,410,000	\$1,800,000
160-180	\$2,710,000	\$2,030,000
180-200	\$3,010,000	\$2,260,000

3. Determine the percentage of bridges rated less than 1.0 in the structural analysis for each alternative truck configuration scenario for each span interval (See **Chapter 2** of this document).
4. Determine the total number of Interstate bridges and other NHS bridges in the NBI inventory (See **Chapter 2** of this document).
5. Estimate the actual number of bridges in each span interval using the distributions observed for the sample database.

6. Determine the projected number of bridges with  $RF < 1.0$  for each configuration scenario by multiplying the percentage of bridges rated less than 1.0, calculated in step 3, by the number of bridges in each span interval, calculated in step 5.
7. Determine the cost of bridge rehabilitations for each span interval for each truck type, separating Interstate bridges from other bridges on the NHS, by multiplying the cost calculated for a single bridge for that span interval by the projected number of bridges with  $RF < 1.0$  for each truck scenario.
8. Add costs from each span interval to determine the total costs for each scenario. The total rehabilitation costs for each alternate truck configuration are listed in **Table 24** and **Table 25** for Interstate bridges and other bridges on the NHS, respectively.
9. Calculate  $\Delta cost$  for each scenario.  $\Delta cost$  is the difference in the cost of rehabilitations due to an alternative truck configuration and that from the related control vehicle. Projected  $\Delta costs$  are given in **Table 26**.

For Alternative Trucks Configurations – Scenarios 1, 2 and 3,  $\Delta costs$  were determined as:

$$\Delta cost_{\text{Scenario 1}} = Cost_{\text{Scenario 1}} - Cost_{3-S2}$$

$$\Delta cost_{\text{Scenario 2}} = Cost_{\text{Scenario 2}} - Cost_{3-S2}$$

$$\Delta cost_{\text{Scenario 3}} = Cost_{\text{Scenario 3}} - Cost_{3-S2}$$

For Alternate Trucks Configurations – Scenarios 4, 5 and 6,  $\Delta costs$  were determined as:

$$\Delta cost_{\text{Scenario 4}} = Cost_{\text{Scenario 4}} - Cost_{2-S1-2}$$

$$\Delta cost_{\text{Scenario 5}} = Cost_{\text{Scenario 5}} - Cost_{2-S1-2}$$

$$\Delta cost_{\text{Scenario 6}} = Cost_{\text{Scenario 6}} - Cost_{2-S1-2}$$

## Bridge Structure Comparative Analysis Technical Report

**Table 24: Projected Total Rehabilitation Costs for Interstate Bridges**

Vehicle	One Time Rehabilitation Costs for Span Length Intervals										TOTAL
	<20 ft	20-40 ft	40-60 ft	60-80 ft	80-100 ft	100-120 ft	120-140 ft	140-160 ft	160-180 ft	180-200 ft	
3-S2	-	\$354,790,000	\$267,160,000	\$353,360,000	-	\$528,970,000	-	-	-	-	\$1,504,280,000
Scenario 1	-	\$354,790,000	\$267,160,000	\$353,360,000	-	\$528,970,000	-	-	-	-	\$1,504,280,000
Scenario 2	-	\$354,790,000	\$267,160,000	\$353,360,000	-	\$528,970,000	-	-	-	-	\$1,504,280,000
Scenario 3	-	\$354,790,000	\$534,320,000	\$717,770,000	-	\$528,970,000	-	-	-	-	\$2,135,850,000
2-S1-2	-	-	\$267,160,000	\$353,360,000	-	-	-	-	-	-	\$620,520,000
Scenario 4	-	\$354,790,000	\$267,160,000	\$353,360,000	-	-	-	-	-	-	\$975,310,000
Scenario 5	-	-	\$267,160,000	\$353,360,000	-	\$528,970,000	-	-	-	-	\$1,149,490,000
Scenario 6	-	\$354,790,000	\$267,160,000	\$1,071,130,000	\$441,700,000	\$528,970,000	-	-	\$804,440,000	\$893,500,000	\$4,361,690,000

**Table 25: Projected Total Rehabilitation Costs for Other Bridges on the NHS**

Vehicle	One Time Rehabilitation Costs for Span Length Intervals										TOTAL
	<20 ft	20-40 ft	40-60 ft	60-80 ft	80-100 ft	100-120 ft	120-140 ft	140-160 ft	160-180 ft	180-200 ft	
3-S2	-	\$292,070,000	\$353,780,000	\$116,600,000	-	\$172,980,000	-	-	-	-	\$935,430,000
Scenario 1	-	\$580,250,000	\$440,560,000	\$116,600,000	-	\$172,980,000	-	-	-	-	\$1,310,390,000
Scenario 2	\$29,710,000	\$755,490,000	\$700,890,000	\$233,190,000	\$147,710,000	\$172,980,000	-	-	-	-	\$2,039,970,000
Scenario 3	\$29,710,000	\$930,730,000	\$881,120,000	\$233,190,000	\$288,990,000	\$172,980,000	-	-	-	-	\$2,536,720,000
2-S1-2	-	-	-	-	-	\$172,980,000	-	-	-	-	\$172,980,000
Scenario 4	-	\$292,070,000	\$173,550,000	\$233,190,000	-	\$172,980,000	-	-	-	-	\$871,790,000
Scenario 5	-	-	\$86,780,000	\$116,600,000	-	\$172,980,000	-	-	-	-	\$376,360,000
Scenario 6	-	\$350,480,000	\$614,110,000	\$233,190,000	\$288,990,000	\$351,530,000	-	-	-	-	\$1,838,300,000

**Table 26: Projected  $\Delta$ costs for Interstate Bridges and Other Bridges on the NHS**

<b><math>\Delta</math>costs for Alternate Configurations</b>	<b>Projected Total Cost of Rehabilitation of Interstate Bridges</b>	<b>Projected Total Cost of Rehabilitations Other NHS Bridges</b>	<b>Projected One-Time Cost All NHS Bridges</b>
<b><math>\Delta</math>cost Scenario 1</b>	-	\$0.4 B	\$0.4 B
<b><math>\Delta</math>cost Scenario 2</b>	-	\$1.1 B	\$1.1 B
<b><math>\Delta</math>cost Scenario 3</b>	\$0.6 B	\$1.6 B	\$2.2 B
<b><math>\Delta</math>cost Scenario 4</b>	\$0.4 B	\$0.7 B	\$1.1 B
<b><math>\Delta</math>cost Scenario 5</b>	\$0.5 B	\$0.2 B	\$0.7 B
<b><math>\Delta</math>cost Scenario 6</b>	\$3.7 B	\$1.7 B	\$5.4 B

**Chapter 4 – SCENARIO COST SUMMARIES**

As noted in *Volume I: Comprehensive Truck Size and Weight Limits Study – Technical Summary Report* as well as in the other reports on modal shift, pavement, compliance, and safety that comprise Volume II, none of the scenarios studied involve increases in weight for more than a single vehicle configuration. The analysis did not in any way consider the possible cost effects of the introduction of various combinations of the different alternative truck configurations in a single scenario.

With respect to the one-time structural costs, multiple alternative truck configurations would likely impact many of the same bridges identified as needing strengthening or replacement. Therefore, scenario cost summaries would overlap extensively with respect to specific bridges.

**Table 27: Scenario 1-6 Summary**

		Interstate Highway System	Non-IHS NHS	Total
<b>SCENARIO 1:</b> 5 Axle 3-S2 (CS5) GVW = 88,000 lbs.	*One-Time Bridge Strengthening or Replacement Costs	---	\$0.4 B	\$0.4 B
<b>SCENARIO 2:</b> 6 Axle 3-S3 (CS6) GVW = 91,000 lbs.	*One-Time Bridge Strengthening or Replacement Costs	---	\$1.1 B	\$1.1 B
<b>SCENARIO 3:</b> 6 Axle 3-S3 (CS6) GVW = 97,000 lbs.	*One-Time Bridge Strengthening or Replacement Costs	\$0.6 B	\$1.6 B	\$2.2 B
<b>SCENARIO 4:</b> 5 Axle 2-S1-2 (DS5) GVW = 80,000 lbs.	*One-Time Bridge Strengthening or Replacement Costs	\$0.4 B	\$0.7 B	\$1.1 B
<b>SCENARIO 5:</b> 7 Axle 2-S1-2-2 (DS7) GVW = 105,500 lbs.	*One-Time Bridge Strengthening or Replacement Costs	\$0.5 B	\$0.2 B	\$0.7 B
<b>SCENARIO 6:</b> 9 Axle 3-S2-2-2 (DS9) GVW = 129,000 lbs.	*One-Time Bridge Strengthening or Replacement Costs	\$3.7 B	\$1.7 B	\$5.4 B

\*Costs are in 2011 dollars, rounded to the nearest \$100 Million. As noted in Section V of this report, the calculated one-time structural costs represent the “extreme upper bound of possible [bridge strengthening or replacement] costs”.

**Observations**

***Assumptions***

- Annual Bridge Capital Costs are based on 2011 (base year) FMIS cost summaries, including both the State and Federal shares.
- Bridge damage costs are equated to the total related repair and replacement project costs (inclusive of design, construction inspection, etc.).



- Maximum legal weights for each truck class are used for structural analysis and for fatigue analysis.

***Limitations***

- Costs derived for both the one-time structural related issues are independently investigated for each scenario. The costs for multiple scenarios are by the nature of the analysis not additive.
- The reported one-time structural related costs represent an extreme upper bound.
- Distortion induced fatigue in steel members is not included in the study.
- While an extensive literature search was conducted and expounded upon, study schedule and time constraints only supported the detailed analysis of representative bridges.
- Load and Resistance Factor Rating (LRFR) capability was not available in AASHTO's ABrR software for the structural analysis of trusses and girder-floor-beam bridges (consequently, LFR was used for those bridge types).
- Outputs from the modal shift modeling effort produced data that did not distinguish between intra-modal (truck-to-truck) and inter-modal (between modes) shifts.

## CHAPTER 5 - ASSESSMENT OF BRIDGE FATIGUE AND INVESTIGATION INTO BRIDGE DECK WEAR

This section presents the methodology that the USDOT study team implemented to estimate fatigue implications associated with trucks operating above current Federal size and weight limits compared to trucks operating at and below those limits. The chapter also discusses the implications associated with each of the scenarios. The study team's extensive investigation into a generally accepted approach for modeling bridge deck wear is presented in this chapter as well. It should be noted that no such generally accepted approach was found and, as a result, the cost implications that the scenarios have on bridge deck wear were not calculated and so are not included in the Study.

The objective of this area of the study is to compare the impacts on bridge fatigue that trucks operating above current Federal truck size and weight limits have compared to the impacts resulting from trucks operating at and below those limits. A parallel objective is to evaluate the effects of alternative truck configurations in each of the six scenarios on the fatigue life of steel bridges through a comparative analysis. This will include both a general review of fatigue effects on steel superstructures and a study of the effects of the alternative configurations versus those of the control vehicles on four typical steel bridges.

### **5.1 Fatigue-related Effects**

#### Types of Fatigue

This part of the study is focused on evaluating the effect of primary load-induced fatigue in steel bridges.

Fatigue damage in steel bridges is generally categorized as either load-induced or distortion-induced. Load-induced fatigue is due to in-plane stresses in the steel plates that comprise bridge member cross sections. Distortion-induced fatigue is due to secondary stresses in the steel plates that comprise bridge member cross sections. Typically, the effects of secondary stresses are seen at connections to primary members. This type of fatigue is usually associated with unintended fixity, the state of being stable or fixed, or distortion at these connections and can only be evaluated through a very sophisticated level of analysis that, as such, is beyond the scope of this study. The fatigue process can take place at stress levels that are substantially less than those associated with failure under static loading conditions. Fatigue damage originates from microscopic discontinuities in the material under cyclic loading. Discontinuities are typically a result of weldments with incomplete penetration, porosity, incomplete fusion, or trapped slag at a connection. Fatigue can also be focused at a simple weld termination, or it can occur at any stress concentrator; for example, at locations affected by impact or construction-related damage. These discontinuities can cause stress concentrations that are much higher than that which the member is designed to withstand. Fatigue life depends not on the basic strength of the structural element, but on the actual stresses at these discrete points at attachments or at points of abrupt change in section. Thus, the current method for estimating fatigue life in steel is based on three factors:

- The number of cycles of loading to which the member is subjected,
- The type of detail at the area of concern, and

- The stress range at the location of the detail.

### Factors Impacting Steel Fatigue

Load-induced fatigue has been observed in steel components for more than 140 years. The modern approach to fatigue design of fabricated steel structures was primarily developed during the 1960s and early 1970s. This research identified the following major factors impacting fatigue life:

#### *Residual Stress*

Tensile residual stresses related to welded details are induced into the connected parts during the weld cooling process. As the weld cools and in order to maintain equilibrium, a relatively small portion of the connected part goes into tension. The actual distribution and magnitude of the tensile stress depends upon several factors such as material strength, sequencing of the welds, geometry of the connected parts, and size of the weld. The magnitude of this tensile residual stress can reach the yield strength of the material.

As per AASHTO, residual stresses due to welding are implicitly incorporated into the assumption of allowable stress range limits with the specification of stress range as the sole stress parameter.

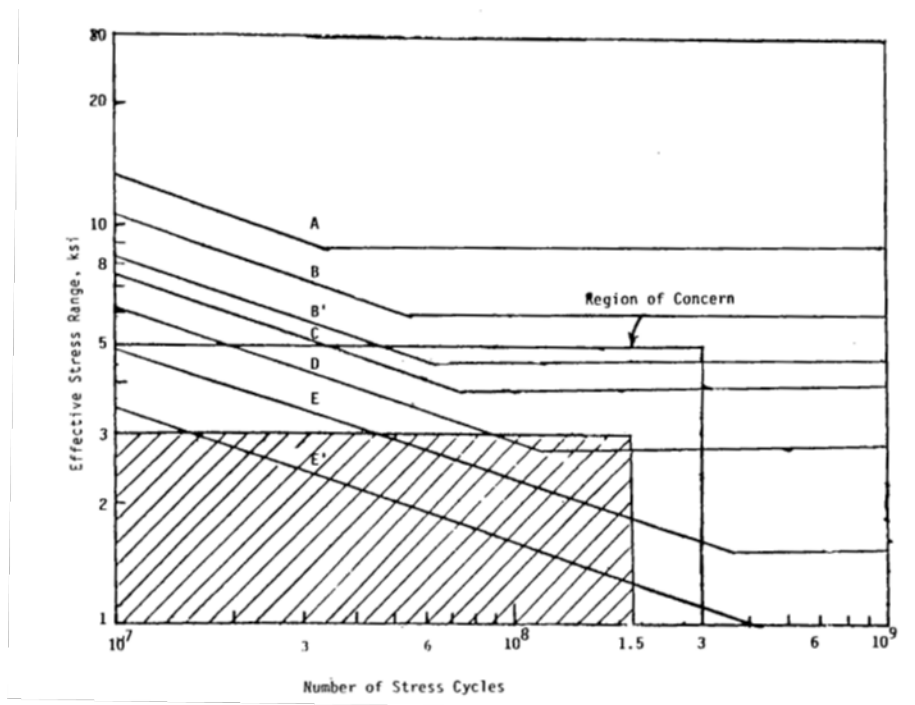
#### *Stress Range*

It is generally agreed that stress range is the dominant factor impacting steel fatigue life. Experimental data and fracture mechanics principals have shown that fatigue damage is proportional to the cube of the stress range amplitude (from “Fatigue Impacts on Bridge Cost Allocation,” 1998, Laman et al., 1998). This means that if the stress range is doubled the fatigue damage will increase by a factor of eight. Two limit states of stress range (infinite life vs. finite life) must be considered when evaluating fatigue life. The constant amplitude fatigue threshold (CAFT) is a stress range or limit state below which an applied, constant stress range will not create fatigue damage and the detail will theoretically have infinite life.

A structure rarely experiences a constant stress range; therefore, the calculated stress ranges due to site-specific data must be considered to be below half of the CAFT or the variable amplitude fatigue threshold (VAFT) to achieve no fatigue damage and to theoretically experience infinite fatigue life. If the particular detail of concern fails to achieve these thresholds, a more complex finite life fatigue evaluation is required.

#### *Stress Cycles*

The number of stress cycles in a structure is proportional to the number of trucks that cross the bridge during its service life. Fatigue life evaluation is performed based on the assumptions that each truck loading cycle causes some damage. The damage caused by each truck depends on the weight, the bridge’s span length, and member section properties. Researchers and structural engineers primarily use Miner’s Rule to determine the fatigue life considering this cumulative effect of stress cycles. This method assumes that the damage in just one stress cycle is  $1/N_i$  if  $N_i$  cycles of a specific stress range  $S_i$  are needed to cause a structural detail to fail.



**Figure 32: Region of Concern for Fatigue in Highway Bridges**

(Source: *NCHRP Report 299: Fatigue Evaluation Procedures for Steel Bridges*, 1987)

### *Steel Fatigue Details*

Bridge connection details are grouped into categories labeled A to E' (E-prime) based on their level of fatigue strength. This strength is for load induced fatigue caused by in-plane bending stress. The details in each category have approximately the same level of stress concentrations and comparable fatigue lives. S-N curves, which show the number of cycles to failure,  $N$ , for a given constant stress range,  $S$  (See **Figure 32** above), have been developed for each fatigue detail category. These curves are based on extensive laboratory data by Fisher et al. (1970) and Fisher et al. (1974). Because of the scatter in test data, the curves represent the lower bound of predicted fatigue life with a 95 percent confidence level for a 95 percent possibility of survival. With regard to the S-N curves in **Figure 32**, an inner region of concern is enclosed within an area bounded by a stress range of 5 kilo-pounds per square inch (ksi) and by 10 million and 300 million stress cycles. The 5-ksi stress range represents an approximate upper bound observed on actual bridges. The majority of the stress ranges observed on actual bridges have been between 1 and 3 ksi. The expected stress cycles on most bridges are between 10 million and 150 million. This produces the cross hatched area of greater concern bounded by stress ranges of 3 and 1 ksi, and cycles of 10 million and 150 million.

The S-N curves for fatigue detail categories D through E' are within this area of greater concern. This observation is consistent with experience in that fatigue failure has not been reported for categories A through C, but has occurred in categories D, E and E'. Also from the AASHTO LRFD Design Specifications C6.6.1.2.3, "Experience indicates that in the design process the fatigue considerations for Detail Categories A through B' rarely, if ever, govern." And from NCHRP Report 299, 1987, the situation where the maximum stress range in tension falls below

the fatigue limit for a particular detail “applies primarily to higher detail categories (C and above).”

### *Axle Weights vs. Truck Weights*

The 72,000-lb. HL93 fatigue truck<sup>2</sup> is used to represent the large variety of actual trucks of different configurations and weights. The fatigue truck has a constant dimension of 30’ between main axles with a maximum axle weight of 32,000 lbs. This arrangement approximates the four- and 5-axle trucks that do most of the fatigue damage to bridges.

From the “Influence of Heavy Trucks on Highway Bridges,” (Wang et al., 2005), it was observed that traffic-induced flexural stress does not necessarily increase with gross vehicle weight (GVW), but is highly related to axle weights and configurations. Also, from “Fatigue of Older Bridges in Northern Indiana due to Overweight and Oversized Loads – Volume 1: Bridge and Weigh-In-Motion Measurements,” (Reisert et al., 2006) it was noted that:

*...shorter spans show little GVW to moment effect correlation. However, the correlation improves as the span length increases. When comparing truck induced moment on spans shorter than 60 feet there is very little difference in the moments induced by 5 axle and 11 axle trucks. However, for spans greater than 60 feet, as the span length increases the moments induced by 11 axle trucks are significantly higher than those induced by 5 axle trucks.*

By evaluating the strain data from a bridge that was instrumented for a 2005 study, Wang and Liu found that there was very little difference in maximum strain (and stress) ranges induced by a 5-axle, 80,000-lb. trucks and the 9- and 11-axle 134,000-lb. trucks. The five-axle 80,000 lb. truck did, however, produce the largest maximum strain range. In “Fatigue Impacts on Bridge Cost Allocation” (Laman et al., 1997), researchers found that factors influencing the level of fatigue damage caused by a given vehicle are axle weights and spacing.

### Current Code Approach to Steel Fatigue

Current code approach<sup>3</sup> is based upon Miner’s linear damage rule concerning the cumulative process of fatigue and the determination of stress range as it relates to the stress-life approach. The fatigue evaluation procedure requires calculating the effective stress range at the un-cracked detail of concern. This can be performed by using the fatigue truck, site-specific data, or stress measurements. From the effective stress range, a maximum stress range is calculated and compared to a constant amplitude fatigue threshold for infinite life. If this maximum stress is greater than the threshold, the effective stress is then used to determine finite fatigue life.

### Summary of Research Findings and Positions on the Subject:

The following recent research findings and positions on the subject are in chronological order:

---

<sup>2</sup> Fatigue truck intended for fatigue loading, the magnitude and configuration of which is based on AASHTO LRFD 2007, Article 3.6.1.4.1.

<sup>3</sup> “Current code approach” for structural design is a member-based approach where the safety of individual members contributes to a cumulative safety effect for the entire structure.

- a. “Effects of Increasing Truck Weight on Steel and Pre-stressed Bridges,” (Altay et al., 2003). This study evaluated the effects of increasing the legal truck weight by 10 or 20 percent on five steel girder bridges and three pre-stressed I-girder bridges that were instrumented. It was discovered that all modern steel girders and most bridge decks could tolerate a 20 percent increase with no reduction in fatigue life. Older steel bridges designed in the 1970s and 1980s would experience a reduction in remaining life of up to 42 percent for a 20 percent increase in truck weight and a 25 percent reduction for a 10 percent increase in truck weight.
- b. “Truck Loading and Fatigue Damage Analysis for Girder Bridges Based on Weigh-in-Motion Data,” (Wang et al., 2005). Based on data collected by WIM measurements, this study evaluated the effects of heavy truck traffic on six steel bridges. The heaviest trucks observed were almost twice the weight of the HS20-44, 72,000-lb. vehicle; however, all the axle weights were less than the 32,000-lb. axles of the HS20-44 vehicle. Through the damage accumulation analysis, it was found that the actual truck traffic closely correlates the effects of the fatigue design truck and that the heavy traffic will not cause severe fatigue problems on steel girders with fatigue details of categories A, B and C.
- c. “Fatigue of Older Bridges in Northern Indiana due to Overweight and Oversized Loads – Volume 1: Bridge and Weigh-In-Motion Measurements,” (Reisert et al., 2006). This study evaluated the effects of truck traffic along an extra heavy weight corridor on one steel bridge. The trucks ranged in GVW from 54,400 lbs. for the Class 9 vehicles to 119,500 lbs. for the Class 13 vehicles. The Fatigue Categories C and D were investigated. Based on the results of the study, the structure was shown not to be susceptible to fatigue failure.

#### Assessment of Fatigue Formulas and Their Implications with Respect to the Alternative Truck Configurations Being Considered

Fatigue life is inversely proportional to the cube of the effective stress range and will therefore be sensitive to small changes in loading for the limit state of the finite life cycle. Depending on the CAFT limit of AASHTO fatigue prone details, differences in the axle weight and spacing of the vehicle classes and weight groups may result in significantly different fatigue damage to the bridge inventory. The potential effects on the Nation’s bridges from the increased sizes and weights associated with the alternative truck configurations in each of the six scenarios were investigated. Inherent in the following assessment is the reality that the widespread use of any of the proposed alternative truck configurations would likely only constitute a modest increase (relative to the sheer size of the present truck fleet and truck traffic stream) in total loading cycles for any given bridge. This does not negate the possibility of a significantly larger contribution of incremental fatigue damage that could be attributed to an alternative truck configuration for its loading cycles. It does however put the issue into perspective. Any significant difference in the fatigue affects attributable to a particular alternative truck configuration must be considered in light of the relative percent of loading cycles assumed to be attributable to that scenario. For greater insight into the projected increase in scenario vehicles due to mode shift, see the *Mode Shift Comparative Analysis* segment of the 2014 CTSW Study.

To illustrate the fatigue damage potential of these proposed alternative truck configurations in each of the six scenarios, four typical existing steel bridges were selected for comparative

analysis. Two of them are simply supported steel girder bridges and the other two are continuous steel girder bridges. The steel girders on these bridges comprise either rolled shape beams with partial length cover plates or plate girders with horizontal lateral bracings welded to the bottom flanges of the girders. The USDOT study team conducted the analysis in accordance with the AASHTO *Manual of Bridge Evaluation* (2<sup>nd</sup> Edition) with 2014 interim revisions and the AASHTO *LRFD Bridge Design Specifications* (6<sup>th</sup> Edition). All of the four chosen bridges have finite fatigue life cycles per the analysis.

Given that fatigue life is inversely proportional to the cube of the effective stress range and assuming that the stress cycles for each truck configuration in the new fleet of trucks is constant, a baseline can be established for the two 80,000-lb. control vehicle truck configurations using the following equation:

$$\text{Baseline Fatigue (Value A)} = \frac{1}{(\Delta f)_{cal}^3} \text{ (Control Vehicle)}$$

Where  $\Delta f_{cal}$  = the calculated effective stress range at the locations of concern

Using this same equation, a similar calculation can be performed for the effective stress range for each alternative truck configuration.

$$\text{Alternative Truck Configuration Fatigue (Value B)} = \frac{1}{(\Delta f)_{cal}^3}$$

By comparing this value to the control vehicle fatigue value, an order of magnitude change in the fatigue life attributable to each scenario vehicle can be determined using the following equation:

$$\text{Change (percent)} = (B/A) - 1$$

The following truck data, including two 80,000-lb. control vehicles and six alternative truck configurations, were used for modeling purposes (See **Figure 33**).

## Bridge Structure Comparative Analysis Technical Report

Configuration	Description	Details									
Control Vehicle CS5 (3S2)		Axle Data									
		Axle Locations	0	197	247	739	789				
		Allowed Max. Loads (kips)	12.0	17.0	17.0	17.0	17.0				
Truck 1 CS5 (3S2) ATC 1		Axle Data									
		Axle Locations	0	197	247	739	789				
		Allowed Max. Loads (kips)	12.0	19.0	19.0	19.0	19.0				
Truck 2 CS6 (3S3) ATC 2		Axle Data									
		Axle Locations	0	197	247	688	739	789			
		Allowed Max. Loads (kips)	12.0	15.8	15.8	15.8	15.8	15.8			
Truck 3 CS6 (3S3) ATC 3		Axle Data									
		Axle Locations	0	197	247	688	739	789			
		Allowed Max. Loads (kips)	12.0	17.0	17.0	17.0	17.0	17.0			
LCV Control Vehicle 2S1-2 (DS5)		Axle Data									
		Axle Locations	0	138	372	499	753				
		Allowed Max. Loads (kips)	12.0	17.0	17.0	17.0	17.0				
Truck 4 2S1-2 (DS5) ATC 4		Axle Data									
		Axle Locations	0	138	419	499	800				
		Allowed Max. Loads (kips)	12.0	17.0	17.0	17.0	17.0				
Truck 5 2S1-2-2 (DS7) ATC 5		Axle Data									
		Axle Locations	0	138	372	499	753	880	1134		
		Allowed Max. Loads (kips)	12.0	15.6	15.6	15.6	15.6	15.6	15.6		
Truck 6 3S2-2-2 (DS7+) ATC 6		Axle Data									
		Axle Locations	0	197	247	406	456	583	837	964	1218
		Allowed Max. Loads (kips)	12.0	14.6	14.6	14.6	14.6	14.6	14.6	14.6	14.6

Note: Axle locations are measured in inches from the steering axle.

Gross vehicle weight and axle loads are expressed in units of 1000 lb. or “kips”.

**Figure 33: Control Vehicles and Alternative Truck Configurations in Each of the Six Scenarios**



Bridge #1: 42’-9” Simply Supported Rolled Girder Bridge with Welded Cover Plates

The existing bridge consists of six simply supported spans located at Lake Katrine Rd. (County Route 90), spans over Interstate 87 in New York, and was built in the 1950s. Span 4 of the bridge was chosen for the analysis. The superstructure of Span 4 is composed of W24 rolled girders with welded cover plates terminated at 8’-4” from the supports. The span is skewed at 30°. The fatigue detail category of the welded cover plate is ‘E’ (E-prime). The reinforced concrete deck is composite and the structural deck is 6 ½” thick. A line girder analysis was performed for an interior girder.

The results of the comparative analysis are shown as follows:

**Table 28: Bridge #1 Results**

Scenarios (1-3)	<b>Incremental Percent Change in the Relative Contribution to the Bridge’s Fatigue Life With Respect to the 3-S2 Control Vehicle</b>	
	Begin Cover Plate	End Cover Plate
3-S2 80k Control Vehicle	0	0
Scenario 1: 3-S2 88k	-25	-25
Scenario 2: 3-S3 91k	-31	-31
Scenario 3: 3-S3 97k	-45	-45
Scenarios (4-6)	<b>Incremental Percent Change in the Relative Contribution to the Bridge’s Fatigue Life With Respect to the 2-S1-2 Control Vehicle</b>	
	Begin Cover Plate	End Cover Plate
2-S1-2 LCV Control Vehicle	0	0
Scenario 4: 2-S1-2 80k	-17	-17
Scenario 5: 2-S1-2-2 105.5k	29	29
Scenario 6: 3-S2-2-2 129k	-58	-58

Note: A positive value indicates a decrease in the alternative truck configuration’s incremental effect on the bridge’s fatigue life relative to the control vehicle and a negative value indicates an increase in the alternative truck configuration’s incremental effect on the bridge’s fatigue life relative to the control vehicle.

Bridge #2: 133’ Simply Supported Welded Plate Girder Bridge with Welded Lateral Bracing

The existing bridge consists of 20 simply supported spans located at the Empire State Plaza Artery Westbound over Ramp I-787 NB to the South Mall in Albany, New York and built in 1967. Span 20 of the bridge was chosen for the analysis. The superstructure of span 20 is composed of welded steel plate girders with a welded gusset plate that connects the lateral bracing at mid-span. The fatigue detail category of the detail is ‘E’. The reinforced concrete deck is composite and the structural deck is 7-1/2” thick. A line girder analysis was performed for an interior girder.

The results of the comparative analysis are shown as follow:

**Table 29: Bridge #2 Results**

Scenarios (1-3)	Incremental Percent Change in the Relative Contribution to the Bridge's Fatigue Life With Respect to the 3-S2 Control Vehicle
	Center of Span
3-S2 80k Control Vehicle	0
Scenario 1: 3-S2 88k	-25
Scenario 2: 3-S3 91k	-29
Scenario 3: 3-S3 97k	-42
Scenarios (4-6)	Incremental Percent Change in the Relative Contribution to the Bridge's Fatigue Life With Respect to the 2-S1-2 Control Vehicle
	Center of Span
2-S1-2 LCV Control Vehicle	0
Scenario 4: 2-S1-2 80k	4
Scenario 5: 2-S1-2-2 105.5k	-23
Scenario 6: 3-S2-2-2 129k	-61

Note: A positive value indicates a decrease in the alternative truck configuration's incremental effect on the bridge's fatigue life relative to the control vehicle and a negative value indicates an increase in the alternative truck configuration's incremental effect on the bridge's fatigue life relative to the control Vehicle.

Bridge #3: 361'-4" Three Span Continuous Rolled Girder Steel Bridge with Welded Cover Plates.

The existing bridge is located in Knoxville, Tennessee on Interstate I-40. It spans over Norfolk Southern Railroad and a cross street. It was originally constructed in the 1960s and widened in the 1980s. The bridge consists of three continuous spans of approximately 128', 132' and 101'. The superstructure is composed of W36 rolled girders with welded cover plates in the both positive and negative moment regions. The fatigue detail category of the welded cover plate is 'E' due to the thickness of the bottom flange. The reinforced concrete deck is composite in the positive moment regions and is 8 1/2" thick. The bridge supports three lanes of traffic west bound and four lanes east bound. A line girder analysis was performed to determine the stress ranges at the termination of the cover plates on the bottom flange in the positive moment regions. The results of the comparative analysis are as follows:

**Table 30: Bridge #3 Results**

Scenarios (1-3)	Incremental Percent Change in the Relative Contribution to the Bridge's Fatigue Life With Respect to the 3-S2 Control Vehicle					
	Span 1			Span 3		
	Begin Cover Plate	End Cover Plate	Begin Cover Plate	End Cover Plate	Begin Cover Plate	End Cover Plate
3-S2 80k Control Vehicle	0	0	0	0	0	0
Scenario 1: 3-S2 88k	-26	-26	-26	-26	-25	-27
Scenario 2: 3-S3 91k	-41	-36	-38	-39	-33	-44
Scenario 3: 3-S3 97k	-52	-48	-49	-50	-46	-54
Scenarios (4-6)	Incremental Percent Change in the Relative Contribution to the Bridge's Fatigue Life With Respect to the 2-S1-2 Control Vehicle					
	Span 1			Span 3		
	Begin Cover Plate	End Cover Plate	Begin Cover Plate	End Cover Plate	Begin Cover Plate	End Cover Plate
2-S1-2 80k Control Vehicle	0	0	0	0	0	0
Scenario 4: 2-S1-2 80k	8	6	8	6	3	10
Scenario 5: 2-S1-2-2 105.5k	-18	-21	-19	-18	-10	1
Scenario 6: 3-S2-2-2 129k	-64	-63	-64	-63	-54	-59

Note: A positive value indicates a decrease in the alternative truck configuration's incremental effect on the bridge's fatigue life relative to the control vehicle and a negative value indicates an increase in the alternative truck configuration's incremental effect on the bridge's fatigue life relative to the control vehicle.

Through this analysis it was discovered that the stress ranges at the bottom cover plate terminations in span 2 did not exceed ½ of the un-factored permanent dead load compressive stress. Therefore, the bottom flange cover plate terminations in span 2 are always in compression, and therefore, the results for this span were not reported in the table above.

Bridge #4: Five-span, continuous welded plate girder steel bridge with welded lateral bracing

The existing bridge is a five-span, multi-girder bridge located in New York, on Northern Boulevard over Interstate Route 90 and NYC railroad. The bridge was originally built in 1971 and is skewed 7 degrees 40 minutes at Piers 3 and 4. The interior girder (G2) was chosen for the analysis. The span lengths for G2 are 142', 185', 139'-3", 122', and 106'. The welded steel plate girder is composite with a 7-1/2" thick concrete deck. Lateral bracings are located at the center of the spans welded to the bottom flange of the girders. The fatigue detail category is E. A line girder analysis was performed for girder G2.

The result of the comparative analysis for Bridge #4 follows:

**Table 31: Bridge #4 Results**

Scenarios (1-3)	Incremental Percent Change in the Relative Contribution to the Bridge's Fatigue Life With Respect to the 3-S2 Control Vehicle				
	Span 1 (142ft)	Span 2 (185ft)	Span 3 (139.26ft)	Span 4 (122ft)	Span 5 (106ft)
3-S2 80k Control Vehicle	0	0	0	0	0
Scenario 1: 3-S2 88k	-25	-25	-25	-25	-26
Scenario 2: 3-S3 91k	-31	-31	-31	-31	-34
Scenario 3: 3-S3 97k	-44	-44	-44	-44	-46
Scenarios (4-6)	Incremental Percent Change in the Relative Contribution to the Bridge's Fatigue Life With Respect to the 2-S1-2 Control Vehicle				
	Span 1 (142ft)	Span 2 (185ft)	Span 3 (139.26ft)	Span 4 (122ft)	Span 5 (106ft)
2-S1-2 80k Control Vehicle	0	0	0	0	0
Scenario 4: 2-S1-2 80k	2	2	2	3	3
Scenario 5: 2-S1-2-2 105.5k	-31	-30	-26	-15	-8
Scenario 6: 3-S2-2-2 129k	-66	-65	-64	-61	-60

Note: A positive value indicates a decrease in the alternative truck configuration's incremental effect on the bridge's fatigue life relative to the control vehicle and a negative value indicates an increase in the alternative truck configuration's incremental effect on the bridge's fatigue life relative to the control vehicle.

As stated earlier, the above results demonstrate the incremental effects of alternative truck configurations for each scenario on these real-world bridges as compared to the incremental effects of truck usage by the more common control vehicle configurations in terms of percentage change in fatigue life, assuming that the stress cycles for each of the vehicles is constant. To determine the changes in the absolute fatigue life of the bridge resulting from alternative configurations, further study is required based on the percentage of each ATC in the fleet, ADTT for a particular corridor, and the number of stress range cycles.

Conclusions:

The results of this comparative analysis indicate that relatively higher axle loads or more closely spaced axles negatively impact fatigue life when compared to the two 80 kip control vehicles. For instance, Scenario 1 has the same axle spacing as the single control vehicle, but has 12 percent higher main axle weights, resulting in an incremental 25 to 27 percent negative effect on

fatigue life for Bridges #1 through #4. Scenario 2 and Scenario 3 both result in significant incremental negative effects on fatigue life when compared to the single control vehicle due to their closely spaced tri-axle configurations. This confirms that the addition of the third axle to the rear axle grouping results in a negative effect on fatigue life on the order of 29 to 54 percent for Bridges #1 through #4.

The axle spacing effect is also evident when comparing Scenario 6 with the double control vehicle. Scenario 6 will have a negative incremental effect on fatigue life of up to 66 percent due to the addition of closely spaced axles even though each individual axle weight is less than that of the double control vehicle.

Notably, all details analyzed for bridges above are for the limit state of finite fatigue life. Depending on bridge span length, fatigue details, and the ratio of partial welded cover plate length to span length, some bridge details may have infinite fatigue life regardless of use by the control vehicle or an alternative configuration.

As stated earlier, this comparative analysis with the fatigue truck shows the relative effect on fatigue life of each scenario vehicle compared with the two control vehicles. The absolute effect of the general acceptance of any one of the scenario vehicles can only be measured in terms of changes in Years of Remaining Life. Due to unknown factors such as AADT, percentage of alternatively configured vehicles relative to the entire fleet, etc., the study team is unable to make a clear prediction of the absolute remaining fatigue life change. However, it is worthwhile to keep in mind that alternatively configured vehicles are a relatively small percentage of an entire fleet of trucks and that the bridge repair cost for steel fatigue damage is small compared to the total bridge program cost.

## **5.2 Bridge Deck Deterioration, Service Life, and Preventative Maintenance**

### ***Introduction***

#### **Scope & Purpose:**

Bridge decks are the most visible component of the bridge to the traveling public and one of the most costly elements of bridges in terms of maintenance repairs, rehabilitation, and replacement. In the United States, bridge decks have an effective service life ranging between 35 and 50 years, depending on truck traffic, the environment (climate and use of chlorides) and the bridge owner's bridge preservation practices. Transportation agency strategies to prolong deck life are often driven by budget, truck traffic, and environmental factors, and research has shown that these factors are intimately linked. The purpose of this effort is to explore the effect that trucks have on bridge decks and specifically the projected effects that the six scenario configurations, which are above the current Federal GVW limits, have on bridge decks.

The scope involved two efforts related to bridge decks. The first effort focused on bridge deck preservation and preventative maintenance, and the second addressed bridge deck repairs and replacement. Over the course of the research conducted, it became apparent that the two subtasks could not be independently explored and were related topics dealing with bridge deck service life.

With regard to the bridge owner's practice, expenses and costs are driven by agency goals and level of effort involved in keeping bridge decks in a serviceable condition, regardless of the forces and environmental factors that drive the deterioration. However, a distinction (or assumption) should be made at the onset of this discussion regarding operations and maintenance (O&M costs) vs. capital costs. O&M costs are on-going expenses usually borne internally by the owner agency, whereas capital costs are one-time costs for deck repairs and replacement that are typically beyond the direct maintenance capacity or capability of the owner agency.

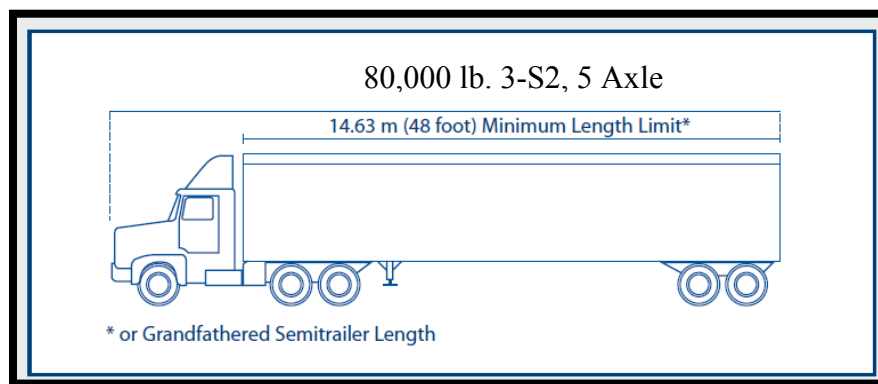
This discussion will be limited to reinforced concrete (RC) bridge decks. These decks represent 95 percent of all bridge decks on the highway networks under study. Other bridge deck types such as orthotropic, steel gratings, Exodermic<sup>®</sup> bridge deck systems, etc. are outside the scope of this document and behave differently under load.

An extensive literature search was conducted on reinforced concrete bridge decks as an initial step. The team reviewed the AASHTO *LRFD Bridge Design Specification*, 6th Edition, to rehearse the current assumptions for the design philosophy for bridge decks with references that were followed up and recorded. The Transportation Research Board's (TRB) vast resources were investigated, leading to the identification of numerous research papers and TRB publications on the subject. The team investigated the activities and policies of the various departments of transportation (DOTs) throughout the United States and reviewed several international sources, including the Japanese Public Works Research Institute (PWRI), which is noteworthy in producing research documentation on concrete fatigue deterioration mechanisms. All the various documentation and resources are listed in **Appendix A**.

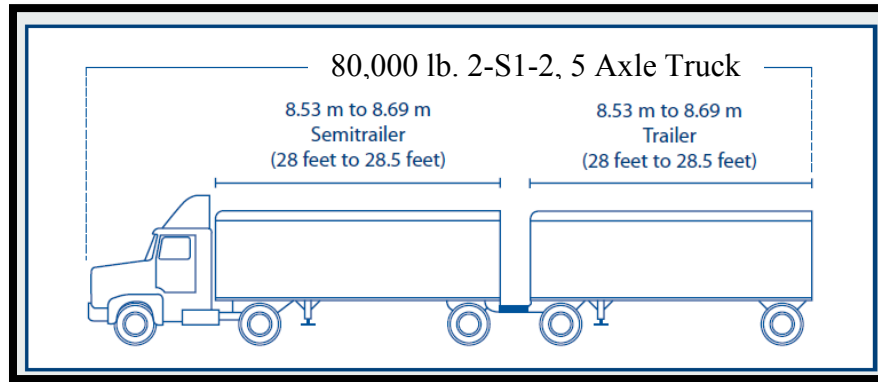
### ***The Effect of Trucks on Bridge Decks***

During the course of this investigation, the study team determined the following:

- Truck axle weights are the cause of primary damage to bridge decks, (Matsui, 1991, Perdikaris et. al., 1993, Tanaka et al., 2009)
- The majority of trucks driven on the highway networks are Class 9, 3-S2 (CS5, five-axle trucks). This truck configuration is the single control vehicle for this study, as shown in **Figure 34**. The double control vehicle is an STAA 28.5' double, also a five-axle 80,000 lb. truck, shown in **Figure 35**.



**Figure 34: STAA 53' (max) Semitrailer Single Control Vehicle**



**Figure 35: STAA 28' Double Control Vehicle**

### Research Approach

The USDOT study team examined owner-agency practices and policies regarding bridge deck preservation and preventative maintenance from a variety of sources. The main resources were the transportation agency web sites and the Transportation Research Board (TRB) publications and synthesis documents (NCHRP Report 397, 2009 and NCHRP Report 668, 2010, whereby other researchers conducted State surveys on a variety of related topics). The research by Dr. George Hearn, (Hearn, 2012), "Deterioration and Cost Information for Bridge Management," was found to be particularly useful in this area. This document also points out that State DOTs use a variety of tools such as the AASHTO bridge management tool formerly known as PONTIS<sup>®</sup> (now called AASHTOWare<sup>™</sup> Bridge Management). Some State DOTs use the PONTIS<sup>®</sup> output in conjunction with a deterioration modeling software that determines the rate of deterioration of a specified bridge asset and when action is needed by State DOTs to prolong the bridge element (such as the structural deck) life.

### Data Collection

Unit Cost Data was collected from the following States:

Alabama, Arkansas, California, Colorado, Connecticut, Delaware, Florida, Georgia, Indiana, Louisiana, Missouri, Nebraska, New York, Ohio, Virginia, Pennsylvania, Tennessee, Washington DC, and Wisconsin.

### Assumptions / Limitations

- When the owner agency takes action (or if the owner agency does not take action), in combination with the materials specified for use in preserving the deck all have a direct bearing on the service life of the RC bridge deck.

- Bridge deck repair and replacement costs are considered relative to the introduction of each of the six scenario configurations. They are the primary capital cost contributors to the overall load-induced costs analyzed in **Chapter 4**. As such they represent “damage costs.” The total damage that accumulates in the bridge deck over time is the result of both environmental factors (including ice, snow and resulting use of de-icing chlorides) and traffic factors (or load-induced).
- The load-induced damage in the early- to mid-service life of concrete decks is primarily the result of internal cracking and crack propagation due to stresses and strains. Likely causes of cracking are concrete shrinkage (Krauss and Rogalla, 1996), truck overloads (Kostem 1978, Fu et al., 1992, 1994), and the lack of full consolidation during construction. Wheel loads have been shown as the catalyst, if not the initiator, of fatigue damage during the early life cycles of the deck. Wheel overloads accelerate fatigue damage because of the resulting stress concentration at the tip of the cracks. Cracks then propagate under wheel load cycles and cause further deterioration. This damage accelerates as the wheel load moving across the crack causes the two concrete surfaces to rub on each other during the mid to late service life phase.
- In the mid- to late-service life of decks, where de-icing chlorides are applied, the resulting corrosion and the expansion of the reinforcing bars accelerates the deterioration of the deck.

### ***Bridge Deck Deterioration Mechanisms***

The mechanisms of deck deterioration resulting from the various sources, such as trucks and the environment, will be described in this sub-section.

#### AASHTO LRFD Bridge Design Specifications and Commentary on Concrete Deck Behavior

*Research has shown that primary structural resistance [toward the end of deck life] is not by flexural behavior, [but] rather by a complex internal membrane stress state referred to as internal arching or dome behavior. As the concrete cracks develop in the positive moment region of the slab, the neutral axis shifts upward and in-plane membrane forces develop as a result of lateral confinement provided by the surrounding concrete slab, and by the rigid primary members. The arching creates an internal compressive dome [more like a membrane, with the arching effect arising secondarily]. The failure occurs as a result of over-straining around the perimeter of the wheel footprint. The ultimate failure mode is that of punching shear. The arching action cannot resist the full wheel load; therefore, a small residual stress is resisted by flexure which is taken up by the steel reinforcing bars. The reinforcing bars also provide global confinement which is necessary for the membrane action and arching action to develop (Fang, 1985; Howleka et al, 1980) near the end of service life of the deck. All available data and tests indicate that the resistance to the wheel load using traditional design methods provides for a factor of safety that is at least 8-10 times the applied wheel load.*



As noted above, bridge decks exhibit the arching behavior during late stage service life. However, early on, the deck crack sizes are of a microscopic scale and are not yet interconnected. During the early phase, the primary mode of deck deterioration is related to flexure. It is only after numerous cyclic loadings of the deck that these micro-cracks begin to grow in size and number to the macroscopic scale needed to develop the arching action. It is difficult to determine when the deck transitions from the flexural to the so-called arching behavior.

### Reinforced Concrete Deck Serviceability Issues and Crack Induced Deterioration Mechanisms

While AASHTO considers the strength limit state of bridges, bridge owners or managers need also consider the serviceability limit states as well. These include deflection, vibration, crack growth and spalling on the structural deck surface.

The primary contributing factors with respect to deflection and vibration are axle loads and deck thickness. If the deck is too thin, excessive deflection can lead to extensive cracking and vibration. Vibration is also a function of the overall flexibility of the bridge deck and primary member system as well as the dynamic effects. Excessive vibration and movement can also be a cause of human discomfort, which is a serviceability issue.

Several research papers and one case study out of California illustrate the concepts from the AASHTO Design Specifications:

- Alabama DOT in conjunction with Auburn University conducted an investigation on the premature cracking of RC bridge decks on Alabama Highways. The paper, “Assessing the Cost/Benefits of Employing Thicker Bridge Decks” (Ramey et al., 2000), determined that Alabama highway bridge deck thicknesses were typically found to be 6” to 6.5”, and were 1.0” to 1.5” thinner than comparable bridge decks in other States. The cracking was found to be predominantly caused by truck axle weights, even though the decks were designed to carry the full weight of the design trucks. The Auburn research team also found through contractor interviews and cost data that the bridge decks could be replaced with thicker decks with only 2 percent to 3 percent in added costs compared to the cost of the 6” thick bridge decks. Furthermore, it was determined that the extra thickness could increase the bridge deck life by 10 percent to 50 percent. So, a minor increase in construction cost was shown to provide considerable long-term benefit in extending bridge deck service life.
- Research into the deterioration of RC decks has been advanced through the efforts of Shigeyuki Matsui (1999) in Japan and P. Perdikaris et al., (1993) at Case Western Reserve University. More recently, Yoshiki Tanaka et al., (2009) from Japan’s Public Works Research Institute (PWRI, Japan) conducted studies on the fatigue mechanism in concrete decks combined with the effects of de-icing salts.

These independent groups studied both the effect of static and dynamic wheel loads on RC decks. As stated earlier, the ultimate RC failure in decks is predominately due to shear failure. Deterioration starts with the presence of micro-cracks in the concrete caused by concrete shrinkage and other factors and the growth of these cracks is triggered by axle load cycles.

When transverse cracks are present, wheel loads cause differential movement of the deck from one side of the crack relative to the other side, causing the crack surfaces to rub against each other, both widening the crack and advancing the crack growth at the tip of the crack. A similar deflection occurs relative to longitudinal cracks; however, the stress range on one side of the crack would be higher than the other side. In each case the cracks develop in a pattern which is similar to the steel reinforcement grids present in the deck. The research by Yoshiki Tanaka, (et al., (2009) Public Works Research Institute (PWRI), Japan) clearly shows this grid-like crack pattern in the reinforced deck. In extreme cases the RC deck cracks turn from the vertical orientation to a horizontal orientation within the deck and arching action or membrane behavior takes over in resisting wheel loads.

The initial research (Tanaka et al., (2009) PWRI) showed that in early cycles (up to 16 percent of total service life) the slab resisted wheel loads in flexural mode. From about 16 percent of total service life to 84 percent of total service life (main life of span) the slab was exhibiting or transitioning to arching behavior. Beyond 84 percent of total service life the reinforcement provided increased tensile resistance and the slab/beam was acting as a “tied arch” or in membrane mode until failure. Also, after approximately 55 percent of total service life, the depth of the neutral axis relative to the center of the slab started to decrease dramatically, with an associated decrease in the elastic modulus.

Dynamic wheel load cycles cause the growth of grid like crack patterns on the bridge deck resulting in loss of strength and eventual punching shear failure. The presence of de-icing salts interacts with and accelerates the deterioration process.

- California Interstate Highway Bridge Case History, (Taken from NCHRP Report 495, 2003). This is a case history of two bridges in California. The first, the I-880 Nimitz Highway Bridge 33-0198 in Alameda County, which carries trucks, has worn at a much faster rate than the I-580 MacArthur Expressway Bridge (33-0324), which only carries passenger car and light truck traffic on a parallel highway. In the 37-year history of both bridges (recorded in the referenced document), the I-880 bridge deck was repaired and rehabilitated in the 29<sup>th</sup> year and continued to deteriorate, whereas the MacArthur Expressway bridge continues to operate with minor defects (transverse cracks and minor shallow spalls of 4” diameter or less).

Although the Nimitz Highway bridge deck was 1” thicker and had one major rehabilitation project, it exhibited more damage (e.g., spalls and large transverse cracks) than the thinner MacArthur Expressway Bridge that only allowed passenger vehicles and light trucks up to five tons at the end of the 37 year period.

#### *Chloride-Induced Deck Deterioration*

Contamination due to de-icing salts in cold, wet climate areas is a known accelerator of RC deck deterioration. Two similar studies by Virginia DOT (Williams et al., 2008) and Michigan DOT (Hu et al., 2011) have created deterioration models that predict the End of Functional Service Life (EFSL) in bridge decks due to de-icing salts.

The chloride contamination model asserts that The progressive corrosive effects of chlorides in concrete decks occur in 3 Phases:

*Phase 1 - Diffusion:* Chlorides migrate through the porous concrete surface through gravity and capillary action. The rate of migration of chloride salts into the concrete follows Fick's Second Law, which is a linear approximation with respect to time. The chloride concentration levels must reach a certain threshold at the steel reinforcement bar level to induce corrosion in the steel. During this phase the corrosion process has not yet began. This time, T1 is estimated to be between 5 to 10 years.

*Phase 2 - Rust Permeation & Accumulation:* Corrosive products such as chlorides begin to change the chemical makeup of the concrete around the reinforcing bars and start the formation of expansive rust oxidation products such as  $\text{Fe}_3\text{O}_4$ ,  $\beta\text{-FeO (OH)}$  and  $\text{Fe}_3\text{O}_3$ . Depending on the bar type time, T2 is estimated to initiate at 16 Years for bare steel and approximately 20 years for epoxy coated or galvanized steel. This is the period prior to corrosion-driven crack propagation and growth.

*Phase 3 - Crack Propagation:* Corrosion by product formation around the steel reinforcement bars has grown and expanded the concrete, exceeding the concrete's rupture strength. Cracks begin to propagate within the concrete and then reach the surface. Freeze-thaw action and axle loads potentially transform these cracks to delaminations and then to surface spalls. This time, T3 can be estimated to occur at between 25 and 35 years.

The predictive models use the parameters of time and the likelihood that a deck is in one of the deterioration phases described above. Both the VDOT (Williams et al., 2008) and MDOT (Hu et al., 2013) models use a "Monte Carlo" statistical approach to predict the remaining life of a bridge deck. In addition, Virginia uses the density of defects (cracks, delaminations and spalls) per square foot of bridge deck to measure the stage of deterioration and Maryland tends to use the deck condition ratings from bridge inspections.

*Combined Effect of Axle Loads and Chloride Contamination:*

Both the Virginia and Michigan DOT studies acknowledge that truck axle loads are the primary driver of deck deterioration, but neither can quantitatively model the effect of dynamic wheel loads with their chloride-induced deck deterioration models.

Tanaka et al. (2009 PWRI Japan) attempted to account for the effect of chlorides used to melt ice and snow in cold wet climates in conjunction with dynamic axle loads. The concrete fatigue mechanism and the chloride-induced deck deterioration mechanism are two separate processes; however, at some point in the life of the bridge deck, these two processes begin to interact with one another and serve to accelerate deck deterioration. The relationship and interaction of the two mechanisms are still not well understood. Additional research is needed in this area. Tanaka et al. (2009) found that asphalt overlays on highway bridge decks served to delay chloride contamination in the concrete deck and hence delay additional crack growth and propagation. However, no clear relationship was established. This finding would appear to be verifiable only in the late stage of the deck's service life.

### ***Owner-Agency Policies on Repair, Replacement and Preservation***

Owner agencies have policies in place that use a variety of tools to assist in their efforts to maintain the service life of bridge decks. A popular tool among many agencies is the AASHTO PONTIS<sup>®</sup> software. The software allows the user to store bridge inspection condition ratings and inventory data which is used to predict future condition ratings and recommend optimal preservation actions. This software is currently in use by 45 States and agencies. At least several State agencies have chosen to use PONTIS<sup>®</sup> supplemented by their own life-cycle analysis tools.

Virginia DOT uses the chloride contamination model described above along with a life cycle cost analysis to preserve and prolong bridge deck life. It is not clear if Michigan DOT has incorporated the model in its strategies, but they have employed “the mix of fix” philosophy as outlined in their *Capital Scheduled Maintenance Manual*.

The Nebraska Department of Roads, (NDOR) (Morcoux, 2011) uses a life cycle cost assessment software using bridge condition rating and a stochastic approach to predict bridge and bridge deck service life, 2011, Project SPR-P1 (11) M302. The life cycle cost stochastic method “uses transition probability matrices for predicting the deterioration of bridge elements over a given analysis period.” In other words it tries to predict the transition of the bridge element from one condition rating to a lower rating based on existing condition rating data derived from empirical data and the AASHTO PONTIS<sup>®</sup> software. While the system is analyzing all bridge elements, here we are specifically looking at bridge deck deterioration. The rating system follows the Federal condition rating system (9 = Excellent Condition to 0 = Failed Condition).

Linear prediction models are most reliable when applied to short time spans. The stochastic approach is based on Markov chain theory. The Markov decision process (MDP) is used to develop stochastic (random) methods that treat the facility deterioration process with one or more random variables that capture the uncertainty that influences the deterioration process. Models based on a Markov chain approach can be state-based or time-based.

The NDOR approach is state-based (Markov chains) and can be described by the 9 condition rating Levels (9 – 1, 0 excluded). This is a measure of the probability that the bridge deck rating transits to a lower condition rating. A transition probability matrix is developed and guided from a historic bridge element rating database such as PONTIS<sup>®</sup> and/or an expert engineering decision making process. The probability matrix tables are further refined by taking into account environmental factors such as ADT and ADTT, cold or wet climatic conditions that may dictate the usage of chlorides, materials used (black rebar vs epoxy coated), etc.

It should be noted that the stochastic method is limited in that it can only predict general trends and costs. It can tell you that for higher (truck) traffic volumes deterioration rates will increase, but it cannot predict which trucks cause more damage. So, while it can inform a life cycle cost analysis and recommend a repair strategy, it is not directly applicable to the goals of this study.

NCHRP Project 20-24 (11), Phase 1, 2002 – “Synthesis of Asset Management Practices” studied programs in Arizona, California, Colorado, Michigan, New York, Pennsylvania and Washington State. Project researchers also looked at programs in Australia, New Zealand and Canada. The study concluded that, while this is an evolving field, many DOTs currently have stand-alone

databases and methodologies that do not interact with other inter-agency databases. For example, bridge maintenance databases don't necessarily interact with highway maintenance databases, although many of them are using similar tools and approaches. As a result, the effectiveness of their efforts is diminished.

Another NCHRP Project (14-15) resulted in *NCHRP Report 668 – Framework for a National Database System for Maintenance Actions on Highway Bridges*. In this project, researchers worked with the objective of developing a framework for a national database system for collecting and archiving bridge maintenance actions, materials, methods, and assessments of their effectiveness. The research included a review of current practices relevant to reporting bridge maintenance programs and developed the framework for a data system for collecting, storing, and reporting information on the contexts, actions, and outcomes of bridge maintenance. The establishment of the National Bridge Management Database (NBMD) would be a major step in establishing a data sharing culture among State DOTs. This effort supports the development of FHWA's Long Term Bridge Performance program and is anticipated to provide the working data for predictive models.

### ***Comparison of State Unit-Cost Data***

As discussed above, owner agencies do not always define operations and maintenance (O&M) costs and capital rehabilitation and replacement costs in the same manner. In addition, State unit bid prices include dissimilar cost categories. This may be due to many factors:

- Climate – Some States, such as those in the southeast (e.g., Florida), rarely deal with ice or snow while others, such as those in the northeast, must deal with it regularly (e.g., New York or Vermont).
- Materials – For example, some States disallow the use of asphalt-based overlays (California Department of Transportation – as per Maintenance Policy Manual Chapter H, page H-16 and Indiana Department of Transportation as per 1999 internal memorandum, found in Frosch et al., 2013, **Appendix A**). These policies may be due to the fact that some repair materials just do not work well with their infrastructure, and the overlays tend to hide defects and trap water between the overlay and bridge deck, thus accelerating deterioration. On the other hand asphalt overlays are used in the New England States and in other countries with relative success (Frosch et al., 2013).
- Policy & Strategy– States develop policies and procedures to best suit their conditions. Some States have a complete replacement program in place, while others focus primarily on a preservation strategy.

The combination of all these factors leads to a wide array of options available to each owner agency for a given deck. There is some agreement among agencies. As stated in NCHRP Report 668,

*[State] DOTs recognize maintenance as distinct from new construction, replacement of structures, and major rehabilitation of structures. Cleaning, painting, and minor repairs are always maintenance. Replacement or modification of portions of bridges may be maintenance if projects are small and*

*have a short duration.” Emergency work, usually in response to accidents or extreme events, is classified as maintenance and can entail significant, temporary modifications of bridges.*

In comparing State unit-cost data, the USDOT study team looked at the effects that trucks that the six scenario configurations have on bridge decks. One approach was to look at States that allowed overweight trucks and compare their bridge deck wear experience with States that do not allow overweight trucks. This exercise was found to be futile, in part due to the reasons stated above with regard to variations in State definitions and because all States do allow heavier legal trucks with permits. Furthermore, bridge deck thickness, girder or floor-beam spacing, and other general characteristics are different from one bridge deck to another.

One other approach was to compare car-only lanes with truck lanes on the same bridge. On this task we contacted several State agencies, including the New York State Bridge Authority (NYSBA), which owns and maintains five Hudson River bridge crossings in the Mid-Hudson Valley area. Of these, the Newburgh-Beacon Bridge (I-84) east bound span was considered to be a good candidate for comparison.

The east-bound span can carry up to four lanes of traffic and the bridge is posted for 55 tons. Lane 1 (right most lane) is closed to traffic most of the time and is used by maintenance vehicles and as a shoulder. The two center lanes, Lanes 2 and 3, allow trucks, and the far left lane, Lane 4, allows passenger vehicles only. The difference in physical appearance of the two center lanes vs. the car-only lane is dramatic. Potholes and repair patches in the two center lanes occur at least an order of magnitude greater than in the car-only lane and shoulder.



Photo provided by Google Maps

**Figure 36: Photo of Newburgh-Beacon Bridge (I-84) Eastbound**

Indiana DOT was contacted to enquire about their heavy trucking corridor in the northern tier of the State (from Ohio & Michigan to Illinois) along the I-90 and US Route 20 corridor along with the Fort Wayne spur. Trucks less than 134,000 lbs. (67 tons) are allowed without a permit on US

Route 20. Trucks less than 45 tons are allowed without permits on portions of I-94. Indiana DOT stated that currently the agency does not track maintenance, repair, or rehabilitation of the bridge decks on and off the heavy trucking corridor separately, and no quantifiable data is available. However, bridge superstructure and decks on the toll roads and within 15 miles of a toll gate are designed for the heavier Michigan Train Truck Loading.

In addition, Indiana DOT and Purdue University are conducting a joint study to:

1. Determine stresses in Indiana bridges due to realistic over-weight truck loadings from WIM data,
2. Calculate the damage and deterioration caused by overweight trucks to Indiana Bridges,
3. Determine the reduction in service-life of bridges due to this damage, and
4. Determine the lifecycle costs of this damage in conjunction with the INDOT JTRP Report SPR-3502 (not yet released).

This joint study will provide estimates of damage and reduction in service-life by conducting a number of detailed, finite-element analyses of certain representative bridge models of different types under different realistic loading conditions based on WIM data. The results from these analyses will be compiled into empirical formulas and encoded into a software tool for use by INDOT.

In Vermont, the DOT conducted a 1-year pilot study (resulting in the *Vermont Pilot Program Report, 2012*) to allow 99,000-lb. trucks to travel on the Interstate System portion of the State's highways from 2009 to 2010. At the end of the study, the agency concluded:

*Bridge decks and deck wearing surfaces may be affected by heavier loads, but the costs to address these impacts are likely to be small in comparison to overall State highway expenditures. Other bridge components such as deck joints, bearings, piers, and abutments also may be affected, but these impacts cannot be quantified with currently available analytical tools. Long-term infrastructure costs will likely be less than for other States, especially given the relatively small truck volumes on those bridges.*

It is important to note, however, that Vermont has employed a design standard for its bridges that is based on a heavier design truck, and this may limit the applicability of lessons learned there to bridges in other States.

### ***Bridge Deck Preservation and Preventative Maintenance***

As part of this effort, the study team obtained unit costs for certain maintenance or construction activities. The purpose was not to seek unit cost bid data such as the cost of a cubic yard of Class C concrete that is routinely published in DOT databases for construction estimating, but rather to gather those project costs that would be necessary to complete a task such as bridge deck replacement and compare them with those costs that would be needed for bridge deck rehabilitation. These costs were in part derived from online data provided at websites maintained

by State DOTs; however, it was very difficult to discern what was included in the cost records. For example, there are cases where substantial amounts of highway realignment work at the bridge approaches is included, but this cost often includes other cost components such as work zone traffic control, construction inspection, and engineering oversight. In many cases, prices may have included one of these additional cost components but not the others, or included costs for non-standard items. As a result, the USDOT study team was able only to establish a range of unit costs and representative averages for any of the cost categories at best.

In addition to State DOT web sites, sources for unit cost data included direct State DOT contacts and unit cost published reports. The average costs were intended to support the average project costs derived for the Bridge Damage Deterioration Model. The findings, outlined below, are divided into a region that uses de-icing agents and one that does not (i.e., all other states).

**Region 1 (Northern States, De-icing agent users):** the study team found a large range of variability between the low and high costs.

- Deck repair costs ranged from a low of \$30.00/ft<sup>2</sup> to \$45.00/ft<sup>2</sup> with an average of \$36.00/ft<sup>2</sup>. Repairs could include crack sealing, spall patching, or overlays.
- Deck rehabilitation costs ranged from a low of \$42.00/ft<sup>2</sup> to \$125.00/ft<sup>2</sup> with an average of \$60.00/ft<sup>2</sup>. Rehabilitation could include partial depth hydro demolition & overlay or some other mode of removal. The price also includes incidentals such as removal and replacement of the bridge railings, pavement grooving, and striping.
- Deck replacement costs ranged from a low of \$65.00/ft<sup>2</sup> to \$147.00/ft<sup>2</sup> with an average of \$93.00/ft<sup>2</sup>. These costs included work zone traffic control, bridge railings, deck joint work, and construction inspection.

**Region 2 (All other States):**

- Deck repair costs ranged from a low of \$21.00/ft<sup>2</sup> to \$67.00/ft<sup>2</sup> with an average of \$33.00/ft<sup>2</sup>. Repairs could include crack sealing, spall patching or overlays.
- Deck rehabilitation costs ranged from a low of \$32.00/ft<sup>2</sup> to \$58.00/ft<sup>2</sup> with an average of \$42.50/ft<sup>2</sup>. Rehabilitation could include partial depth hydro demolition & overlay or some other mode of removal. The price also includes incidentals such as removal and replacement of the bridge railings, pavement grooving, and striping.
- Deck replacement costs ranged from a low of \$39.00/ft<sup>2</sup> to \$114.00/ft<sup>2</sup> with an average of \$66.00/ft<sup>2</sup>. These costs included work zone traffic control, bridge railings, deck joint work, and construction inspection.

See **Table 32** for a breakout of deck repair, rehabilitation and replacement unit costs by region and State.



**Table 32: Deck Repair, Rehabilitation and Replacement Unit Costs**

Connecticut	\$ 45.00	\$ 125.00	\$ 147.00
Delaware			\$ 72.00
Indiana		\$ -	\$ 110.00
Michigan	\$ 33.00	\$ 48.00	\$ 72.00
Missouri		\$ 45.00	\$ 65.00
New York			\$ 126.00
Ohio	\$ 30.00	\$ 48.00	\$ 85.00
Pennsylvania	\$ 41.00	\$ 42.00	
Virginia	\$ 35.00		
Wisconsin	\$ 33.00	\$ 50.00	\$ 66.00
<b>Region 1 Average</b>	<b>\$ 36.17</b>	<b>\$ 59.67</b>	<b>\$ 92.88</b>
Arkansas	\$ 21.00	\$ 32.00	\$ 56.00
California	\$ 75.00		\$ 92.00
Colorado	\$ 67.00		
Florida	\$ 21.00		\$ 41.00
Georgia		\$ 58.00	\$ 114.00
Louisiana		\$ 45.00	\$ 80.00
Nebraska	\$ 24.00		\$ 40.00
Tennessee	\$ 23.00	\$ 35.00	\$ 39.00
<b>Region 2 Average</b>	<b>\$ 33.00</b>	<b>\$ 42.50</b>	<b>\$ 66.00</b>

**Observations**

- According to AASHTO, bridge decks have 8 to 10 times more ultimate strength capacity than necessary to carry trucks up to a maximum GVW of 80,000 lbs., a strength-based limit state. Accordingly, bridge owner agencies will not have to replace bridge decks if any of the study scenarios are implemented.
- Although current bridge decks appear to have adequate ultimate strength to accommodate any of the scenarios, serviceability issues must be considered separately and may warrant thicker decks to reduce overall deck costs.
- Both short-term repair cycles and long-term deck replacement intervals are difficult to determine precisely since predictive models are either based on chloride contamination models, load-based (fatigue stress-cycle) models, or condition-based stochastic models alone.
- In the long term, bridge deck service life is driven by wheel and axle loads; however, the effect may be mitigated by low-cost preservation actions. Different States have adopted various tools, models and software programs to assist in the decision-making process. While these tools are not standardized, there is an ongoing effort to develop a national

database, the National Bridge Management Database (NBMD) to support FHWA's Long Term Bridge Performance program.

- Testing and research in bridge deck service life—which must include more than one deterioration mechanism (e.g., load-based testing in a dry vs wet environment)—has yet to be undertaken. Some long-term testing of bridge decks is underway, most notably in Indiana, to understand the long-term effects of heavy trucks on bridge decks and superstructures.

### ***Consideration of Impacts to Local Bridges***

An assessment of structural impacts that the six scenario vehicles would have on bridges located on non-Interstate NHS roadways would not differ from the results produced and presented in this study. Generally, local bridges feature shorter span lengths than bridges located on roadway networks with higher functional classifications. The design, construction, and management of local bridges vary greatly considering that there are thousands of independent local owners across the Nation with differing practices, and it is difficult to draw detailed conclusions about impacts. Although the USDOT study team did not use a sample of local bridges in this study, the majority of local bridges are short, simple (single) spans. Thus, we can look at the relative magnitudes of shears and moments generated by the scenario trucks for this span range and draw very broad conclusions. Figures 26 and 27 indicate that for short simple spans (20-40 ft.) Scenarios 2, 3, and 4 show an increase, Scenarios 5 and 6 show a decrease, and Scenario 1 is flat, related to flexural load effects as compared to control.

### **References**

Altay, K.A., Arabbo, D.S, Corwin, E.B., Dexter, R.J., French, C.E. (2003). “Effects of Increasing Truck Weights on Steel and Pre-stressed Bridges”. University of Minnesota. Minnesota Department of Transportation.

American Association of Highway and Transportation Officials (2011). Load Resistance Factor Design Specifications, 6<sup>th</sup> Edition, Washington DC.

American Association of Highway and Transportation Officials (2002). Standard Specifications for Highway Bridges, 17<sup>th</sup> Edition, Washington DC.

American Association of Highway and Transportation Officials (2013). The Manual for Bridge Evaluation, 2<sup>nd</sup> Edition with interim updates, Washington DC.

California Department of Transportation (CalTrans) (2006). Highway Maintenance Manual, Volume 1, Chapter H. <http://www.dot.ca.gov/hq/maint/manual/maintman.htm>

Cohen, H., Fu, G., Dekelbab, W., Moses, F. (2003). “Predicting Truck Load Spectra Under Weight Limit Changes and Its Application to Steel Bridge Fatigue Assessment”. American Society of Civil Engineering, Journal of Bridge Engineering, Vol. 8, No. 5, pp 312 – 322.

Engineering News Record, Published City Cost Indices, February 2014.

European Transport Sector (2008). *Cost Allocation for Transportation Infrastructure Sector* (CATRIN) Cost Allocation Practices in the European Transport Infrastructure Sector. European Union.

Fang, K.I., (1985). "Behavior of Ontario Type Bridge Deck on Steel Girders". PhD. Dissertation University of Texas

Fisher, J.W., (1977). "Bridge Fatigue Guide Design & Detail". American Institute of Steel Construction.

Frosch, R. J., M. E. Kreger, and B. Strandquist (2013). *Implementation of Performance-Based Bridge Deck Protective Systems*. Publication FHWA/IN/JTRP-2013/12. Joint Transportation Research Program, Indiana Department of Transportation and Purdue University, doi: 10.5703/1288284315214.

FHWA (2000). "Guidelines for Conducting A State Highway Cost Allocation Study Using the State HCAS Tool".

FHWA (2001). Analysis of the Vehicle Inventory and Use Survey for Trucks with Five-Axles or More. Office of Transportation Policy Studies

FHWA (2014), MAP-21 Comprehensive Truck Size and Weight Limits Study Website. Available at <http://www.ops.fhwa.dot.gov/freight/SW/map21tswstudy/index.htm> as of June 2014.

Fu, G., Alampalli, S. and Pezze, F. P. (1992) "Long-term Serviceability of Isotropically Reinforced Concrete Bridge Deck Slabs", TRB Transportation Research Record 1371, 1992

Fu, G., Alampalli, S., Pezze, F. P. (1994) "Lightly Reinforced Concrete Bridge Deck Slabs on Steel Stringers: A Summary of Field Experience", Final Report on R142 to FHWA, FHWA/NY/RR- 94/161, Engineering Research and Development Bureau, New York State Department of Transportation, June 1994

Hearn, G. (2012). "Deterioration and Cost Information for Bridge Management". University of Colorado.

Holowka, M.R.A., Dorton, R.A., Csagoly, P.F. (1980). "Punching Shear Strength of Restrained Circular Slabs". Ministry of Transportation and Communication, Ontario Canada

Hu, N., Haider, S., Bugueno, R., (2013). “Development and Validation of Deterioration Models for Concrete Bridge Decks: Phase 2: Mechanics Based Degradation Models” Michigan State University. Michigan Department of Transportation.

KLS Engineering & Wilbur Smith Associates (2010). “District Wide Truck Size & Weight Study” for the District Department of Transportation, Washington, DC.

Kostem, C.N. (1978). “Overloading Of Highway Bridges--Initiation of Deck Damage” Transportation Research Record No. 664, Bridge Engineering, Volume 1. Proceedings of the Transportation Research Board Conference.

Krauss, P.D., Rogalla, E.A. (1996). “Transverse Cracking in Newly Constructed Bridge Decks – United States”. National Research Council (U.S.), American Association of State Highway and Transportation Officials, National Cooperative Highway Research Program.

Laman, J.A., Ashbaugh, J.R., (1997). “Fatigue Impacts on Bridge Cost Allocation”. Paper 98-0417

Laman, J.A., Ashbaugh, J.R., (2000). “Highway Network Bridge Fatigue Damage Potential of Special Truck Configurations”, International Bridge Engineering Conference, National Research Council. TRB 1696.

Matsui, S., (1991). “Fatigue Deterioration Mechanism and Durability of Highway Bridge RC Slabs”. Report to Hanshin Expressway Public Corporation (in Japanese).

Morcous, G., (2011). “Developing Deterioration Models for Nebraska Bridges”, University of Nebraska, Nebraska Department of Roads

National Transportation Commission (NTC) (2005). *Third Heavy Vehicle Road Pricing Determination Technical Report*. Australia

Ohio Department of Transportation (2009). *Impacts of Permitted Trucking on Ohio’s Transportation System and Economy*, Final Report.

Pavement Interactive, link: <http://www.pavementinteractive.org/article/equivalent-single-axle-load/>

Perdikaris, P.C., Petrou, M.F., Wang A., (1993). “Fatigue Strength and Stiffness of Reinforced Concrete Bridge Decks”, Final Report to ODOT, FHWA/OH-93/016, Case Western Reserve University.

Reisert, J. A., and M. D. Bowman (2005). *Fatigue of Older Bridges in Northern Indiana due to Overweight and Oversized Loads, Volume 1: Bridge and Weigh-In-Motion Measurements*.

Publication FHWA/IN/ JTRP-2005/16-1. Joint Transportation Research Program, Indiana Department of Transportation and Purdue University, doi: 10.5703/1288284313378.

Ramey, G.E., Balmer, D.M., (2000). “Assessing the Cost/Benefits of Employing Thicker Bridge Decks in Alabama” Final Report. Highway Research Center, Auburn University.

Satoh, T., Mitamura, H., Adachi, Y., Nishi, H., Ishikawa H., Matsui, S. (2008). “Fatigue Durability of a Reinforced Concrete Deck Slab in a Cold Snowy Region”. Public Works Research Institute (PWRI), Civil Engineering Research Institute for Cold Region (CERI), Japan.

Tanaka, Y., Murakoshi, J., Nagaya, Y., (2009). “Fatigue and Corrosion in Concrete Decks with Asphalt Surfacing”. Public Works Research Institute (PWRI), Japan. Proceedings of the 25<sup>th</sup> US-Japan Bridge Engineering Workshop.

Transportation Research Board (1987). *Fatigue Evaluation Procedures for Steel Bridges*. NCHRP Report 299. Washington, DC.

Transportation Research Board (2000). *Manual for Condition Evaluation and Load Rating of Highway Bridges Using Load and Resistance Factor Philosophy*. NCHRP Project 12-46, Washington, DC.

Transportation Research Board (2003). *Effect of Truck Weight on Bridge Network Costs*. NCHRP Report 495. Washington, DC.

Transportation Research Board (2006). *Legal Truck Loads and AASHTO Legal Loads for Posting*. NCHRP Report 575. Washington, DC.

Transportation Research Board (2008). *State Highway Cost Allocation Studies; A Synthesis of Highway Practice*. NCHRP Synthesis 378. Washington, DC.

Transportation Research Board (2009). *Bridge Management Systems for Transportation Agency Decision Making*. NCHRP Report 397. Washington DC.

Transportation Research Board (2010). *Framework for a National Database System for Maintenance Actions on Highway Bridges*. NCHRP Report 668. Washington, DC.

Transportation Research Board (2011). *Directory of Significant Truck Size and Weight Research*. NCHRP Project 20-07, Task 303. Washington, DC.

Transportation Research Board (2002). Task 1 of 3: Synthesis of Asset Management Practice NCHRP Project 20-24(11), Phase 1. Washington, DC.

Transportation Research Board (2012). *Evaluation of Load Rating by Load and Resistance Factor Rating*. NCHRP Report 700. Washington, DC.

Transportation Research Board (2012). *Fatigue Evaluation of Steel Bridges*. NCHRP Report 721. Washington, DC.

*Vermont Pilot Program Report - a Truck Size and Weight Study* (2012). Report No. VT\_Pilot\_2012. Federal Highway Administration (FHWA), Office of Freight Management and Operations. Washington, DC.

Vehicle Information Use Survey, VIUS (1997). US Census Bureau. “The Analysis of the Vehicle Inventory and Use Survey for Trucks with Five-Axles or More”, 2000.

Wang, Liu, Huang, Shahawy (2005) “Truck Loading and Fatigue Damage Analysis for Grider Bridges Based on Weigh-in-Motion Data” American Society of Civil Engineers, *Journal of Bridge Engineering*, Vol. 10 p. 1- 12.

Williams, G., Weyers, R., Brown, M., Sprinkel, M. (2008). “Bridge Deck Service Life Prediction and Costs”. Virginia Polytechnic Institute, Virginia Transportation Research Council. Virginia Department of Transportation.

**APPENDIX A – REVISED DESK SCAN REPORT**

**TABLE OF CONTENTS**

**CHAPTER 1 – Introduction ..... 96**

**1.1 Purpose..... 96**

**CHAPTER 2 – Structural Impacts Due to Overweight Trucks..... 99**

**2.1 Documents on Methods and Impacts of the Bridge Strength Limit State..... 99**

    2.1.1 A Survey of Analysis Methods and Synthesis of the State of the Practice..... 99

    2.1.2 An Identification of Data Needs and an Evaluation and Critique of Available Data Sources ..... 99

    2.1.3 An Assessment of the Current State of the Understanding of the Impact and Needs for Future Research, Data Collection and Evaluation..... 100

    2.1.4 Quantitative Results of Three Past Studies ..... 100

    2.1.5 Summary of Three Past Studies ..... 102

    2.1.6 List of References ..... 103

**2.2 Documents on Methods and Impacts of the Bridge Fatigue Limit State..... 112**

    2.2.1 Introduction..... 112

    2.2.2 A Survey of Analysis Methods and Synthesis of the State of the Practice in Modeling Fatigue Impact..... 112

    2.2.3 An Identification of Data Needs and an Evaluation and Critique of Available Data Sources..... 114

    2.2.4 An Assessment of the Current State of the Understanding of the Impact and Needs for Future Research, Data Collection and Evaluation..... 115

    2.2.5 A Synthesis of Quantitative Results of Past Studies with Past Prospective and Retrospective Estimates in Each Category of Effect, Including Reasonable Ranges of Values for Impact Estimates..... 116

    2.2.6 Summary ..... 118

    2.2.7 List of References ..... 118

**2.3 Methods and Models Related to Accrued Bridge Damage Costs and Bridge Serviceability Limits..... 129**

    2.3.1 Introduction..... 129

    2.3.2 A Survey of Analysis Methods and A Synthesis of the State of Practice..... 129

    2.3.3 An Identification of Data Needs and An Evaluation and Critique of Data Sources ..... 136

    2.3.4 An Assessment of the Current State of Understanding of the Impact and Needs for Future Research, Data Collection and Evaluation ..... 136

2.3.5 Quantitative Results of Past Studies .....	137
2.3.6 List of References .....	137
<b>CHAPTER 3 – Bridge Deck Deterioration, Service Life and Preventative Maintenance .</b>	<b>154</b>
<b>3.1 A Survey of Analysis Methods and Synthesis of the State of Practice in Modeling Bridge Deck Impacts.....</b>	<b>154</b>
3.1.1 Bridge Deck Deterioration Model .....	154
3.1.2 State DOT Policies on Repair, Replacement and Preservation .....	156
<b>3.2 Data Needs and an Evaluation and Critique of Available Data Sources for Bridge Decks .....</b>	<b>156</b>
3.2.1 Comparison of State Unit Cost Data.....	156
<b>3.3 An Assessment of the Current State of the Understanding of the Impact and Needs for Future Research, Data Collection and Evaluation.....</b>	<b>157</b>
<b>3.4 Past Studies with Past Prospective And Retrospective Estimates in Each Category of Effect.....</b>	<b>158</b>
<b>3.5 List of References .....</b>	<b>159</b>
<b>3.6 Conclusion .....</b>	<b>166</b>
<b>CHAPTER 4 – List of Agencies .....</b>	<b>167</b>
4.1 National Academy of Sciences .....	167
4.2 Federal and State Transportation Agencies .....	167
4.3 Universities .....	167
4.4 Industry Standards and Publications .....	168
4.5 Foreign Resources.....	168



## CHAPTER 1 – INTRODUCTION

This report presents a revised version of the Bridge Task Desk Scan developed to support the Bridge Structure Comparative Analysis of the 2014 *Comprehensive Truck Size and Weight Limits Study (2014 CTSW Study)*. This revised Desk Scan addresses the recommendations made by the National Academy of Science (NAS) Peer Review Panel concerning the originally submitted version of this scan.

### **1.1 Purpose**

The purpose of the revised Desk Scan is to:

- Reorganize and enhance the original Desk Scan; and
- Add any additional, relevant content that may have been identified since the submission of the original Desk Scan.

Specifically, the NAS Peer Review Panel recommended that the original Desk Scan be reorganized to address four issues:

- Correlation of findings and discussions of cited references;
- Clarifications including to several references to and from prior studies; and identification of findings or correlations in prior studies common to the 2014 CTSW Study.

The purpose of this desk scan is to assess the extent to which specific changes in Federal truck size and weight limits might impact the nation's bridges. The potential impacts to be considered include direct and immediate structural effects and the resulting accrued damage to bridges over time. In addition, study subtasks include the effects of the proposed scenario truck configurations on the fatigue life of bridges; and on bridge deck deterioration, service life and maintenance. The NAS Peer Review Committee also enquired into the absence of discussion regarding bridge barriers, median barriers, railings, etc. The effects on these elements with respect to their capacity to resist errant 'Scenario' vehicles would more aptly be considered under the Safety Task. For this CTSW 2014 Study, the scope of the strength limit (structural analysis) case was confined to the evaluation of the primary member load bearing capacity. However, the dead load for those elements was accounted for in the ABrR bridge models.

There are of necessity fundamental differences in approach to these study areas. This is most evident with respect to the application of structural analysis. The assessment of structural impacts is based on a straight forward analysis of the structural effects of the proposed scenario trucks vs. those attributable to the control vehicle. As the load rating factor is based on specific truck configurations and assumed axle weights acting on specific bridges; the determination of the number of bridges, and in the end the costs associated with additional posting issues that

arise, are directly derived from this straightforward structural analysis for the representative sample of bridges. So, for the purposes of this study the load rating of bridges and the identification of resulting posting issues and costs is in the end a simple comparison of the structural effects of one truck to another: each scenario truck vs. the control vehicle. For load rating purposes, the maximum axle loads for each axle configuration are applied.

For the fatigue sub-study, one could use WIM data to perform a simple fatigue life analysis for representative bridges for a modal shift fleet vs. the existing truck fleet. But those results would be inherently limited to a comparison of the effects of the truck count for the existing fleet vs. that for the modal shift fleet. That approach treats all trucks as equal, ignoring the incremental effects of one truck vs. another. Alternatively, a comparison can be made between the incremental fatigue effects of the scenario trucks vs. the control vehicle, a direct comparison of truck vs. truck in terms of the resulting stress ranges at specific fatigue details on representative bridges. This is the approach adopted in the 2014 CTSW Study.

Several approaches have been employed historically to study bridge damage costs including: incremental costs associated with different truck weights applied to specific bridges; application of a very simplified structural analysis of idealized bridge types for a large bridge inventory using WINBasic; and, allocation of bridge damage responsibility share based on a factor reflecting an assumed causal relationship between some ‘allocator’ and overall damage costs. Some studies have also used fatigue analysis to help derive damage related bridge costs. Studies have been designed to answer different questions, and in some cases agencies have simply applied the methods developed for pavement costs to bridges; such studies have been limited to a relatively small sample of bridges, or just to a corridor. So, the past approaches to this study area have not been consistent. But it has been a goal of the bridge task team from the outset to answer the question of ‘what are the impacts (damage costs) associated with the proposed introduction of the scenario trucks’ on a national scale. This led the team to consider the viability of the various study approaches or methods to compare the effects of the modal shift fleet as a whole to those of the existing fleet. The general purpose of the Bridge Task Desk Scan is to conduct and document a literature search and provide literary technical support of various educational and industry supported institutions in the United States, Canada, Australia, Europe and Japan to inform the methods and means used in this 2014 CTSW Study’s Bridge Desk Scan. The primary intent is to identify any resources that may inform as to new approaches or refinements to existing approaches to: 1) the quantifying of structural demands on bridges due to ‘heavy’ truck loads (specifically with respect to six (6) alternative truck configurations; and/or 2) the derivation of resulting bridge capital costs. The process then involves an assessment as to the relevance and applicability of those approaches to this study.

This Desk Scan first considers the potential impacts resulting from the introduction of the six ‘Scenario Vehicles’, relative to those associated with the 80 kip Control Vehicles for the AASHTO strength, fatigue and serviceability limit state categories. The sub-study area of

concrete deck deterioration is more general in nature, with a consideration of impacts due to both overweight trucks and environmental effects.

Accordingly, this report is organized as follows:

2.0 Structural Impacts due to Overweight Trucks

2.1 Documents on Methods and Impacts related to the Bridge Strength Limit State:

- Under this section, methods and practices regarding one time bridge costs due to strength issues, such as load rating, are examined, summarized, and assessed with respect to their relevance to the current study.

2.2 Documents on Methods and Impacts related to the Bridge Fatigue Limit State:

- Under this section Methods and practices of analyzing fatigue impacts are examined, summarized, and assessed.

2.3 Documents on Methods and Cost Impacts related to Bridge Serviceability:

- Under this section, methods of modeling bridge long term deterioration and allocating associated accumulated bridge damage cost are examined, summarized, and presented.

3.0 Documents Modeling and Discussing Bridge Deck Impacts due to Overweight Trucks and Environmental Effects:

- Under this section, previous studies of deck deterioration are be examined, summarized, and assessed.

## CHAPTER 2 – STRUCTURAL IMPACTS DUE TO OVERWEIGHT TRUCKS

### **2.1 Documents on Methods and Impacts related to the Bridge Strength Limit State**

#### **2.1.1 A survey of analysis methods and synthesis of the state of the practice**

National Bridge Inspection Standards in Section 23 of Code of Federal Regulation Part 650.313(c) specifies that a bridge's safe load-carrying capacity is to be determined in accordance with the AASHTO Manual for Bridge Evaluation (MBE). Within the MBE there are three (3) methods to determine the safe load-carrying capacity, the Load and Resistance Factor (LRFD) method, the Load Factor (LRD) method, and the Allowable Stress (ASD) method. No preference is given to a specific method within the MBE. However, the AASHTO LRFD Bridge Design Specifications states in Section 1.1 that the methods provided within the LRFD manual are "encouraged". The LRFR methodology provides a systematic and more comprehensive approach to bridge load rating that is reliability based and provides a more realistic assessment of the safe load capacity of existing bridges. Therefore, the Load and Resistance Factor Rating (LRFR) method is generally accepted and many states have switched to or are switching to this method of analysis. AASHTO has analysis software (AASHTOWare Bridge Rating<sup>®</sup>; ABrR) which is used to calculate the Rating Factor (RF) for all three methods. If the RF is below 1.0 then that bridge is considered to have strength limit issues and some action is required. Potential actions or repairs include posting, strengthening, and/or replacing the bridge.

#### **2.1.2 An identification of data needs and an evaluation and critique of available data sources**

In order to perform a structural analysis and cost estimate for bridge strengthening or replacement three (3) key data categories need to be defined.

1. Bridge data: bridge geometry, member size, bearing fixity, and material properties are needed to model a bridge. The bridge data usually can be obtained through a review of record plans and field verification, if needed, but would not be feasible for a comprehensive national study. This bridge data necessary to build the models is readily available, but the sheer effort involved in reviewing hundreds of plan sets, let alone tens of thousands, would be daunting. Instead the team relied on obtaining existing and verified bridge models from various state DOTs and from NCHRP Project 12-78.
2. Live load data: for the ASD and LFD methods, AASHTO H20 and HS20 trucks or lane loads are used. For the LRFD method, three levels of evaluation are used, i.e.; design load (HL93) rating, legal load rating, and permit load rating. All three ratings should be calculated and the lowest rating determines the safe-load capacity for that bridge. More details pertaining to the LRFD safe-load analysis vehicles can be found in the MBE. In addition, states can designate their own live load configurations to determine safe-load capacity. In general, the bridge data have been inputted into computer models such as AASHTO's ABrR (VIRTIS) for bridge load rating purposes at the states' level. Historically ABrR (VIRTIS) models had been constructed using ASD or LFD methods, but in recent years ABrR (VIRTIS) models have been converted to the LRFR method.

However, at the time of this study Load and Resistance Factor Rating (LRFR) capability was not available in AASHTO's ABrR software for the structural analysis of two specific bridge types: trusses and girder-floor-beam bridges.

3. Unit costs for bridge strengthening, replacement or posting: unit cost data is typically referenced to past construction projects within a specific state or region. However, average unit costs vary greatly by state and region, and the reporting format also tends to vary. The cost of posting bridges is typically buried in the states' maintenance and operations programs. As such, it is not readily discernable as a distinct cost category and it is likely to be small relative to the replacement cost.

### **2.1.3 An assessment of the current state of the understanding of the impact and needs for future research, data collection and evaluation**

The methods to determine the load capacity based on ultimate strength has been extensively researched and standardized by AASHTO. AASHTO continues to refine these methods and implement updates to the Manual for Bridge Evaluation and the AASHTO LRFD Bridge Design Specifications. The flexibility providing for a bridge owner to use their own standard rating vehicle is already given and widely used among bridge owners. Once a bridge is determined not to meet the strength requirement in response to the live loads concerned, the owner would typically analyze replacement or strengthening costs versus the direct and indirect costs related to posting the bridge to determine the appropriate action.

### **2.1.4 Quantitative results of three past studies**

#### ***2.1.4.1 Results of the 'USDOT Comprehensive Truck Size and Weight Study, 2000'***

Bridges from 11 states were studied to extrapolate to the number of bridges requiring replacement in the US. The truck scenarios analyzed were the 2000 CTSW Study Base Case, the Uniformity Scenario (short wheel bases), the North American Fair Trade Act (triple axle vehicles), Longer Combination Vehicles, Triples, and H.R. 551 (intended to phase out trailers longer than 53', terminate state grandfather rights, and freeze national highway system weights). The National Bridge Inventory (NBI) and the FHWA WINBasic analysis software were used to determine the number of bridges that would need to be replaced. The 2000 CTSW Study was the first study to include both Live Load and Dead Load effects. However, the data obtained within the NBI is insufficient to determine the exact stresses. Using WINBasic, all bridges on the NHS were assigned to one of several archetypal bridge types, reflecting assumptions about the number of spans, length of longest span, etc. This approach doesn't yield precise results for any specific, real bridge, but it did allow for a quick, general assessment of the totality of the effects of truck loadings on bridges of various types on the NHS. A three part threshold was set to determine if a structure would be overstressed.

- Bridges rated up to H-17.5 with stresses exceeding 71.5% of the yield stress were assumed to be structurally deficient.
- Bridges with a rating greater than H-17.5 with stresses greater than 63% of the yield stress were assumed to be deficient.

- Bridges with an HS-20 rating with stresses greater than 57.5% of the yield stress were assumed to be structurally deficient.

If a bridge was determined to be overstressed, the proposed bridge replacement cost due to that vehicle was calculated. In addition to the one time replacement cost, a user cost was estimated to account for delays due to congestion during construction of the replacement bridge. A summary from the 2000 CTSW Study is included below.

**Table VI-2. Scenario Bridge Impacts**

Analytical Case	Costs (\$Billion)			Change from Base Case (\$Billion)			
	Capital	User	Total	Capital	User	Total	
1994 Base Case	154	175	329	0	0	0	
2000 Base Case	154	175	329	0	0	0	
<b>SCENARIO</b>							
Uniformity	134	133	267	-20	-42	-62	
North American Trade	44,000-pound tridem axle	205	378	583	51	203	254
	51,000-pound tridem axle	219	439	658	65	264	329
LCVs Nationwide	207	441	648	53	266	319	
H.R. 551	154	175	329	0	0	0	
Triples Nationwide	170	276	446	16	101	117	

This chart depicts the bridge capital (replacement) costs and the user costs calculated to result from the various alternative truck types studied, vs. the ‘Base Case’ costs.

**2.1.4.2 Results of the ‘Western Uniformity Scenario Analysis’:**

This study was to evaluate the cost effects of heavier, Longer Combination Vehicles (LCVs) in 13 western states. The bridge data obtained from the NBI was screened using WINBasic to bridges on the Interstate System and on the non-Interstate portion of the National Highway System. A base case vehicle was determined for each state based on existing fleet vehicles as a point of comparison with the ratings of the scenario vehicles. The cost to strengthen or replace a bridge was also calculated. Each of the 13 states reported a unit cost per square foot to replace a bridge. The deck area was increased by 25% because FHWA data shows that replacement bridges are on average 25% longer than the bridge they replace. Also, it was assumed that 50% of the bridges requiring replacement would be rehabilitated or strengthened. The rehabilitation cost was assumed to be 1/3 the replacement cost.

The number of overstressed bridges and the cost of strengthening or replacing the bridge was calculated in increments from 0% overstressed to 36.6% overstressed. It was also assumed that most states would not replace the bridge until the overstressing threshold was approximately half way between the Operating Rating and Inventory Rating. Based on this data and reflecting the two threshold overstress ranges, the one-time bridge replacement and/or rehabilitation cost for the corresponding 2,773 to 3,182 bridges in the 13 western states affected would cost between \$2.329 Billion and \$4.125 Billion.

**2.1.4.3 Results of the ‘Wisconsin Truck Size and Weight Study, 2009’**

The Wisconsin Truck Size and Weight Study evaluated the potential bridge replacement cost for six (6) overweight trucks. For this study, only bridges on state roads were used for analysis. The data was screened to select 84 bridges representing the type, length and age of Wisconsin bridges. Each scenario vehicle was analyzed using SEP. A minimum inventory rating was set for each vehicle type and bridge type to determine what bridges would require remediation. The results from the analysis of the 84 bridges was extrapolated to determine the number of bridges within the state that would require posting or replacement. For cost estimating purposes any bridge with a rating lower than the minimum limit set was assumed to require replacement. The study reported annual costs over a projected period of 10 years expected to result from the potential introduction of specific alternative truck configurations and weights. The total annual capital cost ranged as high as \$8.5 Million (\$85 Million over the 10 year period), for the six-axle 98,000 lbs. tractor-trailer. The results from the Wisconsin study are shown below.

**Table 7.2 Estimated Annual Bridge Replacement Costs**

Special Vehicle Configuration	State Route Bridge Replacement Costs	Local Route Bridge Replacement Cost
Six-Axle Tractor-Trailer, 90,000-Pound GVW (6-90)	\$0.04M	\$2.14M
Seven-Axle Tractor-Trailer, 97,000-Pound GVW (7-97)	\$0.28M	\$2.80M
Eight-Axle Tractor-Trailer, 108,000-Pound GVW (8-108)	\$0.04M	\$2.22M
Seven-Axle Single Unit, 80,000-Pound GVW (7-80)	\$0.78M	\$5.24M
Six-Axle Tractor-Trailer, 98,000-Pound GVW (6-98)	\$1.54M	\$6.94M
Six-Axle Tractor-Trailer and Pup, 98,000-Pound GVW (6-98 Pup)	\$0.72M	\$3.5M

Excerpt from Wisconsin Truck Size and Weight Study, 2009.

**2.1.5 Summary of Three Past Studies**

In the 2000 CTSW Study, we find an increase in the one-time national bridge replacement costs associated with the introduction of specific alternative heavier trucks ranges up to a maximum of \$65 Billion for the NAT truck with a 51,000 lb. triple-axle.

The ‘Western Uniformity Scenario Analysis’ study summarized the one-time rehabilitation/replacement costs for bridges in the thirteen western states (only) for Longer Combination Vehicles (LCVs). The range of one-time costs attributable to the introduction of those vehicles was found to be between \$2.3B and \$4.1B.

The ‘Wisconsin Truck Size and Weight Study, 2009’ reported annual bridge replacement costs over a projected period of 10 years expected to result from the potential introduction of specific alternative truck configurations. The total annual capital costs predicted ranged as high as \$8.5M (\$.085B over the ten year funding period) for the six-axle 98,000 lb. tractor-trailer.

In summary, there is a large range of disparity in the costs, scale, parameters, methods and purpose of previous studies, which makes a comparison between them and to the 2014 CTSW Study extremely difficult.

**2.1.6 List of References**

<b>Methods and Impacts of the Bridge Strength Limit State</b>			
<b>Reference No.</b>	<b>Document No.</b>	<b>Document Title and Link</b>	<b>Relevance to Study</b>
2.1.6-1	FHWA NHI 12-049	Bridge Inspector’s Reference Manual, BIRM <a href="http://www.fhwa.dot.gov/bridge/nbis/pubs/nhi12049.pdf">http://www.fhwa.dot.gov/bridge/nbis/pubs/nhi12049.pdf</a>	General Reference
2.1.6-2	TRB SR 267	Special Report 267: Regulation of Weights, Lengths, and Widths of Commercial Motor Vehicles, 2002 <a href="http://www.nap.edu/catalog.php?record_id=10382">http://www.nap.edu/catalog.php?record_id=10382</a>	CTSW
<p>This study follows a series of investigations of the regulation of commercial motor vehicle size and weight conducted by the U.S. Department of Transportation (DOT) and by earlier TRB committees. The study charge in TEA-21 asked TRB to take into account the conclusions of the 1990 report Truck Weight Limits: Issues and Options (TRB Special Report 225), which was also produced at the request of Congress. In 2000, DOT published the final version of its <b>Comprehensive Truck Size and Weight Study</b>; the TRB committee that conducted the present study interpreted its task as complementary to the DOT study. The objective of the latter study was to develop an analytical framework that could be applied to assess a range of policy options; the study did not generate policy recommendations.</p> <p>One of the findings of Report 267 was that “The methods used in past studies have not produced satisfactory estimates of the effect of changes in truck weights on bridge costs”. Instead, they have estimated the cost of maintaining the existing relationship of legal loads to bridge design capacity through bridge replacement strategies and they ignore other options state agencies may have in maintaining their bridges.” The study also recommended the authorization of pilot studies to better understand the impacts of the larger heavier trucks on the states’ infrastructure.</p>			
2.1.6-3		Western Uniformity Scenario Analysis, USDOT, 2004 <a href="http://www.fhwa.dot.gov/policy/otps/truck/wusr/wusr.pdf">http://www.fhwa.dot.gov/policy/otps/truck/wusr/wusr.pdf</a>	CTSW
<p>In 2000 the U. S. Department of Transportation (DOT) issued the Comprehensive Truck Size and Weight (CTS&amp;W) Study, the first such study by DOT since 1981. The CTS&amp;W Study analyzed five truck size and weight scenarios varying from a rollback of size and weight limits to nationwide operations of longer combination vehicles (LCVs). Due to time constraints, the scenario could not be included in the CTS&amp;W Study Volume III, but the Department agreed to analyze the scenario in a follow-up report.</p>			



<b>Methods and Impacts of the Bridge Strength Limit State</b>			
<b>Reference No.</b>	<b>Document No.</b>	<b>Document Title and Link</b>	<b>Relevance to Study</b>
	<p>All of the studies performed by the Federal Highway Administration (FHWA), the Transportation Research Board (TRB), and several universities in the last ten years that examined potential impacts of truck size and weight (TS&amp;W) increases have found that the estimated damage to bridges would be the greatest single infrastructure cost caused by larger, heavier trucks.</p> <p><i>This study uses the FHWA WINBasic tool to analyze bridges included in the Region. It uses the NBI to get basic geometry and material data. The tool uses estimated bridge dead-loads and live loads are computed based on the scenario trucks using operating and inventory load rating. This method may have been appropriate for 2004 however the means and methods would not be compliant with current AASHTO load rating requirements and regulations. The tool is only capable of recommending bridge replacements therefore the final impact cost would be at best the extreme high end or upper bound of cost and not representative of the most likely impact costs.</i></p>		
2.1.6-4	AASHTO 27-MBE-2-M	The Manual for Bridge Evaluation, 2nd Edition with interim updates to 2013; American Association of State Highway Transportation Officials <a href="https://bookstore.transportation.org/">https://bookstore.transportation.org/</a>	Load Rating, Posting
<p>This document provides guidelines, rules, and specifications for the inspection and load rating of existing bridges. Owner agencies are required to load rate each of their bridges at least biennially to assure they can carry legal loads. This document provides the basis for assessing the load capacity of these bridges by calculating allowable stresses and load factors, which are functions of the bridge material, age and condition.</p> <p><i>This will be used as the guiding document for the structural analysis, load rating and posting assessment of the bridges.</i></p>			
2.1.6-5	NCHRP Report 700 (12-78; 12-83)	Evaluation of Load Rating by Load and Resistance Factor Rating; Mark Mlynarski, Michael Baker, Modjeski & Masters, Work in Progress (Report 12-78 completed 2011; Report 12-83 in Progress) <a href="http://apps.trb.org/cmsfeed/TRBNetProjectDisplay.asp?ProjectID=1629">http://apps.trb.org/cmsfeed/TRBNetProjectDisplay.asp?ProjectID=1629</a> <a href="http://onlinepubs.trb.org/onlinepubs/nchrp/nchrp_rpt_700/Appendices.pdf">http://onlinepubs.trb.org/onlinepubs/nchrp/nchrp_rpt_700/Appendices.pdf</a>	Load Rating
<p>This report documents the analysis of 1,500 bridges that represent various material types and configurations using AASHTOWare™ Virtis® (Now AASHTOWare Bridge Rating, ABRr) to compare the load factor rating to load and resistance factor rating for both moment and shear induced by design vehicles, AASHTO legal loads, and eight additional permit/legal vehicles. The report includes recommended revisions to the AASHTO Manual for Bridge Evaluation based on a review of the analysis results.</p> <p>This is work in progress for developing load rating methods in LRFR format using a database of 18,000 bridges nationwide with actual load rating analysis on 1500 of those bridges. The purpose of this report is to make final recommendations for AASHTO’s Manual of Bridge Evaluations for methods and means of conducting load ratings in LRFR. As such, this is still a work in progress and no concrete resolutions have been made for changes to the manual, and in any case the recommendation will not be totally relevant to the current 2014 CTSW Study. However, it may be</p>			

<b>Methods and Impacts of the Bridge Strength Limit State</b>			
Reference No.	Document No.	Document Title and Link	Relevance to Study
		a good source for obtaining bridge files for analysis	
2.1.6-6	AASHTO 27-LRFDUS-6	LRFD Bridge Design Specifications, 6TH Edition 2011 <a href="https://bookstore.transportation.org">https://bookstore.transportation.org</a>	Load Rating, Design
		<p>The provisions of these specifications are intended to govern the design, evaluation and rehabilitation of bridges and is mandated by FHWA for use on all bridges. It employs the load resistance factor design (LRFD) methodology using factors derived from current statistical knowledge of all loads and structural performance.</p> <p>This will be used as the guiding document for the structural analysis, load rating and posting assessment of the bridges</p>	
2.1.6-7	AASHTO 27-HB 17	Standard Specifications for Highway Bridges, 17th Edition <a href="https://bookstore.transportation.org/">https://bookstore.transportation.org/</a>	Load Rating, Posting
		<p>This document provides guidelines, rules, and specifications for the design of new bridges and rehabilitation of existing bridges. Moreover it provides truck and lane design loads such H20 and HS20, wind, snow and seismic load combinations and factors for bridge design</p> <p>This will be used as a supplemental guiding document for the structural analysis, load rating and posting assessment of the bridges. The AASHTO defined rating trucks such as the H20 and HS20 are defined in this manual. These trucks will be used in the ABrR (VIRTIS) program and will be used in part as a basis for evaluating the bridges for their capacity to carry the existing fleet and the proposed future fleet of vehicles.</p>	
2.1.6-8	NCHRP SYN 453	NCHRP Synthesis 453: State Bridge Load Posting Processes and Practices, Transportation Research Board, George Hearn, University of Colorado at Boulder, 2014 <a href="http://onlinepubs.trb.org/onlinepubs/nchrp/nchrp_syn_453.pdf">http://onlinepubs.trb.org/onlinepubs/nchrp/nchrp_syn_453.pdf</a>	Load Rating, Posting
		<p>This report is a synthesis of the practices of U.S. state governments in restricting weights of vehicles that can cross highway bridges and culverts. Bridges and culverts restricted for vehicle weights are called load posted structures. The load posting practices of bridge owners include the identification of structures to post for load, the evaluation of safe load capacities of these structures, and the implementation of restrictions on vehicle weights at structures.</p> <p>Practices for load posting operate within a system of legal loads established in law and regulation of federal, state, and local governments. Posting for load is one possible outcome of states' greater activities in evaluation of safe load capacities of bridges and culverts. States post for load, but also grant permits that allow overweight vehicles to travel on designated routes. Overall, states identify and regulate routes that can carry overweight vehicles, routes that can carry legal weight vehicles only, and routes or individual structures that must be restricted to less than legal loads.</p> <p><i>The LRFR method adopted in the 2014 CTSW Study by necessity eliminates the need to refer to individual state policies and practices with regard to posting vulnerable bridges. All LRFR bridge ratings were normalized to the Base Case Control Trucks. Normalized rating factor values less than 1.0 indicated that there was a posting issue for that representative bridge and the class of bridges of that type.</i></p>	

<b>Methods and Impacts of the Bridge Strength Limit State</b>			
Reference No.	Document No.	Document Title and Link	Relevance to Study
	<i>In the final analysis, each state agency or bridge owner have to structurally analyze their bridges in accordance with AASHTO and their state regulations to determine if posting is required.</i>		
2.1.6-9	NCHRP RPT 575	NCHRP Report 575: Legal Truck Loads and AASHTO Legal Loads for Posting, Transportation Research Board, Bala Sivakumar, Lichtenstein Consulting Engineers, Inc., 2006 <a href="http://onlinepubs.trb.org/onlinepubs/nchrp/nchrp_rpt_575.pdf">http://onlinepubs.trb.org/onlinepubs/nchrp/nchrp_rpt_575.pdf</a>	Load Rating
	<p>Summary: In the US trucks are allowed unrestricted operation on the nations highways' and are generally considered legal provided they meet the weight guidelines of the Federal Bridge Formula B (FBF), up to 80,000 lbs. GVW and if any single axle load does not exceed 20,000 lbs. Tandem axles cannot exceed 34,000 lbs. (Each state has additional guidelines and restrictions.) The current AASHTO truck design loads consisting of the H20 and HS20 family of trucks do not adequately represent the fleet of trucks that operate in the United States. It has been found that on certain bridges, the FBF compliant trucks may overstress those bridges by as much as 22%. One of the goals of Report 575 was to investigate through state surveys and WIM data a representative set of trucks that would more adequately represent the class of trucks that are currently operating and attempt to formulate new design guidelines. Other goals as stated in the report included the provision of load factors for use with the LRFD method of design and the LRFR method of load rating.</p> <p>The NCHRP Report 575 goes to the heart of the CTSW study as it relates to structural impacts on bridges and load postings. It was designed to answer the question of "what is the structural effect of the current fleet of legal vehicles on the nation's bridges?" However, the report only answers this question on "a set of generic spans". The results and findings of this study could not be wholly inclusive of Steel Trusses, and Girder Floorbeam type spans.</p>		
2.1.6-10	FHWA-PD-96-001	Recording and Coding Guide for the Structure Inventory and Appraisal of the Nation's Bridges; 1995; Office of Engineering, Bridge Division	Bridge Inventory, NBIS
	This Guide has been prepared for use by the States, Federal and other agencies in recording and coding the data elements that will comprise the National Bridge Inventory data base. By having a complete and thorough inventory, an accurate report can be made to the Congress on the number and state of the Nation's bridges. The Guide also provides the data necessary for the Federal Highway Administration (FHWA) and the Military Traffic Management Command to identify and classify the Strategic Highway Corridor Network and it's connectors for defense purposes.		
2.1.6-11	<b>Idaho</b>		
		<i>129,000 Pound Pilot Project: Report to the 62nd Idaho State Legislature.</i> Idaho Transportation Department, January 2013. <a href="http://itd.idaho.gov/newsandinfo/Docs/129000%20Pound%20Pilot%20Project%20Report.pdf">http://itd.idaho.gov/newsandinfo/Docs/129000%20Pound%20Pilot%20Project%20Report.pdf</a>	Truck Size & Weight Study
	This study quantifies damages based on NBI ratings before, during, and after the study for several different categories of bridges. This study does not consider the shift in modes of transport, or comment on the effects on other routes not included in the scope.		
2.1.6-12	<b>Indiana</b>		

<b>Methods and Impacts of the Bridge Strength Limit State</b>			
Reference No.	Document No.	Document Title and Link	Relevance to Study
	FHWA/IN/JT RP-2007/10	Long-Term Effects of Super Heavy-Weight Vehicles on Bridges; <a href="http://docs.lib.purdue.edu/jtrp/236/">http://docs.lib.purdue.edu/jtrp/236/</a>	Permitted Truck Study
<p><b>Abstract:</b> A permit truck which exceeds the predefined limit of 108 kips is defined as a superload in Indiana. This study was conducted to examine the long-term effects of superload trucks on the performance of typical slab-on-girder bridges and to assess the likelihood of causing immediate damage. Typical steel and pre-stressed concrete slab-on-girder type bridges were analyzed using both beam line analysis and detailed finite element models.</p>			
2.1.6-13	FHWA/IN/JT RP-2010/12	A Synthesis of Overweight Truck Permitting; <a href="http://docs.lib.purdue.edu/jtrp/1118/">http://docs.lib.purdue.edu/jtrp/1118/</a>	
<p>For purposes of safety and system preservation, trucking operational characteristics are regulated through legislation and policies. However, special permits are granted for trucks to exceed specified operational restrictions. Thus, the Indiana DOT not only seeks highway operations policies that retain/attract heavy industry including those that haul large loads but also seeks to protect the billions of taxpayer dollars invested in highway infrastructure. As such, “it is sought to avoid policies that may lead to premature and accelerated deterioration of assets through excess loading or undue safety hazard through oversize loads. ... “Using data from a national study, the report quantifies the extent to which each additional payload increases pavement deterioration. The data also suggests that having more axles on a truck reduces pavement deterioration and consequently, damage repair cost, but could decrease the revenue to be derived from overweight permitting. In conclusion, the study recommended the conduction of a cost allocation study to update these load-damage relationships as well as the overweight permit fee structures, to reflect current conditions in Indiana.</p>			
2.1.6-14	FHWA/IN/JT RP-2011/15	Evaluation of Effects of Super-Heavy Loading on the US-41 Bridge over the White River <a href="http://docs.lib.purdue.edu/jtrp/1491/">http://docs.lib.purdue.edu/jtrp/1491/</a>	Super Loads, Fatigue
<p>Built in 1958, the US-41 White River Bridge is a two-girder, riveted steel structure located in Hazelton, IN. The bridge is comprised of two, sixteen span superstructures sharing a common substructure. Each superstructure also contains four pin and hanger expansion joint assemblies. Long-term remote monitoring was used to quantify any negative effects due to the series of superloads. Five primary tasks were undertaken as part of this study:</p> <ol style="list-style-type: none"> <li>1. Perform controlled load testing to gain insight on the typical behavior of the bridge.</li> <li>2. Monitor the effect of individual superloads on the bridge structure to detect any notable damage.</li> <li>3. Perform an in-depth fracture critical evaluation.</li> <li>4. Evaluate the effects of multiple super-heavy loading events on the bridge.</li> <li>5. Collect stress range histograms to be used as part of a fatigue life evaluation</li> </ol>			
2.1.6-15	<b>Louisiana</b>		
	LTRC_398	Effects of Hauling Timber, Lignite Coal and Coke Fuel on Louisiana Highways and Bridges, LTRC Report No. 398. Roberts, Freddy L.; Saber, Aziz; Ranadhir, Abhijeet; Zhou, Xiang. USDOT. March 2005. <a href="http://www.ltrc.lsu.edu/pdf/2005/fr_398.pdf">http://www.ltrc.lsu.edu/pdf/2005/fr_398.pdf</a>	Truck Study, Load Demands

<b>Methods and Impacts of the Bridge Strength Limit State</b>			
Reference No.	Document No.	Document Title and Link	Relevance to Study
		<p>This study provides a report on the performance of simple span as well as three span bridges of varying lengths. The performance is examined based on the ratios of maximum moment and shear of the exclusion vehicle compared to that of the bridge design vehicle. The sample bridges selected were designed with either H15 or HS20 truck loads. An in depth fatigue evaluation was not performed for this study. Instead the bridge life was determined using a simplified formula involving the performance ratio that was calculated. The added costs for these heavy trucks was then determined using the calculated bridge life.</p>	
2.1.6-16	<b>Maine</b>		
		<p>Engineering Analysis of Maine's Interstate Bridges, 100,000 Pound Six Axle Trucks, 2011 Sweeney, Kenneth L.; Getchell, Chip;  <a href="http://www.maine.gov/mdot/docs/EngineeringAnalysis-of-MaineInterstateBridges8-15-11.pdf">http://www.maine.gov/mdot/docs/EngineeringAnalysis-of-MaineInterstateBridges8-15-11.pdf</a></p>	Truck Size & Weight Study
	<p>In December 2009, the United States Congress authorized a one year Pilot Program that allowed Maine (and Vermont) to use State weight limits on the Interstate instead of the Federal cap of 80,000 pounds. Through two Executive Orders and then State legislation, Governor Baldacci and the Maine Legislature modified State law to allow a three-axle truck-tractor with a three-axle semi-trailer at 100,000 pounds to use Maine's entire Interstate system, effectively diverting large trucks from non-Interstate highways to the Interstate. Previously, this configuration was only authorized on the Maine Turnpike.</p>		
2.1.6-17		<p>Interstate Highway Truck Weights – White Paper; Prepared by Maine DOT; September 20, 2010  <a href="http://www.maine.gov/mdot/truckweights/documents/pdf/MaineDOTTruckWeightPaper091020.pdf">http://www.maine.gov/mdot/truckweights/documents/pdf/MaineDOTTruckWeightPaper091020.pdf</a></p>	CTSW Web Site, Truck Size & Weight Study, Safety
	<p>In Maine, 100,000-pound six-axle semi-trailers have long been allowed to operate on approximately 22,500 miles of non-Interstate highways in the state. These same vehicles are unable to operate on approximately 250 miles of Maine's 367 miles of Interstate highways. This situation forces these semi-trailers to exit the controlled-access Interstate system and travel on secondary roads with numerous villages, intersections, driveways, schools, crosswalks and many other potential conflict points</p>		
2.1.6-18	Executive Summary, Final Report , Appendices	<p>Study of Impacts Caused by Exempting the Maine Turnpike and New Hampshire Turnpike from Federal Truck Weight Limits; June 2004; Wilbur Smith Associates  <a href="http://www.maine.gov/mdot/ofbs/documents/pdf/Non20Exempt20Final20Report.pdf">http://www.maine.gov/mdot/ofbs/documents/pdf/Non20Exempt20Final20Report.pdf</a></p>	Truck Size & Weight Study
	<p><b>Abstract:</b> Regulations governing truck size and weight have impacts on highway safety, infrastructure preservation and economic efficiency. In the United States (U.S.), federal laws govern truck size and weight (TS&amp;W) on the Interstate Highway System. Federal TS&amp;W laws are of particular importance to U.S. border-states heavily impacted by the North American Free Trade Agreement. Nearly all this trade travels by truck. Both Canada and Mexico allow significantly higher truck weight limits in their respective counties. As a result, U.S. companies competing against cross-border rivals in natural resource based industries, where profit margins are typically low find it difficult to compete against foreign competition that is able to use more efficient</p>		

<b>Methods and Impacts of the Bridge Strength Limit State</b>			
Reference No.	Document No.	Document Title and Link	Relevance to Study
	means of transportation.		
2.1.6-19	Position Paper	Impact and Analysis of Higher Vehicle Weight Limits on Minnesota Interstate System; March 2011; Minnesota DOT <a href="http://transportationproductivity.org/templates/files/minnesota-dot.pdf">http://transportationproductivity.org/templates/files/minnesota-dot.pdf</a>	CTSW Web Site, Truck Size & Weight Study
	<p>Mn/DOT's Minnesota Truck Size and Weight Project (June, 2006) established Mn/DOT's position with regard to heavier trucks. The study views the topic from a standpoint of balancing infrastructure preservation, safety and economic benefits. Several neighboring states in the upper Midwest and Canada have higher vehicle weight limits than Minnesota. Many agricultural industries in Minnesota are impacted competitively by lower vehicle productivity in Minnesota. Current Truck Size and Weight limits (80,000 pounds on Interstate system) control the amount of payload that can be carried in a truck. An increase in vehicle weight limits would increase the allowable weight per trip, so fewer truck trips would be necessary to carry the same weight. Freight transportation cost savings due to increases in vehicle weight limits would benefit not only shippers and carriers but all consumers.</p> <p>There are two current bills in Congress (HR 763 and HR 801) that proposes increasing vehicle weight limits of vehicles using the national interstate system. These bills both display "opt-in" language, meaning that enabling State legislation is a requirement of the proposed law.</p> <p><i>This paper was cited in the CTSW Web Site in light of the bridge study. Many bridges on the interstate system would potentially be impacted by this legislation.</i></p>		
2.1.6-20	FR2	Minnesota Truck Size and Weight Project Final Report; 2006; Cambridge Systematics <a href="http://www.dot.state.mn.us/information/truckstudy/pdf/trucksizeweightreport.pdf">http://www.dot.state.mn.us/information/truckstudy/pdf/trucksizeweightreport.pdf</a>	Truck Size & Weight Study
	<p>This report summarizes the approach, findings, and recommendations of the Minnesota Truck Size and Weight (TS&amp;W) Project led by the Minnesota Department of Transportation (Mn/DOT) in cooperation with other public and private stakeholders. The purpose of the project is to assess changes to Minnesota's TS&amp;W laws that would benefit the Minnesota economy while protecting roadway infrastructure and safety.</p>		
2.1.6-21	<b>Texas</b>		
	FHWA/TX-10/0-6095-1; FHWA/TX-10/0-6095-2	Potential Use of Longer Combination Vehicles in Texas: First & Second Year Reports (multiple documents); <a href="ftp://ftp.dot.state.tx.us/pub/txdot-info/rli/psr/0-6095.pdf">ftp://ftp.dot.state.tx.us/pub/txdot-info/rli/psr/0-6095.pdf</a>	Truck Study, LCV
<p>Trucking remains the only major freight mode not to benefit from increases in size and weight regulations since 1982. The need for more productive trucks—both longer (LTL) and heavier (TL)—is growing with economic activity, rising fuel costs and concerns over environmental impacts from emissions. This study covers the first year activities of a two-year TXDOT-sponsored study into potential LCV use in Texas. It describes current U.S.LCV operations and regulations, operational characteristics of various LCV types, safety issues, and environmental and energy impacts, together with pavement and bridge consumption associated with LCVs. Methods to measure both pavement and bridge impacts on a route basis are described. A survey of current U.S. LCV operators provides an insight into business characteristics, vehicles, drivers, performance, and safety. The overall study benefited from three sources of direction: an advisory</p>			

<b>Methods and Impacts of the Bridge Strength Limit State</b>			
<b>Reference No.</b>	<b>Document No.</b>	<b>Document Title and Link</b>	<b>Relevance to Study</b>
		panel from TXDOT, an industry panel comprising heavy truck and LCV operators, and finally an academic team from the University of Michigan Transportation Research Institute. In the second year of the study, a series of routes and LCV types will be evaluated in Texas using methods developed in the first year and approved at a study workshop.	
2.1.6-22	<b>Maine and Vermont – multiple studies</b>		
	ME_VT_Pilot – 6 month Report; Vermont Final Report	<b>Maine and Vermont Interstate Highway Heavy Truck Pilot Program- 6-Month Report</b> , Congressional Reports, Multiple Documents; Maine and Vermont Pilot Program Congress Report. The Report was prepared by a team of Federal and State Agencies (VDOT, MeDOT); December 2010 <a href="http://ops.fhwa.dot.gov/freight/sw/reports/me_vt_pilot_2012/">http://ops.fhwa.dot.gov/freight/sw/reports/me_vt_pilot_2012/</a>	Truck Size & Weight; Fatigue
	<p>Section 194 of the Consolidated Appropriations Act, 2010 (Public Law (P.L.) 111-117), directs the Secretary of Transportation to study the impacts of the Maine and Vermont truck pilot programs, which replace Federal commercial-vehicle weight regulations with State limits on Interstate highways in those States. Public Law 111-117 also exempts Maine and Vermont from following Federal Bridge Formula B requirements mandated by Section 127 of Title 23, United States Code.</p> <p><b>Abstract:</b> The purpose of this initial assessment is to report “...to the House and Senate Committee on Appropriations no later than six months after the start of the pilot program on the impact to date of the pilot program on bridge safety and weight impacts.” Accordingly, this report presents the findings of the U.S. Department of Transportation (DOT) analysis which focuses on bridge safety and pavement performance. It discusses truck size and weight regulations in Maine and Vermont prior to and after passage of P.L. 111-117 and provides the most recent weigh-in-motion, registration, and permit data. The report also summarizes the findings of previous truck size and weight studies and highlights methodologies used to determine bridge load and operating ratings.</p> <p>The <b>Final report</b> was a continuation of the findings in the earlier 6-month report, but it also included steel fatigue study on a sampling of bridges. It concluded that the pilot trucks would have little cost and structural impacts on Vermont’s network of Interstate bridges. <i>See the Final Report reference under the Vermont Truck Size &amp; Weight Study</i></p>		
2.1.6-23	<b>West Virginia</b>		
		An Analysis of Truck Size and Weight FOR WVDOT. ( <a href="mailto:ksowards@njrati.org">ksowards@njrati.org</a> ) Appalachian Transportation Institute, Marshall University, Huntington WV <a href="http://www.njrati.org">http://www.njrati.org</a>	Truck Size & Weight Study; Cost Allocation
	<p><b>Abstract:</b> A gap in the body of knowledge in the areas of cost allocation/infrastructure recovery and safety regarding increases in truck size and weight has been identified. The goal of this research is to critically evaluate the claims made by groups advocating for heavier and longer trucks and to update knowledge potential impacts to safety and infrastructure, including economic and fiscal consequences. Given that a Congressionally mandated study will be conducted over the next two years, the focus will be on completing this research effort to supplement the work that is being done by the Federal Highway Administration. The study will be divided into three main areas: safety, infrastructure, and cost recovery</p>		

<b>Methods and Impacts of the Bridge Strength Limit State</b>			
Reference No.	Document No.	Document Title and Link	Relevance to Study
2.1.6-24	<b>Wisconsin</b>		
		<p><i>2009 Wisconsin Truck Size and Weight Study</i>. Multiple documents. Wisconsin Traffic Operations and Safety Laboratory. Cambridge Systematics and Department of Civil and Environmental Engineering: University of Wisconsin-Madison. Available at <a href="http://www.topslab.wisc.edu/workgroups/wtsws.html">http://www.topslab.wisc.edu/workgroups/wtsws.html</a></p>	Truck Size and Weight Study
<p>This is a valuable study that considers the inclusion of six new heavy truck configurations. Study focuses on the inclusion of these configurations on both state highways as well as the combination of both state and federal highways. The Study does look into several of the other areas that need to be addressed with heavier trucks including permitting and safety; however the evaluation of potential changes to shipping modes is lacking full attention. This is seen in the study's examination of rail-to-truck diversion. This portion of the study lack concrete data and partially relied on expert opinion.</p>			
2.1.6-25		<p>Bloomberg- "Kraft Pushes for 97,000-Pound Trucks Called Bridge Wreckers" J. Plungis. Bloomberg.com, December 2011. <a href="http://www.bloomberg.com/news/2011-12-12/kraft-leads-push-for-97-000-pound-trucks.html">http://www.bloomberg.com/news/2011-12-12/kraft-leads-push-for-97-000-pound-trucks.html</a></p>	Truck Size and Weight Study
	<p>Emboldened by U.S. legislation allowing Maine and Vermont to keep 97,000-pound trucks rumbling on their interstate highways, Kraft Foods Inc. and Home Depot Inc. are pressing more states to follow. Companies including Kraft, which says its trucks would drive 33 million fewer miles a year with higher weight limits nationwide, say they need to carry loads more efficiently to combat high diesel-fuel prices. Safety advocates say more heavy trucks would accelerate an increase in truck-related accident deaths, and question whether bridges can withstand the added weight.</p> <p><i>This was another article sighted by the CTSW web site regarding trucks with GVW over the Federal Limits. It is included here for informational purposes and for understanding issues in general regarding overweight/oversize trucks as perceived by the public.</i></p>		
2.1.6-26	NCHRP 20-07 (303)	<p>Directory Of Significant Truck Size And Weight Research; Jodi L. Carson, P.E., Ph.D. ; Texas Transportation Institute; Texas A&amp;M University System ; October 2011</p>	Truck Size & Weight Study
	<p><i>A Directory of Significant Truck Size and Weight Research</i> was to provide a brief, well organized summary of significant research related to large truck size and weight for use by decision-makers. In particular, this reference document will benefit those involved in considering possible changes in regulations related to truck size and weight limits. This <i>Directory</i> is intended to address the breadth of all related topic areas and consider research performed by various sponsoring agencies but is not intended to be inclusive of all related research. Instead, this reference guide will be limited to only that related research that is considered to be relevant, significant, and useful.</p> <p><i>This is a significant document in that it emulates the elements of the current CTSW underway</i></p>		
2.1.6-27	NCHRP 20-68A, Scan 12-01	<p>Advances in State DOT Superload Permit Processes and Practices; NCHRP Project 20-68A U.S. Domestic Scan, April 2014</p>	Superload Permits
<p>In addition, for documents referencing Methods and Impacts of Bridge Strength Limit State see</p>			



<b>Methods and Impacts of the Bridge Strength Limit State</b>			
<b>Reference No.</b>	<b>Document No.</b>	<b>Document Title and Link</b>	<b>Relevance to Study</b>
		“Reference Nos.”: 2.2.7-17; 2.2.7-18; 2.3.6-32; 2.3.6-46; 2.3.6-47	

## **2.2 Documents on Methods and Impacts of the Bridge Fatigue Limit State**

### **2.2.1 Introduction**

Load induced fatigue has been observed in steel components for over 140 years. The modern day approach to fatigue design of fabricated steel structures was primarily developed during the 1960s and 1970s. This research identified the following major factors impacting fatigue life: stress range, stress cycles, and steel fatigue details. The current code approach is based upon Miner’s linear damage rule concerning the cumulative process of fatigue and the determination of stress range as it relates to the stress-life approach. The evaluation of fatigue effects of overweight trucks requires either calculating the effective stress range at the un-cracked details of concern or utilizing site specific stress measurements under the fatigue truck. The overall desk scan on fatigue studies is summarized as follows:

### **2.2.2 A survey of analysis methods and synthesis of the state of the practice in modeling Fatigue Impact**

#### ***2.2.2.1 History of steel fatigue study and development***

AASHTO published the first fatigue design provisions in 1965. They were completely revised in the 1977 AASHTO Highway Bridge Design Standard Specification, 12th Edition, based on the research results of Dr. John Fisher of Lehigh University and his colleagues. Many specification changes associated with specific details were incorporated annually by AASHTO to improve design as well as fabrication and field performance, however the S-N approach remained unchanged. In 1994 the introduction of the AASHTO LRFD Bridge Design Specification incorporated a reliability-based approach with significant changes to the load models for fatigue design.

#### ***2.2.2.2 - State of the Practice in modeling load induced fatigue effect in steel bridges***

##### ***2.2.2.2.1 - AASHTO Specifications for fatigue design and evaluation***

The AASHTO Highway Bridge Standard Specifications and AASHTO LRFD Bridge Design Specifications are referred to for fatigue analysis. Even though the load models are different in these two specifications, the classification of fatigue details, detail illustrative examples, and fatigue detail resistance (Constant Amplitude Fatigue Threshold (CAFT)) remain essentially unchanged. CAFT is a stress range or limit state below which an applied, constant stress range will not create fatigue damage and for which the detail will theoretically have infinite life. A structure rarely experiences a constant stress range. Therefore, the calculated stress range due to site specific data shall be considered to be below half of the CAFT or the variable amplitude fatigue threshold (VAFT) in order to ensure no fatigue damage and to theoretically experience

infinite fatigue life for the detail being considered. If the particular detail of concern fails to achieve these thresholds, a more complex finite life fatigue evaluation is required.

For estimating the remaining fatigue life in bridges, the AASHTO Manual for Condition Evaluation and LRFR of Highway Bridges, and the AASHTO Guide Specifications for Fatigue Evaluation of Existing Steel Bridges, have been widely used.

#### 2.2.2.2.2 - Bridge Modeling Methods

Three modeling methods have been commonly used in previous studies as follows:

1. 2D beam model: in this method, the bridge is only modeled in the longitudinal direction and steel stringers are modeled as beam elements. Effects in the transverse direction are considered by utilizing AASHTO's live load distribution factors.
2. 3D beam model: in this method, bridge components including the deck and stringers are modeled as beam elements in both the longitudinal and transverse directions.
3. 3D Finite element model: in this method, more complex elements such as plate element, shell element, etc. are used to model a bridge.

#### 2.2.2.3 *Distortion Induced Fatigue Study*

Distortion induced fatigue is due to secondary stresses in the steel connection plates that comprise bridge member cross sections. Typically, the effects of secondary stresses are seen at the connections to primary members. However, distortion induced steel fatigue cannot be codified. And methods for prediction of secondary stresses are not specifically addressed by the AASHTO specifications. Analysis of distortion induced fatigue requires a detailed Finite-Element model for the specific bridge being considered. Accordingly, limited studies have been focused on using finite-element modeling to determine the magnitude of distortion-induced stresses, to describe the behavior of crack development, and to assess the effectiveness of repair alternatives. Importantly, the results indicate severe stress concentration at the crack initiation sites, and typically a low cycle fatigue phenomenon.

#### 2.2.2.4 *Fatigue Study on Concrete, reinforcement and pre-stressed concrete strands*

AASHTO generally does not specify the investigation of fatigue in concrete decks, considering decks of greater than 9" thickness to have infinite fatigue life. However, decks constructed prior to the 1960s with thickness less than 9 inches or with girder spacing greater than 10 ft may be susceptible to longitudinal flexural cracking which could decrease their service life.

With respect to fatigue in rebar and pre-stressed concrete strands; there is increasing interest and several significant studies including perhaps most notably: The 2003 Minnesota DOT / University of Minnesota study entitled 'Effects of Increasing Weight on Steel and Pre-stressed Bridges' (Section 2.2.5 -1), and the 2013 South Carolina study titled the 'Rate of Deterioration of Bridges and Pavements as Affected by Trucks'. The South Carolina study referenced the following publications as resources:

- Altay, A.K., Arabbo, D.S., Corwin, E.B., Dexter, R.J., French, C.E. (2003)

Effects of Increasing Truck Weight on Steel and Pre-Stressed Bridges, Minnesota Department of Transportation, University of Minnesota.

- Bathias, C., and Paris, P. C., (2005) Gigacycle Fatigue in Mechanical Practice, Marcel Dekker, New York.
- Chowdury, M., Putnam, B., Pang, W., Dunning, A., Dey, K., Chen, L., (2013)
- Rate of Deterioration of Bridges and Pavements as Affected by Trucks, SPR 694, Columbia, South Carolina.
- Helgason, T., Hanson, J. M., Somes, N. F., Corley, W. G., and Hognestad, E., (1976) Fatigue Strength of High-Yield Reinforcing Bars, NCHRP Report 164, Transportation Research Board, National Research Council, Washington D.C.
- Overman, T. R., Breen, J. E., and Frank, K. H., (1984) Fatigue Behavior of Pretensioned Concrete Girders, Center for Transportation Research, University of Texas at Austin, Austin, Texas.
- Paulson, C., Frank, K. H., Breen, J. E., (1983) A Fatigue Study of Pre-stressing Strand, Center for Transportation Research, University of Texas at Austin, Austin, Texas.

The South Carolina study in particular provides a significant amount of data on their 9,271 bridges with respect to truck impacts measured with the fatigue limit state as an indicator of relative bridge damage.

### **2.2.3 An identification of data needs and an evaluation and critique of available data sources**

#### ***2.2.3.1 Data needs - Bridge data and fatigue truck data***

In order to perform fatigue analysis of overweight truck effects, specific bridge data and truck data are needed. In general, bridge data can be obtained through record drawings to meet the research needs. Typically information in the NBI database is not sufficient to build a bridge model. For truck data, both AASHTO LRFD and Standard specifications (17th Edition) use the 72,000 lb. HS-20 truck as the fatigue truck to represent the large variety of actual trucks of different configurations and weights. The fatigue truck has a constant dimension of 30' between main axles of 32,000 lb. This arrangement approximates the 4 and 5 axle trucks that do most of the fatigue damage to bridges. In previous overweight truck and fatigue studies, various overweight trucks up to 119,000 lb. GVW, were analyzed as fatigue loads. For example, research in Louisiana limited truck GVW to 100,000 lbs., and research in Indiana used trucks ranging in GVW from 54,400 lb. for Class 9 vehicles to 119,500 lb. for Class 13 vehicles. In some cases, Strains measured in the field have also been used to calibrate stress ranges obtained from analysis and modeling.

#### ***2.2.3.2 Critique of available data sources***

- The fatigue mechanism has been extensively researched and S<sub>N</sub> curves were developed primarily based on fatigue test data derived by Dr. John Fisher and his colleagues under constant amplitude cycle loading.
- Previous studies on overweight truck effects have primarily been a product of state sponsored research using limited WIM data in accordance with the state's needs. There

hasn't been a uniform standard for overweight trucks used for the fatigue studies across the nation.

- The results of previous studies are not consistent. For example, the 1983 “Steel Bridge Members under variable amplitude, long life fatigue loading” study, by Dr. Fisher, et al. concluded that the results obtained from variable amplitude tests were consistent with the previously reported constant amplitude test. However, NCHRP Report 721 ‘Fatigue Evaluation of Steel Bridges’ stated that “the S-N curve development based on constant amplitude stress range testing results is different from that derived from variable amplitude test data, because the latter involves a new dimension of uncertainty associated with the load effect”. The authors did not elaborate on the difference in the report, but mentioned that the Eurocode and the Australian code both use multiple slopes instead of a single slope developed based on the constant amplitude stress range testing results.

### **2.2.4 An assessment of the current state of the understanding of the impact and needs for future research, data collection and evaluation**

#### ***2.2.4.1 Assessment of the current state of the understanding of the impact***

Load induced fatigue in steel bridges was extensively studied in the 1970s and developed into the current AASHTO standards. Specifically, bridge connection details are grouped into categories A to E' based on their level of fatigue strength/resistance. Based on Dr. Fisher's study, the 5 ksi stress range represents an approximate upper bound of stress ranges observed on actual bridges. The majority of the stress ranges observed on actual bridges have been between 1 ksi and 3 ksi. The expected stress cycles on most bridges are between 10 million and 150 million. Through damage accumulation analysis, it was found that actual truck traffic closely correlates the effects of the fatigue design truck and that heavy traffic will not cause severe fatigue problems on steel girders with fatigue details of categories A, B and C. The AASHTO LRFD Design Specifications C6.6.1.2.3 state that “Experience indicates that in the design process the fatigue considerations for Detail Categories A through B' rarely, if ever, govern”. The S-N curves for fatigue detail categories D through E' are within this area of greater concern. This observation is consistent with experience in that fatigue failure has not been reported for categories A through C, but has occurred in categories D, E and E'.

It was also found that factors influencing the level of fatigue damage caused by a given vehicle are axle weights and spacing. In general, state specific overweight truck studies have been performed in accordance with AASHTO specifications and guidance, plus field strain measurement. These studies did not distinguish the impact and passing cycles of trucks of specific types or axle weights and configurations, therefore they were not configured to answer the questions the 2014 CTSW Study is intending to address.

#### ***2.2.4.2 Need for future data collection and research***

The following areas of further study are recommended in order to better understand and quantify the fatigue life impacts due to load induced fatigue in steel bridges:

- Further study using WIM data and strain values on multiple bridge types and fatigue category details in heavy load corridors to more definitively predict long term fatigue behavior under low magnitude and variable amplitude cycle loading.
- Calibration of S-N curves for the potential new fleets under variable amplitude cycle loading on steel bridges.
- Further study of fatigue behavior on concrete and pre-stressed concrete bridges of varying span lengths and support fixity under low magnitude and variable amplitude cycle loading.

**2.2.5 A synthesis of quantitative results of past studies with past prospective and retrospective estimates in each category of effect, including reasonable ranges of values for impact estimates**

1. Results of 2003 Minnesota DOT “Effects of Increasing Truck Weight on Steel and Pre-stressed Bridges”, (Altay et al., 2003). This study evaluated the effects of increasing the legal truck weight by 10 or 20% on 5 steel girder bridges and three pre-stressed I-girder bridges that were instrumented. It was discovered that: (1) Fatigue is insensitive to loading that occurs less frequently than 0.01% of all load cycles; (2) an increase in truck weight of 20% would lead to a reduction in the remaining life in their older steel bridges of up to 42% and a 10% increase would lead to a 25% reduction in fatigue life; (3) typical Minnesota pre-stressed concrete girders and concrete decks were found not to be susceptible to fatigue for truck weights increased by 20%.
2. Results of 2005 Wang et al. “Influence of Heavy Trucks on Highway Bridges”: it was observed that: (1) traffic induced flexural stress does not necessarily increase with Gross Vehicle Weight (GVW), but is highly related to axle weights and configurations; (2) there was very little difference in maximum strain (and stress) ranges induced by a 5 axle 80,000 lb. truck and the 134,000 lb. 9 and 11 axle trucks. The 5 axle 80,000 lb. truck did however produce the largest maximum strain range.
3. Results of 2006 FHWA “Fatigue of older Bridges in Northern Indiana due to Overweight and Oversized Loads” indicated that less than 1 percent of the trucks induce a strain range that exceeds the variable amplitude fatigue limit of the fatigue critical details in the structures in spite of heavy loads (more than 200,000 lbs) being carried.
4. Results of 2008 FHWA “Monitoring System to determine the impact of Sugarcane Truckloads on Non-Interstate Bridges” indicated the estimated fatigue cost is \$11.75 per trip per bridge for a 120,000 lb. GVW truck and \$0.90 per trip per bridge for a 100,000 lb. GVW truck.
5. Results of 2013 LTRC “Load Distribution and Fatigue Cost Estimates of Heavy Truck Loads on Louisiana State Bridges” indicated that if bridges are exposed to high cycles of repetition of heavy loads, the life span of the bridges will be reduced by about 50%.

Of the previous studies reviewed, only the 2003 Minnesota DOT “Effects of Increasing Truck Weight on Steel and Pre-stressed Bridges” study evaluated the effects of increasing the legal

truck weight on fatigue detail categories E and E'. But this study was limited to (presently) legal trucks of up to 66 kips GVW. The 2013 SCDOT Final Report of the 'Rate of Deterioration of Bridges and Pavements as Affected by Trucks', conducted jointly with Clemson University, was based on a finite element analysis of four 'archetypal' concrete bridge types in response to typical truck types determined to best represent the existing fleet based on WIM data analysis. It focused on fatigue in steel rebar and pre-stressed strands in slabs and beams respectively, concrete being the by far the most prevalent material type in South Carolina bridges. The following table compares these two studies to the 2014 CTSW Study.

**Major Fatigue Study Results**

Study	2003 Minnesota DOT Study	2013 SCDOT Study	2014 CTSW Study
<b>Fatigue Trucks</b>	<ul style="list-style-type: none"> <li>• 54 kip Truck (HS15)</li> <li>• 58 kip Truck</li> <li>• 66 kip Truck</li> </ul>	<ul style="list-style-type: none"> <li>• Multiple axle groups of 2 through 8 axles, with range of axle weights reflecting WIM data analysis</li> </ul>	<ul style="list-style-type: none"> <li>• 3S2-80 kip Truck</li> <li>• 3S2-88 kip Truck</li> <li>• 3S3-91 kip Truck</li> <li>• 3S3-97 kip Truck</li> <li>• 2S1-2-80 kip Truck (28.5' trailer)</li> <li>• 2S1-2-80 kip Truck (33' trailer)</li> <li>• 2S1-2-2 105.5 kip Truck</li> <li>• 3S2-2-2-129 kip Truck</li> </ul>
<b>Bridge Data</b>	<ul style="list-style-type: none"> <li>• 4 span continuous (Category E')</li> <li>• 3 span continuous (Category E)</li> <li>• Multiple span continuous plate girder (Category C)</li> <li>• 2 span continuous (Category E')</li> </ul>	<ul style="list-style-type: none"> <li>• Reinforced concrete slab, 33 ft. span</li> <li>• Pre-stressed: Conc. beam, &lt; 66' span; Conc. Beam, 66' to 115'; Conc. Beam, 115' to 148'</li> </ul>	<ul style="list-style-type: none"> <li>• Short span (42') simply supported bridge (Category E')</li> <li>• Long span (133') simply supported bridge (Category E)</li> <li>• 3 span continuous bridge (Category E)</li> <li>• 5 span continuous bridge (Category E)</li> </ul>
<b>Results</b>	<ul style="list-style-type: none"> <li>• Bridges that did not have E or E' details had infinite fatigue lives under all situations including a 10% increase in truck weight; bridges with category D or better details and with connection plates attached to both flanges are not as susceptible to fatigue.</li> <li>• An increase in truck weight of 20% would lead to a reduction in the remaining life in these older steel bridges</li> </ul>	<ul style="list-style-type: none"> <li>• "A 10% to 20% increase allowable gross vehicle weight did not have a significant impact on the fatigue life of bridges" (quoting Helgason et al, 1976)</li> <li>• Fatigue damage (unitless share of all damage) attributable to each truck model</li> <li>• Annual South Carolina bridge damage costs</li> </ul>	<ul style="list-style-type: none"> <li>• 12% higher main axle weights result in an incremental 25 to 27% negative effect on fatigue life.</li> <li>• The addition of the third axle to the rear axle grouping results in a negative effect on fatigue life on the order of 29 to 54%.</li> <li>• A negative incremental effect on fatigue life will be up to 66% due to the closely spaced axles.</li> </ul>

Study	2003 Minnesota DOT Study	2013 SCDOT Study	2014 CTSW Study
	of up to 42% and a 10% increase would lead to a 25% reduction in fatigue life.		

**2.2.6 Summary**

Load induced fatigue behavior on steel bridges has been well studied under constant amplitude cycle loading and AASHTO has established design specifications and evaluation specifications for fatigue behaviors based on those studies. Essentially, fatigue life is inversely proportional to the cube of the effective stress range per AASHTO. With the increase of size and passing cycles of overweight trucks, fatigue behavior under low magnitude and variable amplitude cycle loading has attracted more attention from engineers and researchers recently and would be a direction of future research.

**2.2.7 List of References**

<b>Methods and Impact of the Bridge Fatigue Limit State</b>			
Reference No.	Document No.	Document Title and Link	Relevance to Study
2.2.7-1	ASCE JBE 2005 10:1 -12	Truck Loading and Fatigue Damage Analysis for Girder Bridges Based on Weigh-in-Motion Data. Wang, Liu, Huang, Shahawy, ASCE Journal of Bridge Engineering, 2005 <a href="http://ascelibrary.org/doi/pdf/10.1061/%28ASCE%291084-0702%282005%2910%3A1%2812%29">http://ascelibrary.org/doi/pdf/10.1061/%28ASCE%291084-0702%282005%2910%3A1%2812%29</a>	Fatigue
	Based on data collected by weigh-in-motion (WIM) measurements, truck traffic is synthesized by type and loading condition. Three-dimensional nonlinear models for the trucks with significant counts are developed from the measured data. Six simply supported multi-girder steel bridges with spans ranging from 10.67 m (35 ft) to 42.67 m (140 ft) are analyzed using the proposed method. Road surface roughness is generated as transversely correlated random processes using the autoregressive and moving average model. The dynamic impact factor is taken as the average of 20 simulations of good road roughness. Live-load spectra are obtained by combining static responses with the calculated impact factors. A case study of the normal traffic from a specific site on interstate highway I-75 is illustrated. Static loading of the heaviest in each truck type is compared with that of the AASHTO standard design truck HS20-44. Several important trucks causing fatigue damage are found.		
2.2.7-2	NSBA	A Fatigue Primer for Structural Engineers; Fisher, John W., Lehigh University; Kulak, Geoffrey L, University of Alberta; Smith, Ian F. C., Swiss Federal Institute of Technology; National Steel Bridge Alliance; 1998 <a href="http://www.aisc.org/store/p-1638-a-fatigue-primer-for-structural-engineers-pdf-download.aspx">http://www.aisc.org/store/p-1638-a-fatigue-primer-for-structural-engineers-pdf-download.aspx</a>	Fatigue, Fracture Critical, Design
	This publication from the NSBA provides guidelines for the understanding of fundamentals in the fatigue of metals, and the recognition of fracture critical details. The purpose of this publication is to provide a background of (information) to understand the design rules for fatigue strength that		

<b>Methods and Impact of the Bridge Fatigue Limit State</b>			
Reference No.	Document No.	Document Title and Link	Relevance to Study
		are currently part of the design codes for fabricated steel structures	
2.2.7-3	AISC -1977	Bridge Fatigue Guide Design and Detail; 1977; Fisher, John W., Lehigh University, 1977 <a href="http://www.aisc.org/search.aspx?id=3852&amp;keyword=Bridge%20Fatigue%20Guide%20Design%20&amp;Detail">http://www.aisc.org/search.aspx?id=3852&amp;keyword=Bridge Fatigue Guide Design &amp; Detail</a>	Fatigue Guide
		This document is a guide and introduction to the fatigue problems in bridges, provides design details to optimize fatigue strength, concepts, considerations and examples for bridge engineers and designers.	
2.2.7-4	NYSDOT TA 12-002	Fatigue Evaluation 100% Hand-on Exemption; NYSDOT Technical Advisory for Bridge Engineer / Inspectors, 2012 <a href="https://www.dot.ny.gov/divisions/engineering/structures/repository/manuals/inspection/bim_ta12-002.pdf">https://www.dot.ny.gov/divisions/engineering/structures/pository/manuals/inspection/bim_ta12-002.pdf</a>	Fatigue, Inspection
		This document provides the means and methods for exempting the inspection of fatigue sensitive and fracture critical details by NYSDOT using various AASHTO publications. It is an indication of current practice by DOT's around the country.	
2.2.7-5	NCHRP Project 12-15	Members Under Variable Amplitude, Long Life Fatigue Loading, Final Report; 1983 Fisher, J. W., D. R. Mertz, and A. Zhong. Steel Bridge Lehigh University, Bethlehem, Pa. <a href="http://preserve.lehigh.edu/engr-civil-environmental-fritz-lab-reports/2246">http://preserve.lehigh.edu/engr-civil-environmental-fritz-lab-reports/2246</a> .	Fatigue
2.2.7-6	FHWA/IN/JT RP-2005/16-1	Fatigue of Older Bridges in Northern Indiana due to Overweight and Oversized Loads - Volume 1& 2: Bridge and Weigh-In-Motion Measurements; 2006; James A. Reisert and Mark D. Bowman; Purdue University; Indiana DOT; Joint Transportation Research Program <a href="http://docs.lib.purdue.edu/cgi/viewcontent.cgi?article=1726&amp;context=jtrp">http://docs.lib.purdue.edu/cgi/viewcontent.cgi?article=1726&amp;context=jtrp</a>	Fatigue, Overweight Truck Study, WIM
		<p><b>Abstract:</b> This report is the first of a two-volume final report presenting the findings of the research work that was undertaken to evaluate the fatigue behavior of steel highway bridges on the extra heavy weight truck corridor in Northwest Indiana. The purpose of the study was to evaluate the type and magnitude of the loads that travel along the corridor and then assess the effect of those loads on the fatigue strength of the steel bridge structures. This volume presents the results of the experimental field study conducted to evaluate the load and load effects on one steel bridge structure on the corridor. A weigh-in-motion (WIM) system was installed near the bridge structure to evaluate the loads that would cross over the bridge being monitored. Strain values were monitored on two spans of the ten-span continuous bridge.</p> <p>Comparisons were then made between strain measurements in particular girders and strain values predicted using the measured truck axle weights. The WIM data indicated that 15% of the Class 9 trucks and 26% of the Class 13 trucks travel heavier than their respective legal limits. Extreme weights of more than 200,000 lbs were observed. In spite of the heavy truck loads being carried, it was found that less than 1 percent of the trucks induce a strain range that exceeds the variable amplitude fatigue limit of the fatigue critical details in the structure being monitored. Lastly, it was found that three dimensional analytical models provide the best agreement between predicted</p>	



<b>Methods and Impact of the Bridge Fatigue Limit State</b>			
Reference No.	Document No.	Document Title and Link	Relevance to Study
		and measured strain values in the bridge. The titles of the two volumes (Report Number in parentheses) are listed below: Volume 1: Bridge and Weigh-In-Motion Measurements (FHWA/IN/JTRP-2005/16-1) Volume 2: Analysis Methods and Fatigue Evaluation (FHWA/IN/JTRP-2005/16-2)	
2.2.7-7	TRB Report 299	Fatigue Evaluation Procedures for Steel Bridges; F. Moses, C.G. Schilling, K.S. Raju, Case Western Reserve University <a href="http://www.trb.org/Publications/Pages/262.aspx">http://www.trb.org/Publications/Pages/262.aspx</a>	Fatigue
		The primary purpose of this study was to develop improved procedures for the fatigue evaluation of existing steel bridges. A secondary objective was to develop improved procedures for the fatigue design of new steel bridges. The evaluation procedures are recommended for inclusion as Section 6 in the AASHTO Manual for Maintenance Inspection of Bridges and the design procedures are recommended for inclusion as Articles 10.3.1 and 10.3.2 in the AASHTO Standard Specifications for Highway Bridges.	
2.2.7-8	FHWA-IF-12-052	US Department of Transportation Federal Highway Administration, Steel Bridge Design Handbook, Design for Fatigue <a href="http://www.fhwa.dot.gov/bridge/steel/pubs/if12052/volume12.pdf">http://www.fhwa.dot.gov/bridge/steel/pubs/if12052/volume12.pdf</a>	Fatigue
		Fatigue in metals is the process of initiation and growth of cracks under the action of repetitive tensile loads. If crack growth is allowed to go on long enough, failure of the member can result when the uncracked cross-section is sufficiently reduced such that the member can no longer carry the internal forces or the crack extends in an unstable mode. The fatigue process can take place at stress levels that are substantially less than those associated with failure under static loading conditions. The usual condition that produces fatigue cracking is the application of a large number of load cycles. Consequently, the types of civil engineering applications that are susceptible to fatigue cracking include structures such as bridges. This document provides the practicing engineer with the background required to understand and use the design rules for fatigue resistance that are currently a standard part of design codes for fabricated steel structures.	
2.2.7-9	NSCC2009	Fatigue Prone Details in Steel Bridges; El Emrani, M; Kliger, R.; Chalmers University of Technology, Göteborg, Sweden <a href="http://www.nordicsteel2009.se/pdf/147.pdf">http://www.nordicsteel2009.se/pdf/147.pdf</a>	Fatigue
		<b>Abstract:</b> This paper reviews the results of a large investigation of more than 100 fatigue damage cases, reported for steel and composite bridges. The damage cases were categorized according to the type of detail in which they were encountered and the mechanisms behind fatigue damage in each category were identified and studied. It was found that more than 90% of all reported damage cases are of the deformation-induced type and are generated by some kind of unintentional or otherwise overlooked interaction between different load-carrying members or systems in the bridge. Poor detailing, with unstiffened gaps and abrupt changes in stiffness at the connections between different members, also contributed to fatigue cracking in most details.	
2.2.7-10	ASCE-SE-1995	Fatigue-Based Methodology for Managing Impact of Heavy-Permit Trucks on Steel Highway Bridges, Dicleli, Bruneau, ASCE Journal of Structural Engineering, 1995 <a href="http://www.tucsa.org/images/yayinlar/makaleler/ASCE-SE-">http://www.tucsa.org/images/yayinlar/makaleler/ASCE-SE-</a>	Fatigue

<b>Methods and Impact of the Bridge Fatigue Limit State</b>			
Reference No.	Document No.	Document Title and Link	Relevance to Study
		<a href="http://www.dot.state.fl.us/research-center/Completed_Proj/Summary_STR/FDOT_BC379_rpt.pdf">1995-high-cycle-fatigue-in-steel-bridges.pdf</a>	
		<p>Currently, in many areas of North America, special permits are issued to extra heavy vehicles without a detailed evaluation of individual components, considering only the ultimate capacity of the bridge inventory as a whole. Based on this, a large number of special permits have been issued to extra heavy vehicles. In this perspective, the ultimate and cumulative effect of such overloads on steel bridge components was studied. It was found that steel bridge members have adequate ultimate capacity to accommodate such overloads; however, they may suffer fatigue damage due to the cumulative effect of these overloads. Accordingly, a fatigue-based methodology was developed to assess the reduction in service life of bridges due to heavy-permit trucks. It is found that a reasonably large number of special permits can be issued at small reductions in fatigue life, but because stress ranges in excess of the constant-amplitude fatigue limit significantly alter the shape of the S-N curve, it is essential to appreciate that the concept of infinite fatigue life cannot be relied upon anymore.</p>	
2.2.7-11	FL/DOT/RM C/6672-379	Influence of Heavy Trucks on Highway Bridges, Ton-Lo Wang, Chunhua Liu, Florida International University, 2000 <a href="http://www.dot.state.fl.us/research-center/Completed_Proj/Summary_STR/FDOT_BC379_rpt.pdf">http://www.dot.state.fl.us/research-center/Completed_Proj/Summary_STR/FDOT_BC379_rpt.pdf</a>	Fatigue
		<p>The objective of this study includes the following aspects: (1) synthesize truck traffic data collected through WIM measurements; (2) establish live-load spectra; (3) perform fatigue damage analysis for typical bridges; (4) carry out static and dynamic analyses. Three-dimensional nonlinear mathematical models of typical trucks with significant counts are developed based on the measured axle weights and configurations. Road surface roughness is simulated as transversely correlated random processes. The multi-girder bridges are treated as a grillage beam system.</p>	
2.2.7-12	FHWA/LA.0 6/418	Monitoring System to Determine the Impact of Sugarcane Truckloads on Non-Interstate Bridges; Saber Aziz, Freddy Roberts, Louisiana Tech University, 2008 <a href="http://www.ltrc.lsu.edu/pdf/2009/fr_418.pdf">http://www.ltrc.lsu.edu/pdf/2009/fr_418.pdf</a>	Fatigue
		<p>The study included in this report assessed the strength, serviceability, and economic impact caused by overweight trucks hauling sugar cane on Louisiana bridges. Researchers identified the highway routes and bridges being used to haul this commodity and statistically chose samples to use in the analysis. Approximately 84 bridges were involved in this study. Four different scenarios of load configuration were examined:</p> <ol style="list-style-type: none"> <li>1. GVW = 100,000 lb., with a maximum tandem load of 48,000 lb.,</li> <li>2. GVW = 100,000 lb., with a maximum triple axle load of 60,000 lb.,</li> <li>3. Uniformly distributed tandem and triple axle loads, and</li> <li>4. GVW = 120,000 lb., with maximum tandem of 48,000 lb., and maximum triple axle of 60,000 lb.</li> </ol> <p>It is to be noted that a GVW of 120,000 lb. for sugarcane haulers was the highest level currently considered in this investigation. The methodology used to evaluate the fatigue cost of bridges was based on the following procedures: 1) determine the shear, moment, and deflection induced on each bridge type and span, and 2) develop a fatigue cost for each truck crossing with a) a maximum GVW of 120,000 lb., and b) a GVW of 100,000 lb. with a uniformly distributed load. Through the use of a field calibrated finite element model, Structure 03234240405451 was analyzed and load rated for loading vehicles HS-20, 3S2 and 3S3 (sugar cane loading cases 1 thru 4). The structure had adequate strength to resist both bending and shear forces for all six loading</p>	

<b>Methods and Impact of the Bridge Fatigue Limit State</b>			
Reference No.	Document No.	Document Title and Link	Relevance to Study
		<p>vehicles. It should be noted that all of the rating factors were acceptable for all 17 spans as long as the construction and the structural condition of each span were the same. Results indicate that among the four cases of loading configurations, Case 4, which was a GVW=120,000 lb. with maximum tandem and triple axle loads, generated the worst strength and serviceability conditions in bridges. Therefore, Case 4 is the loading configuration that controls the strength analysis and evaluation of fatigue cost for bridge girders. Based on the controlling load configuration, Case 4 with a GVW = 120, 000 lb., the estimated fatigue cost is \$11.75 per trip per bridge. In Case 3, which was a GVW = 100,000 lb. uniformly distributed load; the estimated cost is \$0.90 per trip per bridge. The results from the bridge deck analyses indicate that the bridge deck is under a stable stress state, whether the stresses are in the tension zone or the compression zone. Moreover, the decks of bridges with spans longer than 30 ft. may experience cracks in the longitudinal direction under 3S3 trucks. Such cracks will require additional inspections along with early and frequent maintenance. Based on the results of the studies presented in this report, it is recommended that truck configuration 3S3 be used to haul sugar cane with a GVW of 100,000 lb. uniformly distributed. This will result in the lowest fatigue cost on the network. It is recommended that truck configuration 3S3 not be used to haul sugar cane with GVW of 120,000 lb. This will result in high fatigue cost on the network and could cause failure in bridge girders and bridge decks.</p>	
2.2.7-13	2010 Vol. 4:10-35 ISSN 1934-7359	Economic Impact of Higher Timber Truck Loads on Louisiana Bridges; Saber Aziz, Louisiana Tech University, Journal of Civil Engineering and Architecture, 2010 <a href="http://www.davidpublishing.com/davidpublishing/Upfile/5/21/2013/2013052171895729.pdf">http://www.davidpublishing.com/davidpublishing/Upfile/5/21/2013/2013052171895729.pdf</a>	Fatigue
		<p>Due to the limited amount of funds available for bridge inspection, maintenance and rehabilitation, the evaluation of load capacity for existing bridges is crucial to the Louisiana Department of Transportation to development in general. This paper includes the development of a methodology to assess the economic impact of overweight vehicles with permits, hauling Louisiana harvest products on state bridges. The proposed higher truck loads are applied on the existing bridges and their effects are determined using deterministic load capacity evaluations as well as reliability assessments. The target reliability level is derived from bridge structures designed to satisfy AASHTO Standard Design Specifications and also satisfy safe and adequate performance levels. The amount of harvest produced is used to select a representative sample of bridges to provide specific examples of expected changes in load ratings and safety levels. The bridges include simple and continuous span behavior. Strength and serviceability criteria are investigated under current legal loads and the expected changes, due to the proposed new weights, are determined. The results are used to assess the cost of crossing a bridge and the permit fees for the proposed truck weight regulation.</p>	
2.2.7-14	FHWA/LA.1 3/509	Load Distribution and Fatigue Cost Estimates of Heavy Truck Loads on Louisiana State Bridges, Aziz Saber, 201, LDOT, Louisiana Tech University <a href="http://www.ltrc.lsu.edu/pdf/2013/FR_509.pdf">http://www.ltrc.lsu.edu/pdf/2013/FR_509.pdf</a>	Fatigue
		<p>The bridge in this study was evaluated and a monitoring system was installed to investigate the effects of heavy loads and the cost of fatigue for bridges on state highways in Louisiana. Also, this study is used to respond to Louisiana Senate Concurrent Resolution 35 (SCR-35). The superstructure of the bridge in this study was evaluated for safety and reliability under four</p>	

<b>Methods and Impact of the Bridge Fatigue Limit State</b>			
Reference No.	Document No.	Document Title and Link	Relevance to Study
		<p>different kinds of truck configuration and loads hauling sugarcane. The bridge model was verified by performing live load tests using 3S3 trucks with a gross vehicular weight (GVW) of 100,000 lb. on the structure. The bridge finite element model was analyzed under the different kinds of loading and the effects were listed and compared. The results of the analyses show that the pattern of response of the bridge under the different cases follows the same trend. Among the four different cases of loading configurations, case 4, which was GVW =148,000 lb. and a vehicle length of 92 ft., produced the largest tensile and compressive stresses in the members. The results from the bridge deck analyses confirm that the bridge deck is under a stable stress state, whether the stresses are in the tension zone or the compression zone. The heavy load as indicated in SCR-35 will cause damage to bridges.</p> <p>The data from the monitoring system indicates that the average number of heavy loads during October, November, and December is 3.5 times higher than the rest of the year. The bridges are exposed to high cycles of repetition of heavy loads that will reduce the life span of the bridges by about 50%. The bridges that are built to last 75 years will be replaced after about 40 years in service. This seasonal impact is due to the sugarcane harvest and confirms the cost of fatigue, \$0.9 per truck per trip per bridge, as determined in the previous study.</p> <p>Based on the results of the studies presented in this report, increasing the gross vehicle weight of sugarcane trucks is not recommended. The heavy loads indicated in SCR-35 will cause premature fatigue damage to the main structural members and could cause their eventual structural failure. In addition, the majority of the Louisiana bridges currently in service were designed to accommodate lower loads than the bridge tested on this project. Therefore, based on the test results, one should expect that the proposed trucks will significantly shorten the remaining life span of Louisiana bridges. All these bridges should be rehabilitated prior to implementing SCR 35. The data from the monitoring system will provide a good source of information to review the current serviceability criteria used by the Louisiana Department of Transportation and Development (LADOTD) for the design of prestressed concrete bridge girders.</p> <p><i>It appears that the ultra-heavy weight trucks will subject the bridges to excessive stresses in the girders and may be approaching the ultimate strength of the superstructures. Indeed under such circumstances the bridges will suffer. However, the fatigue design is a separate issue. Bridges are not necessarily replaced when they reach the end of the fatigue life. Rather fatigue details are retrofitted or removed allowing the bridge to continue to service traffic in its original form.</i></p>	
2.2.7-15	ASCE JBE 2003 8:5-259	Finite-Element Analysis of Steel Bridge Distortion-Induced Fatigue, Roddis, Zhao, 2003 ASCE Journal of Bridge Engineering <a href="http://ascelibrary.org/doi/pdf/10.1061/%28ASCE%291084-0702%282003%298%3A5%28259%29">http://ascelibrary.org/doi/pdf/10.1061/%28ASCE%291084-0702%282003%298%3A5%28259%29</a>	Fatigue
		<p>Welded plate girder bridges built before the mid-1980s are often susceptible to fatigue cracking driven by out-of-plane distortion. However, methods for prediction of secondary stresses are not specifically addressed by bridge design specifications. This paper presents a finite-element study of a two-girder bridge that developed web gap cracks at floor truss-girder connections. The modeling procedures performed in this research provide useful strategies that can be applied to determine the magnitude of distortion-induced stresses, to describe the behavior of crack development, and to assess the effectiveness of repair alternatives. The results indicate severe stress concentration at the crack initiation sites. The current repair method used at the positive moment region connections is found to be acceptable, but that used at the negative moment region connections is not satisfactory, and additional floor truss member removal is required. Stress</p>	

<b>Methods and Impact of the Bridge Fatigue Limit State</b>			
Reference No.	Document No.	Document Title and Link	Relevance to Study
		ranges can be lowered below half of the constant amplitude fatigue threshold, and fatigue cracking is not expected to recur if the proposed retrofit approach is carried out.	
2.2.7-16	TRB 2003 Annual Meeting	Finite Element Study of Distortion-Induced Fatigue in Welded Steel Bridges <a href="http://www.ltrc.lsu.edu/TRB_82/TRB2003-001245.pdf">http://www.ltrc.lsu.edu/TRB_82/TRB2003-001245.pdf</a>	Fatigue
		<p>Out-of-plane distortion-induced fatigue cracking is caused by relative rotation and displacement between longitudinal girders and transverse members framing into these girders. Procedures for determination of secondary stresses are not specified in the design or rating process. This paper presents appropriate finite element method procedures to analyze distortion-induced fatigue behavior. A multi-girder bridge developed web gap cracks near the girder bottom flange in a positive moment region. The affected diaphragm-girder connections were repaired by installing additional reinforcing splice plates to the web and attaching connection stiffeners to the flanges. Since no structural modifications were made to similar details in the bridge that had not developed fatigue cracks, concerns remain that these details may also be subjected to high magnitude fatigue stresses that may lead to future cracking. By using finite element sub-modeling techniques, potential crack initiation sites in the bridge were identified and the corresponding distortion-induced stresses were determined. The most stressed detail reached yielding with an out-of-plane displacement of only a few thousandths of an inch. Based on the analytical results, a linear stress displacement correlation was established for prediction of the secondary stresses. Repair analysis indicated that web gap stresses can be significantly reduced if a rigid stiffener-to-flange attachment is used. Thus, a bolted repair is recommended for the positive moment region connections and a welded repair is recommended for the transition and negative moment region connections.</p>	
2.2.7-17	MN/RC-2003-16	Effects of Increasing Truck Weight on Steel and Pre-stressed Bridges <a href="http://www.dot.state.mn.us/ofrw/PDF/200316.pdf">http://www.dot.state.mn.us/ofrw/PDF/200316.pdf</a>	
		<p>Any increase in legal truck weight would shorten the time for repair or replacement of many bridges. Five steel girder bridges and three pre-stressed concrete I-girder bridges were instrumented, load tested, and modeled. The results were used to assess the effects of a 10 or 20% increase in truck weight on bridges on a few key routes through the state. Essentially it was found that all pre-stressed girders, modern steel girders, and most bridge decks could tolerate a 20% increase in truck weight with no reduction in life. Unfortunately, most Minnesota steel girder bridges were designed before fatigue-design specifications were improved in the 1970's and 1980's. Typically, an increase in truck weight of 20% would lead to a reduction in the remaining life in these older steel bridges of up to 42% (a 10% increase would lead to a 25% reduction in fatigue life). <b>Bridge decks are affected by axle weights rather than overall truck weights.</b> Transverse cracks in bridge decks are primarily caused by shrinkage soon after construction and are not affected by increasing axle weight. However, decks with thickness less than 9 inches or with girder spacing greater than 10 ft may be susceptible to longitudinal flexural cracking which could decrease life.</p> <p><i>This is an important finding for the current study in general and as it relates to crack propagation in bridge decks.</i></p>	
2.2.7-18	FHWA/TX-07/0-1895-1	Evaluation of Serviceability Requirements for Load Rating Pre-stressed Concrete Bridges; Wood, S. L., M. J. Hagenberger, B. E. Heller, and P. J. Wagener. 2007. Texas Department of	Load Rating, Pre-Stressed Concrete;

Methods and Impact of the Bridge Fatigue Limit State			
Reference No.	Document No.	Document Title and Link	Relevance to Study
		Transportation, Jan. 2007 <a href="http://fsel.engr.utexas.edu/publications/detail.cfm?pubid=626092718">http://fsel.engr.utexas.edu/publications/detail.cfm?pubid=626092718</a>	Fatigue,
	<p>Within Texas, the procedures in the AASHTO Manual for Condition Evaluation of Bridges (MCEB) are used to determine the load rating of existing structures. A large number of pre-stressed concrete bridges that were constructed in the 1950s and 1960s have load ratings that fall below the minimum design vehicle specified in the MCEB. The load ratings for this group of bridges are typically controlled by the serviceability limit state criterion related to the tensile stress in the concrete. A low load rating implies that these bridges have experienced damage under service loads. However, observations made by TXDOT personnel during routine inspections indicate that the condition of these bridges is very good, and that there are generally no signs of deterioration.</p> <p>Based on the results of the diagnostic load tests and laboratory fatigue tests, it was concluded that the tensile stress criterion in the MCEB should not be used to evaluate existing pre-stressed concrete bridges. The calculated tensile stress in the concrete is not a reliable indicator of the stresses induced in the strand due to live load. Conservative guidelines for considering the fatigue limit state explicitly in the load rating process were developed.</p>		
2.2.7-19	MN/RC – 2005-38	Analysis of Girder Differential Deflection and Web Gap Stress for Rapid Assessment of Distortional Fatigue in Multi-Girder Steel Bridges; MN/DOT <a href="http://www.lrrb.org/media/reports/200538.pdf">http://www.lrrb.org/media/reports/200538.pdf</a>	Steel & RC Fatigue
	<p><b>Abstract:</b> Distortion-induced fatigue cracking in unstiffened web gaps is common in steel bridges. Previous research by the Minnesota Department of Transportation (Mn/DOT) developed methods to predict the peak web gap stress and maximum differential deflection based upon field data and finite element analyses from two skew supported steel bridges with staggered bent-plate and cross-brace diaphragms, respectively. This project aimed to test the applicability of the proposed methods to a varied spectrum of bridges in the MN/DOT inventory. An entire bridge model (macro-model) and a model encompassing a portion of the bridge surrounding the diaphragm (micro-model) were calibrated for two instrumented bridges. Dual-level analyses using the macro- and micro-models were performed to account for the uncertainties of boundary conditions. Parameter studies were conducted on the prototypical variations of the bridge models to define the sensitivity of diaphragm stress responses to typical diaphragm and bridge details. Based on these studies, the coefficient in the web gap stress formula was calibrated and a linear prediction of the coefficient was proposed for bridges with different span lengths. Additionally, the prediction of differential deflection was calibrated to include the influence of cross bracing diaphragms, truck loading configurations and additional sidewalk railings. A simple approximation was also proposed for the influence of web gap lateral deflection on web gap stress.</p>		
2.2.7-20	ACI 215R-74	ACI 215R-74 Consideration for Design of Concrete Structures Subjected to Fatigue Loading ACI Code	Concrete Fatigue
	<p>In recent years, considerable interest has developed in the fatigue strength of concrete members. There are several reasons for this interest. First, the widespread adoption of ultimate strength design procedures and the use of higher strength materials require that structural concrete members perform satisfactorily under high stress levels. Hence there is concern about the effects</p>		

<b>Methods and Impact of the Bridge Fatigue Limit State</b>			
Reference No.	Document No.	Document Title and Link	Relevance to Study
		<p>of repeated loads on, for example, crane beams and bridge slabs.</p> <p>Second, new or different uses are being made of concrete members or systems, such as pre-stressed concrete railroad ties and continuously reinforced concrete pavements. These uses of concrete demand a high performance product with an assured fatigue strength.</p> <p>Third, there is new recognition of the effects of repeated loading on a member, even if repeated loading does not cause a fatigue failure. Repeated loading may lead to inclined cracking in pre-stressed beams at lower than expected loads, or repeated loading may cause cracking in component materials of a member that alters the static load carrying characteristics.</p> <p>This report is intended to provide information that will serve as a guide for design for concrete structures subjected to fatigue loading. However, this report does not contain the type of detailed design procedures sometimes found in guides.</p>	
2.2.7-21	ENGINEERING JOURNAL Volume 17 Issue 1	<p>Finite Element Analysis of Distortion-Induced Web Gap Stresses in Multi-I Girder Steel Bridges, Akhrawat Lenwari1, (Chulalongkorn University), Huating Chen (Beijing University of Technology), 2012</p> <p><a href="http://engj.org/index.php/ej/article/view/322/271">http://engj.org/index.php/ej/article/view/322/271</a></p>	Distortion Fatigue
		<p><b>Abstract:</b> Unstiffened girder web gaps at the ends of transverse stiffeners that also serve as diaphragm connection plates are subjected to high local stresses during cyclic out-of-plane distortion. The out-of-plane distortion is mainly caused by the differential deflection between adjacent girders. The purpose of the paper is to investigate the effects of bridge parameters including span length, girder spacing, slab thickness, and girder stiffness on the differential deflection and distortion-induced web gap stresses. Dual-level finite element analyses that consist of both global model and sub-model were performed. The global model was used to investigate the critical truck position and maximum differential deflection between adjacent girders, while the sub-model was used for the critical web gap vertical stress. A base case bridge was a simply supported composite superstructure with three steel I-girders that support two traffic lanes, which is typical for steel bridges over intersections in Bangkok, Thailand. A parametric study was conducted by varying one bridge parameter at a time. The analysis results show that the maximum differential deflections and web gap stresses caused by one-truck loading are higher than those caused by two-truck loading (one truck on each lane). Under one-truck loading, the maximum web gap stress occurs at the interior girder. In addition, both the differential deflections and web gap stresses are primarily dependent on the bridge span length.</p>	
2.2.7-22	NCHRP SYN 354	<p>NCHRP Synthesis 354: Inspection and Management of Bridges with Fracture Critical Details; Conner, Robert, Purdue University; Dexter, Robert, University of Minnesota, 2005</p> <p><a href="http://onlinepubs.trb.org/onlinepubs/nchrp/nchrp_syn_354.pdf">http://onlinepubs.trb.org/onlinepubs/nchrp/nchrp_syn_354.pdf</a></p>	Fatigue
		<p>This report is focused on inspection and maintenance of bridges with fracture-critical members (FCMs). The AASHTO LRFD Bridge Design Specifications (LRFD Specifications) defines an FCM as a “component in tension whose failure is expected to result in the collapse of the bridge or the inability of the bridge to perform its function.” Note that the FCM can refer to a component such as a flange of a girder and does not necessarily include the whole “member.” Approximately 11% of the steel bridges in the United States have FCMs. Most of these (83%) are two-girder bridges and two-line trusses, and 43% of the FCMs are built-up riveted members.</p> <p>The objectives of this synthesis project were to:</p> <ul style="list-style-type: none"> <li>• Survey the extent of and identify gaps in the literature;</li> </ul>	

<b>Methods and Impact of the Bridge Fatigue Limit State</b>			
Reference No.	Document No.	Document Title and Link	Relevance to Study
		<ul style="list-style-type: none"> <li>• Determine best practices and problems with how bridge owners define, identify, document, inspect, and manage bridges with fracture-critical details; and</li> <li>• Identify research needs</li> </ul>	
2.2.7-23	TRB 1696	Highway Network Bridge Fatigue Damage Potential of Special Truck Configurations; International Bridge Engineering Conference; National Research Council; 2000, Jeffrey A. Laman, John R. Ashbaugh; <a href="http://academic.research.microsoft.com/Publication/27566789/highway-network-bridge-fatigue-damage-potential-of-special-truck-configurations">http://academic.research.microsoft.com/Publication/27566789/highway-network-bridge-fatigue-damage-potential-of-special-truck-configurations</a>	Fatigue; Truck Configuration
<p>A study of the fatigue damage potential of special truck configurations was conducted to facilitate informed decisions by state transportation agencies in considering various truck size and weight and permit policies as well as to provide relative damage information that will be useful in ongoing network damage evaluations. The primary objective was to evaluate 78 existing common and FHWA-proposed truck configurations for relative fatigue damage potential. To accomplish this objective, an analytical fatigue evaluation tool was developed to determine the relative fatigue damage induced in highway network bridges by simulation of a highway fleet mix database crossing actual bridges modeled analytically. Additional objectives were to evaluate the influence of impact values and endurance limits used for a fatigue analysis. The semi-continuum analysis method, the Palmgren-Miner hypothesis, and the rain flow cycle counting algorithm are incorporated. A 39-bridge database statistically selected as representative of bridges in the United States allowed a network level fatigue analysis of several hundred fatigue-prone details. Seventy-eight special truck configurations were studied, 25 of which were developed by FHWA as part of the comprehensive truck size and weight study. The remaining 53 vehicles were taken from the Turner proposal, Michigan, Pennsylvania, Canada, military, AASHTO, and other sources. It was found that fatigue damage potential is primarily a function of axle weight, spacing, and vehicle length instead of gross vehicle weight.</p> <p><i>The importance and relevance of this study was that it suggested a method to rate fatigue damage relative to truck GVW and configuration as it analyzed numerous truck configuration (including similar trucks proposed on the Turner Proposal (TRB Special Reports 225 &amp; 227) as well as this study) on real representative bridge types.</i></p>			
2.2.7-24	ASCE JBE 2003 8:5-(312)	Predicting Truck Load Spectra Under Weight Limit Changes and Its Application to Steel Bridge Fatigue Assessment. Cohen, H., G. Fu, W. Dekelbab, and F. Moses. 2003. Journal of Bridge Engineering, Vol. 8, No. 5, pp. 312–322. Available through American Society of Civil Engineering Journal Library: <a href="http://ascelibrary.org/doi/pdf/10.1061/(ASCE)1084-0702(2003)8%3A5(312)">http://ascelibrary.org/doi/pdf/10.1061/(ASCE)1084-0702(2003)8%3A5(312)</a>	Fatigue
<p><i>This document was included in the list of references in NCHRP Report 495. However the NAS Peer Review Committee asked for specific reference herein. This article specifies a method to select the most appropriate fatigue truck given a certain truck histogram under a specific modal shift. The method seeks out the average truck and standard deviation used in an equation to derive an amplification factor to apply to the AASHTO designated fatigue truck.</i></p>			
2.2.7-25	NCHRP Rpt	NCHRP Report 721: Fatigue Evaluation of Steel Bridges,	Fatigue,



<b>Methods and Impact of the Bridge Fatigue Limit State</b>			
Reference No.	Document No.	Document Title and Link	Relevance to Study
	721	Bowman, M. D., G. Fu, Y. E. Zhou, R. J. Connor, and A. A. Godbole, 2012. Purdue University, Transportation Research Board of the National Academies, Washington, D.C. <a href="http://onlinepubs.trb.org/onlinepubs/nchrp/nchrp_rpt_721.pdf">http://onlinepubs.trb.org/onlinepubs/nchrp/nchrp_rpt_721.pdf</a>	Fatigue Truck
<p>There were three objectives on NCHRP Project 12-81 Validation of the AASHTO Fatigue Truck since the fatigue provisions of the AASHTO Manual of Bridge Evaluation appeared to be overly conservative in the view of many practicing engineers. The research program aims toward the revision of Section 7 of the MBE to advance the state of the art and the practice. Items specifically identified as in need of improvement include:</p> <ol style="list-style-type: none"> <li>1. Improved methods utilizing a reliability-based approach to assess the fatigue behavior and aid bridge owners in making appropriate operational decisions.</li> <li>2. Guidance on the evaluation of retrofit and repair details used to assess fatigue cracks.</li> <li>3. Guidance for the evaluation of distortion-induced fatigue cracks.</li> </ol>			
2.2.7-26	FHWA/TX-83/8+247-4	Estimation of the Fatigue Life of a Test Bridge from Traffic Data. Research Hoadley, P., K. Frank, and J. Yura. 1983. Center for Transportation Research, University of Texas at Austin. <a href="http://library.ctr.utexas.edu/digitized/TexasArchive/phase1/247-4-CTR.pdf">http://library.ctr.utexas.edu/digitized/TexasArchive/phase1/247-4-CTR.pdf</a>	Fatigue
<p>Fatigue studies were conducted on a twin-girder, multi-lane highway bridge. Two types of stress histories were measured at several locations on the bridge. One type of stress history was measured during the passage of a test truck of known weight. Stress histories were measured for velocities of the test truck of 5, 35 and 50 m.p.h. The second type of stress history was measured under normal traffic conditions.</p> <p>An effective stress range, SRE' and number of cycles were computed from each measured stress history using the Rainflow Cycle Counting method in conjunction with Miner's linear damage rule. Other cycle counting methods are considered and compared with the Rainflow Cycle Counting method. The values of SRE and number of cycles are used to compute fatigue-life estimates for the bridge. The fatigue life estimates were computed as a function of the amount of fatigue damage occurring per hour and per day, and future increases in traffic and axle loads were considered.</p> <p>The longitudinal-transverse stiffener intersection, LTSI, detail was found to control the fatigue life of the bridge. The estimated fatigue life for this detail was 50 to 85 years. A modified LTSI detail increased the fatigue life by a factor of three.</p>			
2.2.7-27	Paper 98-0417	Fatigue Impacts on Bridge Cost Allocation; Laman, J.A.; Ashbaugh, J.R., 1997 <a href="http://trid.trb.org/view.aspx?id=540784">http://trid.trb.org/view.aspx?id=540784</a>	HCAS, Fatigue
<p>The objectives of this project was to develop an analytical tool to evaluate relative user responsibility for fatigue damage on highway bridges. The tool was a FORTRAN program designed to read standard format FHWA files on vehicle data including Vehicle Miles Traveled (VMT) and the output is a relative fatigue damage matrix for each weight group. The relative damage factors are then used in a cost allocation study to assign the cost of fatigue damage. 39 representative bridges throughout the United States were selected.</p> <p><i>This was an interesting study in two ways. First it was a cost allocation method attempting to allocate cost not by a load based allocator but rather by a generic VMT allocator. This was a</i></p>			

<b>Methods and Impact of the Bridge Fatigue Limit State</b>			
Reference No.	Document No.	Document Title and Link	Relevance to Study
		<i>deviation from the Incremental Method. Secondly it is the only attempt at conducting a study on bridges on a national scale. There are potential weaknesses in terms of the allocators used and the number of bridges selected, however this may be due to computational power and technology available during the mid to late 90's. The results of the analysis was used in 1997 HCAS</i>	
2.2.7-28	LTRC_228 TRB 09_228	Effects of Heavy Truck Operations on Repair Costs of Low-Volume Highways, LTRC Report No. 228. Saber, Aziz; Morvant, Mark J.; Zhang, Zhongjie. USDOT. 2009. <a href="http://docs.trb.org/prp/09-0228.pdf">http://docs.trb.org/prp/09-0228.pdf</a>	Truck Study; Fatigue
	<b>Abstract:</b> The economic impact of overweight permitted vehicles hauling sugar cane on Louisiana highways is evaluated. The highway routes that are used to haul this commodity are identified and statistical samples are selected and analyzed. Two different vehicle types and three different gross vehicle weights are chosen including 100,000-lb. and 120,000-lb. AASHTO design guidelines are used to determine the effects of heavy loads on pavements and bridges. The approach requires the overlay thickness needed to carry traffic from each gross vehicle weight for the design period and costs based on 20-year period. The state bridges are evaluated to satisfy regulations for the loading requirements and a fatigue cost is estimated for each safe crossing of a bridge.		
	In addition, for documents referencing Methods and Impacts of Bridge Fatigue Limit State see "Reference Nos.": 2.3.46; 2.1.6-14; 2.1.6-16; 2.1.6-22		

## **2.3 Methods and Models Related to Accrued Bridge Damage Costs and Bridge Serviceability Limits**

### **2.3.1 Introduction**

The bridge team was tasked to conduct a study of the potential effects of the general legalization of the 2014 CTSW Study six (6) Alternative Truck Configurations (Scenarios) on bridges on the National Highway System (NHS) and the National Truck Network (NN), and by inclusion specifically on the Interstate System (IS). The scope of this sub-study area focuses on the serviceability related impacts on the existing bridge inventory, and the bridge capital cost effects that would accrue over time due to resulting bridge damage.

### **2.3.2 A survey of analysis methods and a synthesis of the state of practice**

Historically, there has been a large volume of studies and research related to truck size and weight and attempts by agencies, university academics and consultants to determine means and methods to assign cost responsibility for infrastructure investments to a diverse set of roadway users. The breadth of these studies, diverse interests and funding levels by the supporting agencies make them a challenge to compare. Various studies were employed to answer fundamentally different questions. A lack of consensus on methodologies and on the parameters studied has had a detrimental effect on the consistency of the results and has severely limited the possible conclusions. The research team started with existing literature references that were

previously identified in the course of the Washington, DC, District of Columbia DOT (DDOT) Truck Size and Weight Study, titled “District-wide Truck Safety Enforcement Plan”, May 2010, KLS Engineering and Wilbur Smith Associates (CDM Smith). The team drilled down through the bibliographies to find additional sources of information, and used various search engines on the world-wide web. We also identified domestic and foreign universities’ and transportation agencies’ web sites to obtain more data and information. Finally the team used CDM Smith’s Internal Library System to find and obtain additional literature and articles. With our subscription to the ASCE journals and access to the Knovel Online Library we were able to obtain archived or proprietary studies. A few other resources were provided as a result of research conducted by the other internal Task Teams engaged in this current 2014 CTSW Study.

The following provides a brief history of the most relevant documents found.

### ***2.3.2.1 Other Cost Methodologies***

A number of different cost allocation methodologies have been reviewed. The most prevalent method used in the United States in the recent past (1997-2012) has been the ‘Federal Method’, as described in NCHRP Report 495 (2003) – “Effect of Truck Weight on Bridge Network Costs”, which was derived from the 1997 FHWA Highway Cost Allocation Study. Both of these documents are a refinement of the previous incremental methods developed in the 70’s and 80’s. The Federal Method was developed for use by individual states and/or local highway network authorities and has not been adapted to national or even regional studies. To implement the Federal Method on a national scale would require a level of detail not available in the National Bridge Inventory (NBI) or not available in a consistent format, and potentially not available at all. The required information includes: detailed structural data for each bridge; bridge specific condition data; current detailed cost/expenditure data; and WIM data specifically applicable to the bridges. The various states have different policies and procedures as they relate to bridge preservation, rehabilitation and replacement. It would be extremely difficult to reflect all of those policy differences in such a national study.

States have used the Federal Method in modified formats to allocate bridge costs along with varied allocators (Vehicle Miles Traveled (VMT), Passenger Car Equivalent (PCE), Passenger Car Units (PCU), Average Gross Mass (AGM) or Equivalent Single Axle Load (ESAL)) for different bridge elements and for various other bridge related costs. It should be stressed that there has been no uniformity or consensus in regard to what is included in a bridge cost allocation study. Perhaps most importantly, the states have designed the methodologies used in those studies to answer their different questions. The Federal Method cannot generate cost allocation at the level of detail envisioned under this 2014 CTSW Study, or with a similar degree of transparency as one would hope to have for a study of this national scale. However, some aspects of the Federal Method, as set forth in NCHRP Report 495 (2003) might augment other models or approaches.

Two reports chronicle previous U.S. cost responsibility efforts. NCHRP Synthesis 378 (2008) provides a detailed history of U.S. based cost allocation studies by state from the early 1940’s

through 2008. NCHRP 20-07 Task 303 (2011), “Directory of Significant Truck Size and Weight Research” is similar to the Synthesis 378 report but adds additional studies through 2011.

Vermont Pilot Program Study (2012): Under Vermont Public Law 111-117, the State raised truck size and weight limits on its Interstate System (IS) for a period of one year, beginning in December, 2009. The state allowed the 99,000 pound, six-axle trucks that were operating on Vermont’s State Highway System to be on the State’s 280 miles of interstate highways and on the affected 265 bridges. The method involved estimating the fatigue lives of the 23 steel bridges for a baseline Control Loading with trucks in the existing fleet and then comparing it to the fleet of trucks (including the 99,000 lb. pilot study truck) representing the year 2010. A similar study of longer duration with a calibration of the limit state to the recognized service life of the bridges might yield another cost allocation approach.

Methodologies used in Europe and Australia were also reviewed. The European Union (E.U.) Cost Allocation of Transport Infrastructure (CATRIN, 2008) synthesis document is a summary of methods of cost allocations used in the transportation industry (including roadways, railway, air transport and maritime) in Europe. Countries submitting studies included Austria, the UK, Belgium, Denmark, Finland, Germany, Poland, the Netherlands, Sweden and Switzerland. They approach the allocation of roadway costs (including bridges) from an econometric or “top-down” approach as well as from an engineering or “bottom-up” approach. What is clear from this document is that there is a huge disparity of approaches between these countries due to: data type, cost categories and elements, etc. In the end the document does not sum up the cost responsibilities from each country, but rather summarizes the ‘approaches’ in tabular form. So, all we can surmise from this tabular matrix is that in some cases load based allocators were used for highway cost allocation, including for bridges (either directly or in-directly). The Netherlands and Switzerland used them on their roadways and then broke out bridges as a percentage of overall costs. In Finland they used them directly in their bridge cost allocation. As far as we understand it, no new engineering methods were introduced, except for in Germany (the Maut Study) which used a “Club” type approach, applying PCEs. Another observation is that the number of vehicle classes used in the cost responsibility procedures shows a great variance among the countries, ranging from 6 to as many as 27 (Netherlands), 30 (Switzerland), and 37 (United Kingdom) vehicle classes.

The Australian Method, as reported in the National Transport Commission’s ‘Third Heavy Vehicle Road Pricing Determination Technical Report’ (October 2005), uses a number of allocators to determine shares of vehicle cost responsibility. The study lumps all costs under “roadway” costs and then breaks out pavement and bridge costs. Bridge costs are compiled from the various regional transport industries and are categorized as Attributable and Non-attributable Costs. Original and new construction costs of bridges are considered as Non-attributable costs, and are allocated by vehicle usage or Vehicle Kilometers Travelled (VKT). These costs were estimated at 85% of all bridge costs. As we understand it, for them Attributable Costs include preservation and maintenance, repairs and rehabilitation. The Attributable bridge cost, estimated at 15% of all costs, was allocated based on Passenger Car Equivalent Units (PCUs). The Australian report acknowledged that there was a relationship between load based allocators and

bridge deterioration, but it stopped short of suggesting a method other than using PCUs. The report states “For other non-pavement expenditure (i.e., bridge) categories, there is little international consensus, and little information on which to judge to what extent alternative approaches might be applicable to Australia.” In other words the Australian report does not endorse any other method for allocating bridge costs.

In summary, the following results were developed:

- In the U.S. no nation-wide studies had been done to-date purely of bridge costs utilizing a load-induced cost responsibility allocator.
- Internationally, there has been little consistency of data across states or other political boundaries.
- In part due to the lack of uniform data collection policies, there has also been little consistency in the methodologies used by the various agencies for assigning cost responsibilities across states (or provinces) and other political boundaries.
- These studies have used various metrics to help apportion, allocate or assign costs to the various truck classifications. The pros and cons of these metrics can be described as follows:

#### 2.3.2.1.1 Weigh-in-Motion (WIM) Data

The initial data records include station description, traffic volume and count, speed data, vehicle classification based on the Highway Performance Monitoring System, HPMS), and weight data.

The data provides axle load estimates and counts including frequency and magnitude. Every state monitors movement of trucks, which makes the data readily available and standardized as reported to the FHWA. The data provides detail for HPMS Vehicle Classification by Highway Classification.

However, there are drawbacks to using WIM data. As stated above, the initial raw data provides a lot of the basic information needed. It cannot be used in its raw form since the data is highly fragmented and must be processed by scrubbing, aggregating and weighting (by other parameters such as VMTs) and translated into a usable format. In this final format much of the original detail may have been altered. For example, truck counts are collected at individual stations. However, these are only a snapshot of the data for a given day and hour of data collection. Different stations in the state may collect data at different times so as the data is aggregated there will be gaps and overlaps. In order to compensate for these inconsistencies, the data are processed with subroutines to derive a sub-data set that represents the truck traffic stream in a given state.

#### 2.3.2.1.2 Vehicle Miles Traveled (VMT)

VMT is a metric which is an indicator of the travel levels on the roadway system by motor vehicle class. VMT's are estimated for the given time period that is based upon traffic volume counts and roadway length. This metric has been used as one of many allocator types to estimate consumption of wearing surfaces on pavements and bridge decks.

The problem with VMT as an allocator by itself is that it assumes equal consumption based on the relative miles traveled and does not account for the vehicle weight. For example in applying VMT it is assumed that a 3500 pound car consumes the same stretch of pavement as an 80,000 lb. 5-axle (3-S2) tractor semitrailer for the same distance traveled. Another problem with VMT is more specific to bridges; we would be assuming that bridges are distributed proportionally to the number of highway miles. However, we know that the bridge density (length of bridges and their count) per mile of highway varies geographically based on rural and urban environments, and on the number of water crossings and overpasses of intersecting roadways.

#### 2.3.2.1.3 Passenger Car Equivalents (PCE)

PCE is a metric which equates any of the HPMS vehicle classes to a Passenger Car Equivalent or Unit (PCE or PCU) and is essentially the impact that a mode of transport has on traffic variables (such as headway, speed, density) compared to a single car. It is derived from taking a certain mixed traffic stream and heuristically or statistically converting it into a hypothetical passenger-car stream.

Similar to VMTs, PCEs do not take into account axle loads. As an allocator it might be more useful to estimate delays and backups that may occur at a certain location (such as a bridge under construction). But the PCE is more a capacity based allocator and cannot provide a suitable estimate of the physical load impacts those trucks would have on the bridge itself.

#### 2.3.2.1.4 Equivalent Single Axle Load (ESAL), Load Equivalency Factor (LEF)

The ESAL was originally derived in the 1940s after large trucks started to populate US highways and was introduced by AASHO (now AASHTO) in a rather complex formula that was based on a standard truck axle weight of 18,000 pounds. The premise was that the standard 18,000 lb. axle induced a unit of damage on pavement. The complex formula was eventually reduced to a more simple ratio of actual axle load divided by the standard axle (i.e., 18,000 pounds) raised to the 4th power or Load Equivalency Factor (LEF). Many transportation agencies in the US and Europe (CATRIN, 2008) used variations of this formula to estimate impacts to bridges and various power ratios were selected ranging from 2.0 to 4.0. Some agencies used the method directly to estimate pavement (highway) impacts and pulled out bridge costs simply as a percentage, while others applied the ESAL damage index directly to their bridges.

New pavement damage methodologies have been developed such as the Empirical-Mechanistic Pavement Models. In spite of this the ESAL/LEF methodology continues to be used by transportation agencies, because it provides a method of incorporating axle loads and frequency of occurrence to estimate pavement and bridge damage.

#### **2.3.2.2 Pros and Cons of Specific Cost Responsibility Assignment Methods**

##### 2.3.2.2.1 Incremental/Federal Method (as described in NCHRP Report 495, 2003)

The concept presented therein is rather simple however its implementation is very complex, and increasingly so for large systems. The cost impacts are categorized as 1) impact to existing bridge superstructures, 2) impact to new bridge superstructures, 3) impact to steel fatigue details and 4) impacts to reinforced concrete deck crack propagation (termed reinforced concrete fatigue

in Report 495). The method allows one to prescribe a course of action that has a certain cost to perform, but it does not provide for a measure of the actual level of damage. The effective use of this method requires a familiarity with each state's repair philosophies and practices. For instance, does the state lean towards repair and preservation or does it favor pro-active replacement of deficient structures? With respect to the fatigue methods described in this document, the document itself addresses its own limitations in that ... due to "uncertainty observed in reported physical test results and practice" in determining end of service life..." the real service life of the deck (for instance) is not certain." In this, the report recognizes the lack of available data in a consistent format, sufficient to implement its use for a large regional or national study. With respect to the term 'practice', they mean at what threshold visible condition level, do different owners determine that a deck has failed or that a specific intervention (action option) is warranted.

"The Federal...method is more advantageous at the state level or a local level [for which] cost impact estimation could be conducted in more detail, because more detailed bridge data are available and the number of bridges becomes smaller" (NCHRP Report 495, 2003). Conversely stated, the disadvantage of this method is that the level of detail and data needed to analyze bridges on a national scale would be time and cost prohibitive. The method provides bridge selection guidelines that may end up excluding representative bridges if there is a large population of bridges in the study area.

#### 2.3.2.2.2 KLS/Wilbur Smith Associates Study, Washington, DC DDOT, 2010 District Wide Truck Safety Enforcement Plan: Task 3 - Infrastructure Impacts of Overweight Trucks

The bridge cost allocation portion of this study was based on a model that utilized a bridge deterioration mechanism prevalent where states use chlorides in de-icing roadways and bridges. This study employed ESAL/LEFs as its allocator for estimating damage and assigning cost. District Axle Load Charts were used to determine which sets of axle weight increments would be considered compliant or non-compliant. Accordingly, a relative damage distribution profile was determined (by percent) of legal and over-weight trucks by vehicle class (HPMS Classes 4 through 13). Based on the literature review (Ohio DOT Impacts of Permitted Trucking on Ohio's Transportation System and Economy, Final Report of 2009, and the 1997 FHWA HCAS methodology), it was observed that between 59% to as much as 79% of bridge damage could be attributed to non-truck related (or non-load induced) factors. These would include environmental factors, site related conditions, usage patterns, age and the cumulative effects of light weight vehicles.

A detailed, annualized capital cost estimate was developed for the 139 of the District's non-parkway bridges that carry truck traffic. The truck distribution profile of the 10 truck vehicle classifications was applied to the annualized bridge costs providing a clear picture of the impact of trucks (both compliant and non-compliant) on the District's bridges.

This methodology utilized the ESAL/LEF allocator to assign cost responsibility, and this approach is somewhat flawed as it ties damage to an arbitrary standard axle load and to a powered exponent that was not well understood at the time.

This study was not published, but has been made available to FHWA and NAS reviewers by permission of the District Authority.

### ***2.3.2.3 South Carolina's 'Rate of Deterioration of Bridges and Pavements as Affected by Trucks'***

One recent (released in late 2014) addition to the desk scan was South Carolina's 'Rate of Deterioration of Bridges and Pavements as Affected by Trucks' report.

This report included the following:

- **Bridge Damage Model:** the authors modified AASHTO S-N curves and created a new curve called "Service-Level Fatigue Curve" for the "Giga-Cycle Low Stress Region" based on the 2005 Bathias and Paris giga-cycle fatigue study and on the 5 million cycle AASHTO limit, arguing that the number of fatigue cycles would be well beyond 5 million within the design life of 75 years per AASHTO assumptions. The fatigue details considered consisted of steel reinforcement in concrete decks and tendons in pre-stressed bridge members.
- **Cost Allocation Model:** the authors first calculated the maximum allowable fatigue cycles based on the new fatigue curve for each truck model, and on annual cycles for each truck model based on WIM Data, and then proportioned the annual cycle counts over the maximum allowable cycles to obtain annual bridge fatigue damage costs, then added the annual bridge maintenance cost to obtain the overall annual bridge damage cost. Shares of bridge damage cost for each truck model were proportioned based on the percentage of each truck's volume in the fleet.
- **Potential applications of the Study:** (1) the study establishes a new method of allocating bridge damage cost due to overweight trucks based on axle weight groups. The method could be a blueprint for other studies; 2) the South Carolina study concluded that the "bridge damage increased exponentially with an increase in truck weight", which supports CDM Smith's bridge damage model that is an exponential power formula.
- **Potential limitations of the study:** 1) In the bridge damage model, it is debatable that the slope of S-N curve in the Giga-Cycle Low Stress Region would be the same as that in the AASHTO High Cycle High Stress Region. There is insufficient data to verify this assumption; 2) it is also debatable that the bridge damage within the design life span is attributed to the reinforcement or pre-stressed tendon fatigue damage.

The most common deterioration in bridges is typically the prevalence of concrete spalls in decks that lead to major bridge rehabilitation and/or replacement. It's rare to observe rebar fracture failure due to fatigue, even at the end of the bridge design life span, but particularly within the design life. It's very common to have at least one full deck replacement due to deck failure, and the authors' equating the time frame of bridge replacement to that of bridge fatigue failure didn't consider this issue. It is logical to assume that the bridge will only exhibit damage after passing the 5 million cycle threshold, but the authors calculated the annual fatigue damage cost assuming that it would be same for every year in the design life span. The assumption is contradicted by



the bridge damage model. The South Carolina report allocated bridge damage costs based on miles traveled. But this didn't take into account variables such as bridge length, number of spans, and the number of bridges in a given mile. Finally, the authors didn't consider that the number of stress cycles might be different for each truck model on different bridges due to variance of bridge span lengths, number of spans, and truck axle configuration in the model. This last issue poses a limitation on evaluating the net effects due to a specific bridge.

In the South Carolina report bridge types studied were reduced to a few archetypes based on the predominant bridge types found in the state, with an emphasis on concrete vs. steel superstructures.

### **2.3.3 An identification of data needs and an evaluation and critique of data sources**

With respect to the Incremental/Federal Method, the process for all cost categories includes selecting a number of bridges in the region or state. These bridges would need to be load rated in accordance with AASHTO's Manual of Bridge Evaluation. To estimate the cost impact of the truck; if the rating factor is less than 1.0 the bridge is considered to be inadequate for the truck, and one of five action options could be selected: 1= do nothing, 2 = rehab or retrofit, 3 = post, 4 = combination of 2 and 3, 5 = replace. The cost of the action then is estimated for that truck on that type of bridge. The same general steps are repeated for the four cost categories with variations in the actual details.

Report 495 did introduce a 'probabilistic approach', a formulaic expression (Equations 3.4.2.7 and 3.3.3.1) to deal with the uncertainty with respect to reported physical test results and practice. (NCHRP Report 495, pages 46 and 51, Section 3.4.3). However, the amount of data required and the sheer scope of work relative to its application to large numbers of specific, real bridges is considered to be untenable at this time.

The KLS/WSA 2010 D.C. DDOT Truck Safety Enforcement Plan study used the NBI database to get most of the bridge data, minus the structural details. WIM data in the form of axle load weight increments and counts for each vehicle class was employed.

Data types and categories have varied greatly for the various studies reviewed, and at the time of this study there was a general lack of consistently formatted data throughout the various states. This has been referred to as the data gap issue. Quality and quantity of viable information in the format desired are inconsistent. The data (particularly WIM data) can be 'mined' and 'scrubbed' and often must be reconfigured to address the needs of a particular study.

### **2.3.4 An assessment of the current state of understanding of the impact and needs for future research, data collection and evaluation**

The FHWA is engaged in the development process for the Long Term Bridge Performance (LTBP) program, intended to provide a more detailed and timely picture of bridge health, improve knowledge of bridge performance, and lead to better bridge management tools.

**2.3.5 Quantitative results of past studies**

Numerous past studies having been reviewed, we can conclude the following:

- The differences in the methods employed, the parameters and allocators chosen, and the assumptions about the relationships between those parameters and bridge costs have yielded a plethora of results that simply don't lend themselves to direct comparison.
- U.S. DOT has confirmed their position, and the desk scan confirms, that there is presently no generally accepted methodology for deriving the bridge damage costs associated with trucks and most particularly with allocating shares of those costs to specific trucks in the traffic stream.
- A few of the study methods reviewed appear to have relative merit or potential, but all of them have limitations. They all include assumptions, the application of which introduces varying degrees of uncertainty and in some cases skepticism.

**2.3.6 List of References**

<b>Methods and Cost Impacts of Bridge Serviceability</b>			
<b>Reference No.</b>	<b>Document No.</b>	<b>Document Title and Link</b>	<b>Relevance to Study</b>
		<p><i>In this subsection cost allocation studies of 15 states are presented. Some states like Oregon conduct Highway Cost allocation studies biennially, however only the latest studies are shown herein. Indiana has conducted a 2013 HCAS, however their latest report is not available through the internet. There will be an ongoing effort to obtain that report (as well as others) as the methods and conclusions are of vital interest to this study.</i></p> <p><i>The majority of the US HCAS reports conducted by each state follow the Federal HCAS method recommended in 2003 with some modifications. The exception would be the Washington DC, District DOT Truck Size &amp; Weight Study, 2010 conducted by CDM will be used as a basis of this study. It should be noted that the Federal Cost Allocation Method for bridges has not been used on a nationwide basis and the data requirements presents considerable difficulties in expanding it to a national scale. The method was devised to provide uniformity for state and local agencies to conduct the studies on network of roads (toll road, trucking network) and could be expanded to the whole state if needed. California, Maryland and New York are states that have examined a limited network of roads. Most other states have studied a sampling of their bridges and extrapolated the results to the state-wide array of bridges.</i></p> <p><i>We have also included the Australian HCAS study and the European Union CATRIN study as they provide alternate views, means and methods for such studies. A discussion of these studies is provided in the Bridge Task Project Plan. In brief, the Australians conducted a nationwide highway cost allocation study but used Passenger Car Equivalent (PCE) and Vehicle Kilometers Traveled (VKT) as the basis for the bridge cost share allocator. The European Cost Allocation Report (CATRIN) was a compilation of cost allocation studies conducted independently by 15 European Union countries on their roadway (and other transportation) networks. Our focus was on the bridge costs and the allocators used to proportion out cost responsibilities. What was apparent was that only a handful of countries like the Finland, Switzerland, the Dutch tracked bridge costs separate. In each case the same allocator (Load related allocator – ESALs or ESAL KM) that was used on the pavements was also applied to the bridges. A few countries like Germany approached the allocation problem from a Top-Down or Econometric method as well</i></p>	

<b>Methods and Cost Impacts of Bridge Serviceability</b>			
Reference No.	Document No.	Document Title and Link	Relevance to Study
	<p><i>as using Engineering type allocators like PCEs and VKTs.</i></p> <p><i>What is clear from all of the foreign studies was the difficulty in obtaining data in a uniform format across political boundaries and what cost items (construction, rehabilitation, maintenance, etc.) to include or exclude from the studies. Although the US Federal method provides a uniform method for cost allocation, the states use the cost data in the format that they are used to collecting and there is no standardization.</i></p>		
2.3.6-1	TRB 1990a (SR 225)	Special Report 225: Truck Weight Limits: Issues and Options. National Research Council, Washington, D.C., 1990	CTSW
2.3.6-2	TRB 1990b (SR 227)	Special Report 227: New Trucks for Greater Productivity and Less Road Wear: An Evaluation of the Turner Proposal. National Research Council, Washington, D.C., 1990	CTSW
<p><i>The thrust of both the TRB 1990a and TRB 1990b documents with respect to bridges was the speculation that the one-time cost for upgrading bridge superstructures due to the heavier Turner Trucks would be cost prohibitive to the states.</i></p>			
2.3.6-3	CTSW 2000 Volumes 1-4	Comprehensive Truck Size and Weight Study: Volume 1-4, USDOT – Office of Transportation Policy Studies; <a href="http://www.fhwa.dot.gov/policy/otps/truck/finalreport.htm">http://www.fhwa.dot.gov/policy/otps/truck/finalreport.htm</a>	Historical Context & Commentary
<p>The Comprehensive Truck Size and Weight Study began in 1994 along with a companion study, the Federal Highway Cost Allocation Study that was submitted to Congress in August, 1997.</p> <p>The objectives of the 2000 Comprehensive Truck Size and Weight (CTS&amp;W) Study were to:</p> <ol style="list-style-type: none"> <li>(1) Identify the range of issues impacting TS&amp;W considerations;</li> <li>(2) Assess current characteristics of the transportation of various commodities including modes used, the predominant types of vehicles used, the length of hauls, payloads, regional differences in transportation characteristics, and other factors that affect the sensitivity of different market segments of the freight transportation industry to changes in TS&amp;W limits; and</li> <li>(3) Evaluate the full range of impacts associated with alternative configurations having different sizes and weights.</li> </ol> <p><i>The document forms a historical basis for the current CTSW study and a basis for understanding on going issues with respect to trucks and bridges. Some of the goals were common with the 2014 CTSW Study, however many of the bridge related studies included in it were designed to answer a different question. A Highway Cost Allocation Method that included a modified “Incremental” method along with several interlinked spreadsheets had been introduced in 1997. This was called the Federal Incremental Method. Neither a nationwide nor regional bridge allocation study was provided, although some local examples of bridge allocation studies were included. In 2003 the Federal Bridge Cost Allocation Method was re-introduced in NCHRP Report 495 Based on our research a true national bridge cost allocation has not been done.</i></p>			
2.3.6-4	FHWA-IF-05-040	Transportation Asset Management Case Studies; Office of Asset Management <a href="http://www.fhwa.dot.gov/infrastructure/asstmgmt/bmcs701.cfm">http://www.fhwa.dot.gov/infrastructure/asstmgmt/bmcs701.cfm</a>	Bridge Management, PONTIS
<p>This document is a case study covering several states that use the AASHTOWare PONTIS</p>			

<b>Methods and Cost Impacts of Bridge Serviceability</b>			
Reference No.	Document No.	Document Title and Link	Relevance to Study
		<p>software (initially developed by FHWA) in their asset management practices. The Federal Highway Administration Office of Asset Management is promoting a different way for transportation agencies to distribute their resources among alternative investment options. This new way of doing business, "Asset Management," is a strategic approach for getting the best return on dollars spent for transportation improvements.</p> <p>Each State transportation agency will likely have different methods for implementing an Asset Management strategy. For example, some agencies will pursue a data integration strategy in order to ensure comparable data for the evaluation of investment alternatives across asset classes. Others will move to deploy economic analysis tools to generate fact-based information for decision-makers. Still others will want to integrate new inventory assessment methods into their decision-making process.</p> <p>Pontis® is a comprehensive bridge management system tool developed to assist in the challenging task of bridge management. Initially developed by FHWA, Pontis® now is an AASHTOWare Bridge Management® product. It stores bridge inventory and inspection data; presents network-wide preservation and improvement policies for use in evaluating the needs of each bridge in a network; and makes recommendations for what projects to include in an agency's capital improvement program for deriving the maximum benefit from limited funds. The software is continuously upgraded and improved based on various users' input.</p>	
2.3.6-5	FHWA - IF - 11-016	<p>Framework for Improving Resilience of Bridge Design; Turner Fairbanks Transportation Research Center, Long Term Bridge Performance</p> <p><a href="http://www.fhwa.dot.gov/bridge/pubs/hif11016/hif11016.pdf">http://www.fhwa.dot.gov/bridge/pubs/hif11016/hif11016.pdf</a></p>	Long Term Bridge Performance
		<p>This document provides a framework for bridge engineers to design and build more robust and resilient bridges that are resistant to the forces of nature as well as to the ever growing truck numbers and sizes that frequent the nation's highways.</p>	
2.3.6-6	FHWA-HRT-11-037	<p>FHWA LTBP Workshop to Identify Bridge Substructure Repairs; Turner Fairbanks Transportation Research Center, Long Term Bridge Performance</p> <p><a href="http://www.fhwa.dot.gov/publications/research/infrastructure/structures/ltbp/11037/index.cfm">http://www.fhwa.dot.gov/publications/research/infrastructure/structures/ltbp/11037/index.cfm</a></p>	Long Term Bridge Performance
		<p>The purpose of this workshop was to consider overall bridge performance and identify geotechnical performance metrics that may correspond to good and poor performance. This report describes the results of the workshop and presents them in the larger perspective of designing and implementing the LTBP program. This document will be of interest to engineers who research, design, construct, inspect, maintain, and manage bridges as well as to decision-makers at all levels of management of public highway agencies.</p>	
2.3.6-7	NCHRP SYN 397	<p>NCHRP Synthesis 397: Bridge Management Systems for Transportation Agency Decision Making; 2009; Markow, Michael J.; Hyman, William A.</p> <p><a href="http://onlinepubs.trb.org/onlinepubs/nchrp/nchrp_syn_397.pdf">http://onlinepubs.trb.org/onlinepubs/nchrp/nchrp_syn_397.pdf</a></p>	Bridge Management
		<p>The objective of this synthesis study has been to gather information on current practices that agency chief executive officers and senior managers use to make network-level investment and</p>	

<b>Methods and Cost Impacts of Bridge Serviceability</b>			
Reference No.	Document No.	Document Title and Link	Relevance to Study
		<p>resource allocation decisions for their bridge programs, and to understand how they apply their agency’s bridge management capabilities to support these decisions. The following areas of planning, programming, and performance-based decision making have been addressed. Condition and performance measures that are used to define policy goals and performance targets for the bridge program are:</p> <ul style="list-style-type: none"> <li>• Methods of establishing funding levels and identifying bridge needs</li> <li>• Methods and organizational responsibilities for resource allocation between the bridge program versus competing needs in other programs (pavement, safety, etc.)</li> <li>• Methods of allocation among districts and selection and prioritization of projects</li> <li>• The role of automated bridge management systems (BMS) in planning, programming, resource allocation, and budgeting</li> <li>• Use of economic methods in bridge management</li> <li>• Methods to promote accountability and communication of the status of the bridge inventory and the bridge program</li> </ul>	
2.3.6-8	NCHRP Rpt 668	<p>NCHRP Report 668:Framework for a National Database System for Maintenance Actions on Highway Bridges, Principal Investigator: George Hearn, (University of Colorado), Paul Thompson, Walter Mystkowski, William Hyman, (Applied Research Associates), 2010  <a href="http://onlinepubs.trb.org/onlinepubs/nchrp/nchrp_rpt_668.pdf">http://onlinepubs.trb.org/onlinepubs/nchrp/nchrp_rpt_668.pdf</a></p>	Bridge Asset Management
		<p>This report presents a potential framework for a National Bridge Maintenance Database (NBMD). This framework provides a uniform format for collecting, reporting, and storing information on bridge maintenance actions. Use of this framework could promote compatibility of maintenance data reported by different agencies and will provide an effective means for using these data in evaluating cost and performance of alternative maintenance applications or as a basis for cost-benefit analysis and evaluation of cost and deterioration models. The material contained in the report should be of immediate interest to state bridge and maintenance engineers and others concerned with the maintenance and management of bridges.</p> <p>In terms of standardizing owner agency bridge maintenance and preservation practices and cost reporting, this documentation has made advances. This type of data is of great interest to both bridge owners and others who may utilize and analyze the data for a variety of cost purposes. These may be for evaluating the cost effectiveness of a program or using it for cost allocation studies. It should be noted that standardization of cost reporting is still premature and owner agencies have to buy into the benefits of conforming to the standards. This program could be a great source of data that could be readily available.</p>	
2.3.6-9	CDOT 2012-4	<p>Deterioration and Cost Information for Bridge Management; 2012; George Hearn, University of Colorado  <a href="http://www.coloradodot.info/programs/research/pdfs/2012/pontis.pdf/view">http://www.coloradodot.info/programs/research/pdfs/2012/pontis.pdf/view</a></p>	Bridge Management, PONTIS
		<p>Abstract:</p> <ul style="list-style-type: none"> <li>• Study 87-60 uses contract bid tabulations and element-level condition records to develop element-level actions, costs for actions, transition probabilities for models of deterioration</li> </ul>	

<b>Methods and Cost Impacts of Bridge Serviceability</b>			
Reference No.	Document No.	Document Title and Link	Relevance to Study
		<p>of bridge elements, and transition probabilities for improvements to elements due to actions. The information on actions, costs, and transition probabilities are input to a Pontis BMS bridge database.</p> <ul style="list-style-type: none"> <li>• Study 87-60 applies transition probabilities for element deterioration to compute the number of years to possible loss of safety in bridges, and to compute the number of years for inspection intervals.</li> <li>• Study 87-60 examines variations among CDOT regions of costs of actions and of deterioration of elements.</li> <li>• Study 87-60 developed a set of software applications to handle bid tabulations, compute costs of actions, compute transition probabilities, and mediate the steps needed for movement of data into and out of PONTIS BMS.</li> </ul>	
2.3.6-10	USDOT PUB	<p>Bridge Preservation Guide; FHWA Office of Infrastructure;  <a href="http://www.fhwa.dot.gov/bridge/preservation/guide/guide.pdf">http://www.fhwa.dot.gov/bridge/preservation/guide/guide.pdf</a></p>	Bridge Preservation
		<p>This guide provides bridge related definitions and corresponding commentaries, as well as the framework for a systematic approach to a preventive maintenance (PM) program. The goal is to provide guidance on bridge preservation.</p>	
2.3.6-11	SHRP 2 PREPUB R19A	<p>Design Guide for Bridges for Service Life; 2012; Principal Investigator: Atorod Azizinamini, Ph.D., P.E.; Florida International University, HDR Engineering, etc.</p>	Deterioration Models, Bridge Design
		<p>The main objective of the Guide is to provide information and define procedures to systematically design for service life and durability for both new and existing bridges. The objective of the Guide is to equip the user with knowledge that is needed to develop specific optimal solutions for a bridge under consideration in a systematic manner using a framework that is universal, but with specifics being different. The general frame work for design for service life is described, followed by addressing specifics related to each step by topics covered in various chapters.</p> <p><i>In developing our bridge cost allocation method, we utilized a deterioration model based on our own experience and observations collected while inspecting thousands of bridges in the Northeast Region of the United States. The first step is understanding bridge behavior; the deterioration mechanism and the interaction of each element. Based on an understanding of bridges through extensive bridge inspection and rehabilitation design, the development of a deterioration model is at this point rather intuitive. Based on review of this document, it is evident that a scientific approach is being proposed using the engineering community's collective knowledge base. The R19A document provides a scientific method to enhance the service life of bridges. It is a major shift in thinking for bridge design and preservation. New design methods are being proposed as a result of understanding how bridges deteriorate over time. It should be noted that this document is a work in progress and is being updated.</i></p>	
2.3.6-12	SHRP 2 S2-R19A- RW-1	<p>Bridge for Service Life Beyond 100 Years Innovative Systems, Subsystems and Components, Atorod Azizinamini, Ph.D., P.E.; Florida International University, HDR Engineering, etc.  <a href="http://onlinepubs.trb.org/onlinepubs/shrp2/SHRP2_S2-R19A-RW-1.pdf">http://onlinepubs.trb.org/onlinepubs/shrp2/SHRP2_S2-R19A-RW-1.pdf</a></p>	Deterioration Models, Bridge Design
		<p>The Service Life Design Guide is a new reference volume that addresses design, fabrication, construction, operation, maintenance, repair, and replacement issues for both new and existing</p>	

<b>Methods and Cost Impacts of Bridge Serviceability</b>			
Reference No.	Document No.	Document Title and Link	Relevance to Study
		bridges. The Guide provides information and procedures to systematically design new and existing bridges for the service life and durability. It includes a framework for service life design and has 11 chapters, and 7 appendices each devoted to a certain bridge part or aspect of the service life design process.	
2.3.6-13	SPR-P1 (11) M302	Developing Deterioration Models for Nebraska Bridges; Nebraska Department of Roads (NDOR), University of Nebraska, Lincoln, George Morcou, July 2011 <a href="http://www.transportation.nebraska.gov/mat-n-tests/research/BridgeOther/Final%20Report%20M302.pdf">http://www.transportation.nebraska.gov/mat-n-tests/research/BridgeOther/Final%20Report%20M302.pdf</a>	Deterioration Models, Bridge Decks
		<p>Nebraska Bridge Management System (NBMS) was developed in 1999 to assist in optimizing budget allocation for the maintenance, rehabilitation and replacement needs of highway bridges. This requires the prediction of bridge deterioration to calculate life-cycle costs. The approach tries to predict the deterioration of bridge components based on national average deterioration rates but does not account for the impact of traffic volume, structure and material type, and environment impacts, in addition to being not specific to Nebraska bridges. The objective of this project is to develop deterioration models for Nebraska bridges that are based on the condition ratings of bridge components (i.e. deck, superstructure, and substructure).</p> <p>Recently, NDOR decided to migrate to AASHTOWare PONTIS software, to avoid the frequent updates of NBMS and stream line the data gathering process. PONTIS requires the use of a specific type of deterioration models with Transition Probability Matrices (TPM), which were not available for Nebraska bridges. Therefore, another objective of this project was to develop TPMs to customize the PONTIS deterioration models using the inventory and condition data readily available from the NBMS database. Procedures for updating and customizing the deterioration model were presented.</p> <p><i>This report highlights two areas that state agencies are grappling with. Proprietary type, legacy databases that have been used to develop predictive deterioration models to better manage infrastructure assets. On the other hand the agencies are struggling to migrate these databases to more nationally utilized and standard Bridge Information and Management systems such as PONTIS. In this case the NBMS data was successfully migrated and incorporated in TPMs for better predictive modeling. The migration process is on-going throughout the US. With respect to bridge decks it establishes a relative time frame where bridge components such as decks reach the end of their service life in comparison to the bridge service life.</i></p> <p><i>The more important finding of this study is that there is a strong correlation between Average Daily Truck Traffic (ADTT) and bridge deck deterioration (ratings) over time (Section 4.2.2.2, page 64). The data shows a rather steady decline in the early years, followed by a sharp decline in the later years, indicating a non-linear behavior.</i></p>	
2.3.6-14	NCHRP SYN 234	Settlement of Bridge Approaches (The Bump at the End of the Bridge); 1997; Briaud, Ph.D., P.E, Jean-Louis; James, Ph.D., P.E., Ray W.; Hoffman, Stacey B.; Texas A&M University; <a href="http://trid.trb.org/view.aspx?id=482992">http://trid.trb.org/view.aspx?id=482992</a>	Bridge Design, Settlement, Deterioration Mechanisms
		This synthesis describes the current state of practice for the design, construction, and maintenance of bridge approaches to reduce, eliminate, or compensate for settlement at the bridge/abutment/embankment interface or the bump at the end of the bridge. It discusses the	

<b>Methods and Cost Impacts of Bridge Serviceability</b>			
Reference No.	Document No.	Document Title and Link	Relevance to Study
		<p>geotechnical and structural engineering design and procedural factors, and includes numerous illustrations. This report of the Transportation Research Board presents data obtained from a review of the literature and a survey of the state DOTs. It is a supplemental update to Synthesis of Highway Practice 159: Design and Construction of Bridge Approaches (1990). The synthesis identifies and describes techniques that have been used to alleviate the problem of the bump at the end of the bridge including the location and cause of settlement and methods used to reduce settlement. In addition, the types of interaction between various divisions of the DOTs in the design, construction, and maintenance of bridge approaches are addressed.</p> <p><i>This synthesis was used as part of a comprehensive formulation of the Northeast Region deterioration model used (by CDM Smith Associates in 2010) for the District of Columbia Truck Size and Weight Study. The premise of the deterioration model was the progressive failure mechanism initiated by failure of the bridge deck joints. One key reason for the deck joint failure is settlement of the approach slabs. In turn the settlements would cause impact onto the bridge deck joint itself causing the header beams to crack, armor plating to separate or seals to fail. In either case this was an initial entry point for water intrusion into and below the bridge deck which caused deterioration of the beams, bearing and bridge seats/pedestals.</i></p>	
2.3.6-15		<p>Truck Loads and Highway Bridge Safety: New Developments; Gongkang Fu, Center for Advanced Bridge Engineering, Wayne State University; 2002  <a href="http://www-personal.umich.edu/~nowak/Papers/Fu,%20paper%201-6-03.pdf">http://www-personal.umich.edu/~nowak/Papers/Fu,%20paper%201-6-03.pdf</a></p>	Cost Allocation, Modal Shift
		<p>Abstract: This paper reports on some latest developments in efforts to balance truck loads and the capacity of highway bridges that carry the loads. One of them is the completion of the development of a method for estimating effects of truck weight limit change on bridge network costs, funded by the US National Cooperative Highway Research Program (NCHRP). Four categories of cost impact are addressed in this new method: steel fatigue, reinforced concrete (RC) deck fatigue, inadequate existing bridges, and higher design load for new bridges. This development has taken into account the constraints on data availability at the State infrastructure system level. Another recent development is the completion of a research effort examining the adequacy of bridge design load for the State of Michigan in the US, with respect to real truck loads measured. It was found that there is a need to develop a more rational design load to cover the risk represented. These developments offer effective tools for response to the trend of increasing truck loads.</p> <p><i>This article was quoted in the reference section of NCHRP Report 495. It is the main methodology used by Report 495 for utilizing the truck spectra (from WIM data) to predict truck load shift from one truck load fleet to another. As such it is a valuable document as we proceed with bridge cost allocation study.</i></p>	
2.3.16	SHRP2 S2-C20-RR-1	<p>Freight Demand Modeling and Data Improvement; 2013; Chase, Keith M. Chase, Anater, Patrick; Gannett Fleming, Inc. Phelan, Thomas; Eng-Wong, Taub and Associates  <a href="http://onlinepubs.trb.org/onlinepubs/shrp2/SHRP2_S2-C20-RR-1.pdf">http://onlinepubs.trb.org/onlinepubs/shrp2/SHRP2_S2-C20-RR-1.pdf</a></p>	Freight Demand; Modal Shift
		<ul style="list-style-type: none"> <li>Determine freight demand modeling and data needs, in part by defining an optimal scenario or desired future state of what the freight planning process should be with all of the model</li> </ul>	



<b>Methods and Cost Impacts of Bridge Serviceability</b>			
Reference No.	Document No.	Document Title and Link	Relevance to Study
		<p>parameters clearly identified and the necessary data available.</p> <ul style="list-style-type: none"> <li>Identify and promote innovative research efforts to help develop new modeling and data collection and processing tools in the near and long-term future.</li> <li>Establish and strengthen links between freight transportation planning tools and supporting data, and also consider the relationships between freight transportation and other areas of public interest, such as development and land use, in which freight movement has major implications.</li> <li>Leverage and link existing practices, innovations, and technologies into a feasible approach for improved freight transportation planning and modeling.</li> </ul> <p>Establish a recognized and regular venue to promote and support innovative ideas, modeling methods, data collection, and analysis tools as the basis for informing and sustaining further research.</p>	
2.3.6-17	NCFRP RPT 22	<p>NCFRP Report 22: Freight Data Cost Elements; 21013, José Holguín-Veras, Jeffrey Wojtowicz, Carlos González-Calderón, Rensselaer Polytechnic Institute, Troy, NY                      Michael Lawrence, Jonathan Skolnik, Michael Brooks, Shanshan Zhang, Jack Faucett Associates, Inc., Bethesda, MD                      Anne Strauss-Wieder, A. Strauss-Wieder, Inc., Westfield, NJ                      Lóri Tavasszy, TNO, Delft, Netherlands  <a href="http://onlinepubs.trb.org/onlinepubs/ncfrp/ncfrp_rpt_022.pdf">http://onlinepubs.trb.org/onlinepubs/ncfrp/ncfrp_rpt_022.pdf</a></p>	Freight, Cost Allocation
		<p>NCFRP Project 26, “Freight Data Cost Elements,” had the following objectives:</p> <ul style="list-style-type: none"> <li>Identify the specific types of direct freight transportation cost data elements required for public investment, policy, and regulatory decision-making; and</li> <li>Describe and assess different strategies for identifying and obtaining these cost data elements</li> </ul>	
2.3.6-18	ASCE JBENF 2_13_6_556	<p>Impact of Commercial Vehicle Weight Change on Highway Bridge Infrastructure; G. Fu; J. Feng; W. Dekelbab; F. Moses; H. Cohen; and D. Mertz; ASCE Journal of Bridge Engineering  <a href="http://ascelibrary.org/doi/pdf/10.1061/%28ASCE%291084-0702%282008%2913%3A6%28556%29">http://ascelibrary.org/doi/pdf/10.1061/%28ASCE%291084-0702%282008%2913%3A6%28556%29</a></p>	Freight - Over Weight Truck Study
		<p>Truck weight limit is one of the major factors affecting bridge deterioration and expenditure for maintenance, repair, and/or replacement. Truck weight in this paper not only refers to the truck gross weight but also to the axle weights and spacings that affect load effects. This paper presents the concepts of a new methodology for estimating cost effects of truck weight limit changes on bridges in a transportation infrastructure network. The methodology can serve as a tool for studying impacts of such changes. The resulting knowledge is needed when examining new truck weight limits, several of which have been and are still being debated at both the state and federal levels in the United States. The development of this estimation method has considered maximizing the use of available data such as the bridge inventory at the state infrastructure system level. In application examples completed but not reported herein, the costs for relatively inadequate strength of existing bridges and for increased design requirement for new bridges were found dominant in the total impact cost.</p>	
<b>Arizona</b>			
2.3.6-19	FHWA-AZ-	Estimating the Cost of Overweight Vehicle Travel on Arizona	

<b>Methods and Cost Impacts of Bridge Serviceability</b>			
Reference No.	Document No.	Document Title and Link	Relevance to Study
	06-528	Highways; Sandy H. Straus' ESRA Consulting Corporation <a href="http://azmemory.azlibrary.gov/cdm/ref/collection/statepubs/id/3603">http://azmemory.azlibrary.gov/cdm/ref/collection/statepubs/id/3603</a>	
2.3.6-20	FHWA-AZ99-477(1)	1999 Update of the Arizona Highway Cost Allocation Study; Arizona Department of Transportation; Carey, Jason; <a href="http://www.azdot.gov/TPD/ATRC/publications/project_reports/PDF/AZ477(1).pdf">http://www.azdot.gov/TPD/ATRC/publications/project_reports/PDF/AZ477(1).pdf</a>	
2.3.6-21	FHWA-AZ99-477(3)	Implementation of the Simplified Arizona Highway Cost Allocation Study Model; Arizona Department of Transportation; Carey, Jason <a href="http://www.azdot.gov/ADOTLibrary/publications/project_reports/PDF/AZ477(3).pdf">http://www.azdot.gov/ADOTLibrary/publications/project_reports/PDF/AZ477(3).pdf</a>	
<b>Idaho</b>			
2.3.6-22	023-2010 Idaho HCAS	2002 Idaho Highway Cost Allocation Study; SYDEC, Inc.; R.D. Mingo Associates; Harry Cohen Consultants; <a href="http://itd.idaho.gov/taskforce/resources/1040-Cost%20Allocation%202002.pdf">http://itd.idaho.gov/taskforce/resources/1040-Cost%20Allocation%202002.pdf</a>	
2.3.6-23	017-2010 Idaho HCAS	2010 Idaho Highway Cost Allocation Study Final Report; Battelle; P Balducci; J Stowers; R Mingo; H Cohen; H Wolff; <a href="http://itd.idaho.gov/taskforce/2010%20Idaho%20HCAS%20Final%20Report_Oct%2024.pdf">http://itd.idaho.gov/taskforce/2010%20Idaho%20HCAS%20Final%20Report_Oct%2024.pdf</a>	
<b>Indiana</b>			
2.3.6-24	FHWA/IN/J HRP-89/4	1988 Update of the Indiana Highway Cost Allocation Study; Sinha, K.C.; Saha, S. K.; Fwa, T.F.; Tee, A.B.; Michael, H.L.; Joint Transportation Research Program; <a href="http://docs.lib.purdue.edu/cgi/viewcontent.cgi?article=2510&amp;context=jtrp">http://docs.lib.purdue.edu/cgi/viewcontent.cgi?article=2510&amp;context=jtrp</a>	
2.3.6-25	FHWA/IN/J HRP-84/20	Indiana Highway Cost Allocation Study: Final Report; Kumares C. Sinha; Tien Fang Fwa; Essam Abdel-Aziz Sharaf; Ah Beng Tee; Harold L. Michael; Joint Transportation Research Program; <a href="http://ia600401.us.archive.org/20/items/indianahighwayco00sinh/indianahighwayco00sinh.pdf">http://ia600401.us.archive.org/20/items/indianahighwayco00sinh/indianahighwayco00sinh.pdf</a>	
<b>Kentucky</b>			
2.3.6-26	KTC-00-3	2000 Highway Cost Allocation Update; University of Kentucky, Kentucky Transportation Center; <a href="http://www.ktc.uky.edu/files/2012/06/KTC_00_03.pdf">http://www.ktc.uky.edu/files/2012/06/KTC_00_03.pdf</a>	
<b>Maryland</b>			
2.3.6-27	2009 MDTA	2009 Highway Cost Allocation Study for the Maryland	

<b>Methods and Cost Impacts of Bridge Serviceability</b>			
Reference No.	Document No.	Document Title and Link	Relevance to Study
	HCAS	Transportation Authority Toll Facilities; C. C. Fu; C. W. Schwartz; Erin Mahoney; University Of Maryland <a href="http://www.mdt.maryland.gov/Home/documents/Final_HCAS_FinalReport_052609.pdf">http://www.mdt.maryland.gov/Home/documents/Final_HCAS_FinalReport_052609.pdf</a>	
<b>Minnesota</b>			
2.3.6-28	MN/RC 2012-14	2012 Highway Cost Allocation and Determination of Heavy Freight Truck Permit Fees; Gupta, Diwakar; University of Minnesota <a href="http://www.lrrb.org/media/reports/201214.pdf">http://www.lrrb.org/media/reports/201214.pdf</a>	
2.3.6-29	1990 MN HCAS	1990 Results of the Minnesota Highway User Cost Allocation Study; Cambridge Systematics, SYDEC, The Urban Institute, Jack Faucett Associates <a href="http://www.dot.state.mn.us/research/pdf/1990-00.pdf">http://www.dot.state.mn.us/research/pdf/1990-00.pdf</a>	
<b>Nevada</b>			
2.3.6-30	2009 NV HCAS	2009 Nevada Highway Cost Allocation Study; Battelle; P Balducci; J Stowers; R Mingo; H Cohen; H Wolff; <a href="http://www.nevadadot.com/uploadedFiles/NDOT/About_NDOT/NDOT_Divisions/Planning/Performance_Analysis/Balducci%20Nevada%20DOT%20HCAS%20Compilation%20Report%20Jul%202030.pdf">http://www.nevadadot.com/uploadedFiles/NDOT/About_NDOT/NDOT_Divisions/Planning/Performance_Analysis/Balducci%20Nevada%20DOT%20HCAS%20Compilation%20Report%20Jul%202030.pdf</a>	
<b>New Jersey</b>			
2.3.6-31	FHWA-NJ- 2001-030	Infrastructure Costs Attributable to Commercial Vehicles; Dr. Boilé, Maria; Ozbay, Kaan; Narayanan, Preethi , Rutgers University, Center for Advanced Infrastructure & Transportation <a href="http://cait.rutgers.edu/files/FHWA-NJ-2001-030.pdf">http://cait.rutgers.edu/files/FHWA-NJ-2001-030.pdf</a>	
<b>New York</b>			
2.3.6-32		Effect of Overweight Vehicles on I-88 Bridges, Task 2.a &b Report – Draft for Part 1, March 2013; Graziano Fiorillo, Michel Ghosn; City College of New York	Cost Allocation
	<p>The object of this report is to describe a procedure that quantifies the effect to bridges caused by overweight trucks. The methodology is implemented on a representative sample of twenty three bridges along the I-88 corridor between Binghamton and Schenectady in New York State. The procedure is divided into three phases. In the first phase, the WIM data file which is assumed to be representative of the entire corridor is analyzed</p> <p>In the second phase, the maximum moment response of each vehicle contained in the WIM file is obtained for each bridge by sending each truck through the appropriate influence line. Finally, each truck’s response is used to estimate the effect caused by each truck.</p> <p>The cost analysis is executed for two types of effects: 1) Overstress effect and 2) fatigue effect. The overstress cost analysis follows the classical FHWA cost allocation model. The fatigue cost analysis follows the AASHTO LRFDF fatigue analysis method.</p>		

<b>Methods and Cost Impacts of Bridge Serviceability</b>			
Reference No.	Document No.	Document Title and Link	Relevance to Study
		<p>The cost model presented in this report is still preliminary pending the updating of the bridge design methodology that is taking place based on input from the TWG. Furthermore, the unit cost data for the steel and concrete are based on the unit costs obtained from the RS Means Heavy Construction Costs Database.</p> <p><i>As indicated above this bridge cost allocation study was conducted on 23 of the 40± bridges located on the I-88 corridor between Schoharie and Binghamton, NY. As indicated the Federal Incremental Method of cost allocation was used with some modifications.</i></p>	
<b>Ohio</b>			
2.3.6-33	2009 Ohio HCAS	Impacts of Permitted Trucking on Ohio's Transportation System and Economy; Director James G. Beasley, P.E., P.S. <a href="http://www.dot.state.oh.us/Divisions/Legislative/Documents/ImpactsofPermittedTrucking-Web.pdf">http://www.dot.state.oh.us/Divisions/Legislative/Documents/ImpactsofPermittedTrucking-Web.pdf</a>	
<b>Oregon</b>			
2.3.6-34	2011 Oregon HCAS	2011 Oregon Highway Cost Allocation Study <a href="http://www.oregon.gov/DAS/OEA/docs/highwaycost/2011report.pdf">http://www.oregon.gov/DAS/OEA/docs/highwaycost/2011report.pdf</a>	
<b>Tennessee</b>			
2.3.6-35	2009 TN HCAS	Highway Cost Allocation for Tennessee Final Report; 2009; Garcia, Alberto; Huang, Baoshan; Dai, Yuanshun; Dong, Qiao; Celso, Jonathan.  <a href="#">Document available upon request from TNDOT</a>	
<b>Texas</b>			
2.3.6-36	0-1810-1	A Framework for the Texas Highway Cost Allocation Study; Luskin, David M.; Garcia-Diaz, Alberto; Lee, DongJu; Zhang, Zhanmin; Walton, C. Michael; University of Texas; Texas A&M University <a href="http://www.utexas.edu/research/ctr/pdf_reports/1810_1.pdf">http://www.utexas.edu/research/ctr/pdf_reports/1810_1.pdf</a>	
2.3.6-37	FHWA/TX-02-1810-2	Texas Highway Cost Allocation Study; Luskin, David M.; Garcia-Diaz, Alberto; Zhang, Zhanmin; Walton, C. Michael; University of Texas; Texas A&M University <a href="http://www.utexas.edu/research/ctr/pdf_reports/1810_2.pdf">http://www.utexas.edu/research/ctr/pdf_reports/1810_2.pdf</a>	
<b>Vermont</b>			
2.3.6-38	1993 VT HCAS	1993 Vermont Highway Cost Allocation Study; SYDEC, Inc. <a href="http://www.ccrpevt.org/library/freight/highway_cost_allocation_study_19930223.pdf">http://www.ccrpevt.org/library/freight/highway_cost_allocation_study_19930223.pdf</a>	
2.3.6-39	VT_Pilot_2012	Vermont Pilot Program Report – a Truck Size & Weight Study, FHWA Office of Freight Management and Operations, 2012 <a href="http://ops.fhwa.dot.gov/freight/sw/reports/vt_pilot_2012/">http://ops.fhwa.dot.gov/freight/sw/reports/vt_pilot_2012/</a>	Truck Size & weight, HCAS, Fatigue

<b>Methods and Cost Impacts of Bridge Serviceability</b>			
Reference No.	Document No.	Document Title and Link	Relevance to Study
	<p><b>Executive Summary</b>                      Following the enactment of Public Law 111-117 (P.L. 111-117), Vermont raised truck size and weight limits on its Interstate highways for a 1-year period beginning December 16, 2009. Several heavier truck configurations that were previously limited to Vermont State highways, including a 6-axle 99,000-pound gross vehicle weight (GVW) truck, were allowed on the Interstate System during that period. As required by P.L. 111-117, the U.S. Department of Transportation (DOT) conducted a study to examine the effects of the heavier trucks on Interstate highways in Vermont during the Pilot period.</p> <p><b>Approach</b>                      While the study made the most of available models and data, a 1-year time period is simply insufficient to make any meaningful conclusions relative to the full consequences of a permanent change in vehicle weight restrictions in Vermont, or elsewhere. The pavement and bridge conclusions are based on truck volumes applied to deterministic models rather than observed damage. Pavement and bridge models are well advanced and capable of reliably predicting infrastructure impacts, while empirical measurement of infrastructure effects would require many years of empirical observation. The truck volumes applied to these models, as noted in the Commerce section of this report, reflect temporary changes and may or may not indicate how truck volumes and weights would change if the Pilot were permanent.</p> <p><b>Findings:</b>                      Bridges – Study results indicate that the Pilot Program had a negligible impact on Interstate bridges in Vermont. All of the analyzed bridges provided adequate capacity to safely support the Pilot loads. However, secondary members of two existing bridges will need strengthening if Pilot loads are allowed in the future. Vermont has typically designed its bridges to higher load standards than national specifications require. As a result, the superstructure components of both existing bridges and future designs that meet current national bridge design standards will have no problem supporting the Pilot loads.                      Bridge decks and deck wearing surfaces may be affected by heavier loads, but the costs to address these impacts are likely to be small in comparison to overall State highway expenditures. Other bridge components such as deck joints, bearings, piers, and abutments also may be affected, but these impacts cannot be quantified with currently available analytical tools. Long-term infrastructure costs will likely be less than for other States, especially given the relatively small truck volumes on those bridges.</p>		
<b>Washington DC</b>			
2.3.6-40	DDOT TSW 2010	District Wide Truck Size & Weight Study, Wilbur Smith Associates (CDM Smith & KS Engineers) 2010 Available upon request from CDM Smith	HCAS
<b>Wisconsin</b>			
2.3.6-41	WisDOT 0092-10-21 CFIRE 03-17	Aligning Oversize/Overweight (OSOW) Fees with Agency Costs: Critical Issues; Teresa Adams, Ph.D., Ernie Perry, Ph.D., Andrew Schwarts, Bob Gollnik, Myungook Kang, Jason Bittner and Steven Wagner; 2013	HCAS, OSOW Truck Study
<i>This document attempts to address a number of issues regarding OSOW trucks in Wisconsin. Of relevance to the 2013 CTSW is the attempt to allocate bridge cost to vehicles using the load based allocator – ESAL miles. This is one of the few states that have deviated from the Federal Cost</i>			

<b>Methods and Cost Impacts of Bridge Serviceability</b>			
Reference No.	Document No.	Document Title and Link	Relevance to Study
<i>Allocation method as outlined in this document.</i>			
<b>Australia</b>			
2.3.6-42		Third Heavy Vehicle Road Pricing Determination Technical Report, October 2005, Prepared by the National Transport Commission (NTC)	
<p>The paper provided details of the NTC’s calculation of heavy vehicles’ share of road costs, used in preparing recommendations for a Third Heavy Vehicle Road Pricing Determination, to be implemented in 2006.</p> <p><i>It should be noted that the Australian Bureau of Statistics is responsible for gathering both roadway cost data as well as vehicle usage data across states and territories and combining them in a uniform nationwide statistical database on an annual basis. This provides a common data bank with which to conduct cost allocation studies on a national basis.</i></p>			
<b>Europe</b>			
2.3.6-43	FP6-2005-TREN-4	Cost Allocation for Transportation Infrastructure (CATRIN) - Cost Allocation Practices in the European Transport Infrastructure Sector; 2008; European Transport Sector <a href="http://www.transport-research.info/Upload/Documents/201210/20121031_161818_54329_Catrin_D1_140308-final.pdf">http://www.transport-research.info/Upload/Documents/201210/20121031_161818_54329_Catrin_D1_140308-final.pdf</a>	
<p><i>The CATRIN project aims to collect cost allocations from 15 European Union countries including the UK, Sweden, Germany, Switzerland, the Netherlands, The Dutch, Hungary, Poland, Greece, Turkey and more. The document does not aggregate the costs across the countries, but does provide several charts and tables summarizing the various methods.</i></p>			
2.3.6-44		Guidelines for a Study of Highway Cost Allocation, Mudge, Kulash, Ewing; Natural Resources and Commerce Division of the Congressional Budget Office, 1979	HCAS Methodology
<p>This 1979 document provides some recommendations for future cost allocations as related to bridges. It goes on to recommend separating out certain bridge components such as bridge decks and metal; fatigue and allocating costs by a different allocator than if part of the whole. It is of interest that it was recommended that different “workable” methods be used for more equitable allocation of costs and for the most part these recommendations went largely ignored and perhaps lost in the large volume of cost allocations conducted to date.</p>			
2.3.6-45	NCHRP SYN 378	NCHRP Synthesis 378: State Highway Cost Allocation Studies; A Synthesis of Highway Practice ; CONSULTANTS: Patrick Balducci, Battelle Memorial Institute, Joseph Stowers, Sydec, Inc.; 2008 <a href="http://onlinepubs.trb.org/onlinepubs/nchrp/nchrp_syn_378.pdf">http://onlinepubs.trb.org/onlinepubs/nchrp/nchrp_syn_378.pdf</a>	HCAS Historic Summary and Methods
<p><i>This document provides a history of cost allocation studies and a compilation of methods used by various states. In that sense it is similar to the EU CATRIN document.</i></p>			
2.3.6-46		HCAS Bridge Analysis, (1997)	HCAS

<b>Methods and Cost Impacts of Bridge Serviceability</b>			
Reference No.	Document No.	Document Title and Link	Relevance to Study
		-Guidelines for Conducting a State Highway Cost Allocation Study Using the State HCAS Tool, 2000 -Documentation for Using the State HCAS Tool, 2000 Provided by the FHWA Office of Transportation Policy Studies Main investigator: James March and a team of consultants managed by Battelle Memorial Institute consisting of Roger Mingo, Joe Stowers, Harry Cohen, Holly Wolff, Dan Haling & Tom Foody. <a href="http://www.fhwa.dot.gov/policy/hcas/final/index.htm">http://www.fhwa.dot.gov/policy/hcas/final/index.htm</a>	
<p><i>The 1997 HCAS Method outlines a uniform method to conduct state cost allocations. The bridge portion of the report attempts to standardize and refine the “incremental” method developed in 70’s and 80’s. The final report was published in 2000. The method provides a series of interconnecting spreadsheets containing truck load spectra, WIM data, state cost data etc. to aid state conducting these studies.</i></p>			
2.3.6-47	NCHRP Rpt 495	NCHRP Report 495: Effect of Truck Weight on Bridge Network Costs; Gongkang Fu; Jihang Feng; Waseem Dekelbab; Center For Advanced Bridge Engineering, Wayne State University; Fred Moses; University Of Pittsburgh; Harry Cohen; Dennis Mertz; University Of Delaware; Paul Thompson (including the Software Module CARRIS 1.0, a series of interconnecting spreadsheet using WinBasic macros) <a href="http://onlinepubs.trb.org/onlinepubs/nchrp/nchrp_rpt_495.pdf">http://onlinepubs.trb.org/onlinepubs/nchrp/nchrp_rpt_495.pdf</a>	HCAS Methodology for Bridges
<p><i>NCHRP Report 495 has been the commonly used method in the US for state transportation agencies and jurisdictions to conduct cost allocation studies in a modified format for their entire network of bridges or for a specific trucking corridor. The method was a refinement of the Federal “Incremental” Highway Cost Allocation method of 1997. The full report provides appendices, look up tables, step by step procedures and examples for two states. In addition it includes a software CD for the CARRIS, excel based interconnecting spreadsheets. The method compiles costs based on four cost categories – Steel Fatigue Retrofits, Reinforced Concrete Deck Fatigue, Deficiency due to existing bridge overstress and Deficiency due to new bridge overstress. The method investigates the load impact or effects of increasingly heavier trucks on the cost of posting, retrofitting or replacing a vulnerable bridge. It then extrapolates those costs to similar bridges on the network. The method is capable of investigating the effects of altering the mix of the trucks (modal shift) on the same cost categories listed above.</i></p> <p><i>States have used this methodology in part or as whole to conduct bridge cost allocation studies. To our knowledge, a nationwide bridge study using this methodology has not occurred to date. As the name indicates, this is a “state” tool.</i></p> <p><i>The fatigue methodology and formulations presented in this document will be included in one of the sub task studies on the fatigue related effects on reinforced concrete decks.</i></p>			
2.3.6-48	SWUTC/10/4 76660-00064-1	A Road Pricing Methodology for Infrastructure Cost Recovery; Southwest University Transportation Center; Conway, Alison J.; Walton, C. Michael ; 2010 <a href="http://d2dtl5nnlpr0r.cloudfront.net/swutc.tamu.edu/publications/technicalreports/476660-00064-1.pdf">http://d2dtl5nnlpr0r.cloudfront.net/swutc.tamu.edu/publications/technicalreports/476660-00064-1.pdf</a>	HCAS Method

<b>Methods and Cost Impacts of Bridge Serviceability</b>			
Reference No.	Document No.	Document Title and Link	Relevance to Study
		<p><b>Abstract:</b> The purpose of this research is to provide a theoretical framework for future commercial vehicle user-charging using real-time vehicle weight and configuration information collected using weigh-in-motion (WIM) systems. This work provides an extensive review of both mechanisms and technologies employed for commercial and passenger vehicle user-charging worldwide. Existing commercial vehicle-user charging structures use only broad vehicle classifications to distinguish between vehicles for the pricing of user-fees. The methodology proposed in this study employs highway cost allocation methods for development of an “Axle-Load” toll structure. A theoretical case study, based on information from Texas State Highway 130, is performed to explore the equity improvements that could be achieved through implementation of this proposed structure. Some sensitivity analysis is also performed to examine the potential revenue impacts due to uncertainties in different data inputs under existing and proposed structures.</p>	
2.3.6-49		<p>Cost Allocation By Uniform Traffic Removal Theoretical Discussion And Example Highway Cost Applications; 1992 Chris Hendrickson Department of Civil Engineering, Carnegie-Mellon University, and Kane, Anthony; Pergammon Press, UK Office of Program and Policy Planning, Federal Highway Administration, Washington. DC 20590. U.S.A.</p>	HCAS Method
		<p><b>Abstract:</b> The paper proposes 4 methods for equitable roadway cost allocations: (a) allocated costs should be based on full cost recovery, (b) allocated costs must be non-negative for any traveler group, (c) cost allocations should be additive, and (d) cost allocations should be consistent where equivalency factors among traffic categories exist. For cases with well-behaved cost functions, the uniform traffic removal technique discussed here uniquely satisfies these four properties and should be used whenever the four allocation properties are desired. Example applications as well as cases in which cost functions are not well behaved are discussed</p>	
2.3.6-50		<p>Highway Cost Allocation Methodologies; Alemayehi Ambo, F.R. Wilson and A.M. Sevens; Transportation Group, University of New Brunswick, Fredericton, N.B. Canada; January 1991</p>	HCAS
		<p><b>Abstract:</b> Four methodologies of life-cycle highway cost allocation were examined using the province of New Brunswick, Canada as a case study. The first two methodologies were reported by Wong and Markov. The third methodology was suggested by Rilett et al. The fourth methodology was introduced as part of a research project. It was in line with the procedures practiced in public accounts for the construction and maintenance of roads on a continuing basis. The four methodologies were tested using the same data base pertaining to vehicle types; traffic measures (independent vehicle, passenger car equivalents, and equivalent standard axle loads); and costs of construction, maintenance, and rehabilitation. These data were applicable to a major two-lane highway in the study area. Six sites were selected for the case study. An analysis period of 60 years, three traffic growth scenarios, three pavement design periods were considered. Eleven types of vehicles comprising passenger cars, light trucks and vans, trucks, buses and recreational vehicles were used in the analysis. The assessment of the methodologies resulted in the recommendation of and suggestions for the costing of highways. <i>This was the only document related to Bridge Cost Allocation study in Canada. Studies referenced at the Transport Association of Canada web site refer to US studies. We will continue to search for any relevant provincial or national Canadian Studies.</i></p>	



<b>Methods and Cost Impacts of Bridge Serviceability</b>			
Reference No.	Document No.	Document Title and Link	Relevance to Study
2.3.6-51	Freight Facts and Figures 2012	Office of Freight Management and Operations- Freight Facts and Figures 2012; Office of Freight Management; <a href="http://www.freight.dot.gov">http://www.freight.dot.gov</a>	Freight
<p><i>Freight Facts and Figures 2012</i> is a snapshot of the volume and value of freight flows in the United States, the physical network over which freight moves, the economic conditions that generate freight movements, the industry that carries freight, and the safety, energy, and environmental implications of freight transportation. This snapshot helps decision makers, planners, and the public understand the magnitude and importance of freight transportation to the economy.</p> <p><i>This report provides information on freight volume and movement between modes of transportation. It is referenced by the team to better understand modal shift data and issues.</i></p>			
2.3.6-52	FHWA/IN/JT RP-2004/12	Quality Control Procedures for Weigh-in-Motion Data; Andrew P Nichols; <i>Marshall University</i> ; Darcy M. Bullock, Purdue University; <a href="http://docs.lib.purdue.edu/cgi/viewcontent.cgi?article=1647&amp;context=jtrp">http://docs.lib.purdue.edu/cgi/viewcontent.cgi?article=1647&amp;context=jtrp</a>	WIM Data
<p><b>Abstract:</b> For the past two decades, weigh-in-motion (WIM) sensors have been used in the United States to collect vehicle weight data for designing pavements and monitoring their performance. The use of these sensors is now being expanded for enforcement purposes to provide virtual weigh stations for screening vehicles in traffic streams for overweight violations. A study found that static weigh stations in Indiana were effective for identifying safety violations, but ineffective for identifying overweight vehicles. It was also determined that the alternative approach to identifying overweight vehicles using virtual weigh stations requires a high level of WIM data accuracy and reliability that can only be attained with a rigorous quality control program. Accurate WIM data is also essential to the success of the Long-term Pavement Performance project and the development of new pavement design methods. This report proposes a quality control program that addresses vehicle classification, speed, axle spacing, and weight accuracy by identifying robust metrics that can be continuously monitored using statistical process control procedures that differentiate between sensor noise and events that require intervention. The speed and axle spacing accuracy is assessed by examining the drive tandem axle spacing of the population of Class 9 vehicles. The weight accuracy is assessed by examining the left-right steer axle residual weight of the population of Class 9 vehicles. Data mining of these metrics revealed variations in the data caused by incorrect calibration, sensor failure, temperature, and precipitation. The accuracy metrics could be implemented in a performance-based specification for WIM systems that is more feasible to enforce than the current specifications based on comparing static vehicle weights with dynamic vehicle weights measured by the WIM sensors. The quality control program can also be used by agencies to prioritize maintenance to more effectively allocate the limited funds available for sensor repair and calibration. This research provides a tool that agencies can use to obtain and sustain higher quality WIM data.</p> <p><i>This report provides detailed information on WIM sensors, how WIM data is collected, data mining and WIM data quality issues. It is essential in understanding the WIM data that will be provided by other task leads, quality and reliability issues.</i></p>			
2.3.6-53	NCHRP RPT	Protocols for Collecting and Using Traffic Data in Bridge Design. B. Sivakumar; M. Ghosn; F. Moses; TranSystems	WIM Data

<b>Methods and Cost Impacts of Bridge Serviceability</b>			
<b>Reference No.</b>	<b>Document No.</b>	<b>Document Title and Link</b>	<b>Relevance to Study</b>
	683	Corporation, 2011. <a href="http://onlinepubs.trb.org/onlinepubs/nchrp/nchrp_rpt_683.pdf">http://onlinepubs.trb.org/onlinepubs/nchrp/nchrp_rpt_683.pdf</a>	Scrubbing
	<p>This report documents and presents the results of a study to develop a set of protocols and methodologies for using available recent truck traffic data to develop and calibrate live load models for LRFD bridge design. The HL-93, a combination of the HS20 truck and lane loads, was developed using 1975 truck data from the Ontario Ministry of Transportation to project a 75-year live-load occurrence. Because truck traffic volume and weight have increased and truck configurations have become more complex, the 1975 Ontario data do not represent present U.S traffic loadings. The goal of this project, therefore, was to develop a set of protocols and methodologies for using available recent truck traffic data collected at different US sites and recommend a step-by-step procedure that can be followed to obtain live load models for LRFD bridge design. The protocols are geared to address the collection, processing and use of national WIM data to develop and calibrate vehicular loads for LRFD superstructure design, fatigue design, deck design and design for overload permits. These protocols are appropriate for national use or data specific to a state or local jurisdiction where the truck weight regulations and/or traffic conditions may be significantly different from national standards. The study also gives practical examples of implementing these protocols with recent national WIM data drawn from states/sites around the country with different traffic exposures, load spectra, and truck configurations.</p>		
	<p>In addition, for documents referencing Methods and Impacts of Bridge Serviceability see “Reference No’s.”: 2.1.6-12; 2.1.6-16; 2.1.6-17; 2.1.6-18; 2.1.6-22</p>		

## CHAPTER 3 – BRIDGE DECK DETERIORATION, SERVICE LIFE AND PREVENTATIVE MAINTENANCE

This sub-study area was originally conceived as two independent studies, ‘Bridge Deck Deterioration Mechanisms’ and ‘Bridge Deck Preservation and Maintenance’. It was soon realized that these topics are intimately related and integrated in terms of agency program implementation. Accordingly they have been combined in this report.

### **3.1 A Survey of Analysis Methods and Synthesis of the State of Practice in Modeling Bridge Deck Impacts**

#### ***3.1.1 Bridge Deck Deterioration Model***

Analysis and design methods of reinforced concrete bridge decks are based on the AASHTO LRFD Bridge Design Specifications, 2011, 6th Edition. Reinforced concrete bridge decks behave in a complex manner, especially at the end of the serviceable deck life, however the design of decks is simply based on ultimate flexural strength. In order to understand the assumptions and limitations the bridge team explored other existing models that can define, measure and predict bridge deck damage. The desk scan included studies related to bridge deck deterioration mechanisms either based on 1) chloride contamination/freeze thaw action; or 2) mechanical-dynamic and repetitive loading. Studies and experiments that involved both deterioration mechanisms were limited in scope and only provided qualitative descriptions of the mechanisms and no quantifying metrics on deck damage.

Reports by Williamson and Weyers, et al., (Virginia DOT) 2008 and N. Hu and Syed, et al, (Michigan DOT) 2013 used a probabilistic framework based on chloride contamination of the reinforcement bars through a pre-existing network of micro-cracks and the eventual re-cracking and deterioration of the bridge deck due to freeze-thaw action. Y. Tanaka et al, 2009 (Japan Public Works Research Institute PWRI), Takashi et al (PWRI) in two separate reports studied the effects of truck axle loads (both static and dynamic) on bridge decks and the propagation of cracks from a microscopic scale to general deck failure in cold weather climates. The primary cause of failure in these studies was considered to be repetitive axle loading. In a Nebraska Department of Roads (NDOR) study, G. Morcous, 2011, used a data driven approach (using bridge deck ratings from inspection data) to predict when bridge (deck) ratings were likely to fall from a given condition state to a lower level. Further refinements were implemented by incorporating ADTT and cold/wet climatic data. It also demonstrated how the rate of deterioration of bridge decks increased non-linearly as the truck GVW increased. A general trend among current efforts is to develop predictive models following the data driven approach.

- Finding: These studies acknowledged the need to study the long term combined effects of axle loads and wet/cold climates. And metrics need to be established to quantify damage based on both mechanisms. The search for related studies revealed there is very little research in this area.

The search for deterioration models also considered service limit states as described by the Auburn University Study, Cost/Benefits of Employing Thicker Bridge Decks (Ramey, et al., 2000). Alabama bridge decks were cracking prematurely under regular truck axle loads and were found to be 1” to 1.5” thinner than comparable bridge decks in most other states. A California case study (as chronicled in NCHRP Report 495, 2003) compared two parallel alignment interstate bridge decks in Alameda County. One deck allowed only passenger cars and light trucks, while the other bridge deck, although slightly thicker (1”), allowed all truck traffic over a 37 year period. The thicker bridge deck with heavy truck traffic exhibited more surface damage even after a rehabilitation project at the end of the 37 years than the thinner bridge deck with no major rehabilitation.

S. Matsui (1991), P. Perdikaris (1993), and Tanaka (2003) conducted studies on the fatigue mechanisms in concrete decks combined with the effects of de-icing salts. The life cycle of bridge decks from construction to deck fracturing and failure were established and arching behavior of fractured bridge decks was investigated. It was further established that de-icing salts (chloride contamination) greatly accelerated the deterioration process.

- Finding: The clear indication is that chloride contamination accelerates bridge deck deterioration. But this is only observed at the mid- to near the end life cycle of the bridge, mainly due to the period of time it takes for the chlorides to permeate through the bridge deck and form oxidation or rust products around the reinforcement bars, which in turn causes delamination of the surrounding concrete.
- Finding: The desk scan revealed that there is no commonly accepted metric to measure the degree of bridge deck deterioration. However, some studies attempted to measure the density of surface defects while others measured the degree of internal cracking or fracturing. This may be due to the number of variables involved in developing such a model. These variables include concrete mix, construction methods (support/shoring and curing), deck thickness, beam spacing and actual truck axle loadings.

An Ohio DOT study by Ganapuram et al, 2012 looked at 12 bridges in Ohio District 3 and compared concrete slab bridges to stringer supported bridges. An Indiana DOT study by Frosch et al, 2010 studied early onset deck cracking with the objective of developing more effective design and repair methods to extend deck life. Another Indiana DOT study by Yang et al., 2004 investigated the interaction between micro-cracking and reduced concrete durability with the purpose of: assessing cumulative damage; finding common parameters among pavements that could quantify overall damage; and testing/calibrating non-destructive technologies. This study was conducted on concrete pavements and not bridge decks; but it may still provide insight into bridge deck deterioration mechanisms. None of these studies, while informative were conducted with the goal of establishing a uniform metric for measuring or quantifying bridge deck damage.

### ***3.1.2 State DOT Policies on Repair, Replacement and Preservation***

As indicated above, many states have deployed an integrated asset management system which combines (bridge) inspection data (condition reports) with the availability of their maintenance forces (crews, equipment and budget) and tries to target the repair and rehabilitation of bridges with the most critical needs. The scope of the activity determines whether the repairs are done with in-house maintenance crews (for such activities as patching and crack sealing of the decks) or if they become part of a capital program involving design and specialty contractors (such as deck replacement or a programmatic deck joint replacement). How these decisions are made depends on the DOT capabilities as well as their policies.

The desk scan of DOT web sites for maintenance and preservation policies found several DOT web sites that either had published manuals available with PDF downloads or had web pages/portals that listed their policies and practices for bridge deck preservation and maintenance. These included California (Caltrans Highway Maintenance Manual, Volume 1, 2006), Indiana (IDOT Highway Maintenance Manual, Chapter 72, Bridge Rehabilitation 2013), Michigan (Capital Scheduled Maintenance, Bridge Manual, 2010) and Ohio (ODOT, Web site only). The team also found secure portals that required credentials and were tied in with their bridge inspection software. As such we were limited to what could be gleaned from the various agencies.

Bridge Deck Asset Management TRB and NCHRP reports: The desk scan also addressed the national effort to standardize the data and reporting practices. On the bridge inspection side (NBIS), MAP-21 requires that FHWA start collecting element level bridge data for the NBI on the NHS within two years, and to conduct a study of benefits and costs associated with extending this requirement to non-NHS bridges. Many states are now using Element Level Inspection (ELI) in concert with a bridge management system (BMS). NCHRP Report 668, G. Hearn et al, 2010 investigated the use of Bridge (Asset) Management Systems (BMS) and setting up a national standard for collecting, reporting and storing information on bridge maintenance actions. The underlying reason for employing these systems is to provide a framework for developing a data-driven predictive bridge (deck) model that may alert agencies when a specific action is recommended to prolong and preserve bridge (deck) life. In other words, a bridge deck deterioration model would be built into the asset management system.

## **3.2 Data needs and an evaluation and critique of available data sources for bridge decks**

### ***3.2.1 Comparison of State Unit Cost Data***

The following DOT web sites were found to readily provide public access information on bridge projects and provide unit cost data: Alabama, Arkansas, California, Colorado, Connecticut, Delaware, Florida, Georgia, Indiana, Louisiana, Missouri, Nebraska, New York, Ohio, Virginia, Pennsylvania, Tennessee, Washington, DC, and Wisconsin.

This unit cost data was valuable in that it generally consisted of real costs reported by contractors, however the reported cost categories varied widely in their description of what was

included and therefore the range of costs for similar work items had considerable variation. Therefore the need for a national bridge asset management standard becomes inherently obvious. There must be an agreement on which cost elements to include in the quoted costs (such as design engineering, mobilization / de-mobilization, Work Zone Traffic Control (WZTC), Construction Inspection (CI), demolition and removal).

In order to augment some of our findings regarding the bridge deck deterioration mechanism the bridge team conducted a qualitative anecdotal survey (interview) of two agency bridge owners/managers. The bridge team contacted the Indiana DOT and the New York Bridge Authority in order to conduct informal interviews on the condition of their bridge decks on routes that routinely allow heavier (permitted) trucks, heavier than the current Federal weight limits. The information gained from these agencies confirmed our understanding of bridge deck deterioration mechanisms and the critical effects of heavy trucks and axle loadings.

NCHRP Project 14-15, led by principal investigator G. Hearn (Univ. Of Colorado), developed a framework that could be a model for collection of bridge inspection data to tie into state and national bridge management databases. States are beginning to develop bridge management systems based on element level inspection data, PONTIS and life cycle cost analysis. Georgia, North Carolina and New York are examples of states that are in various phases of development of such programs. New York DOT's Bridge Data Information System (BDIS) will be incorporated into an integrated total infrastructure asset management system that will include bridges, office buildings, parking facilities, rest areas, pavement, sign structures, high mast lights, cell towers, retaining walls, culverts and perhaps tunnel structures.

### **3.3 An assessment of the current state of the understanding of the impact and needs for future research, data collection and evaluation**

- There is a lack of research combining the effects of the primary long term bridge deck deterioration mechanisms; the repetitive effect of dynamic axle loads and climatic effects (i.e., chloride contamination).
- There is no accepted uniform metric to quantify the degree of deck deterioration and to correlate it with inspection ratings. However, condition states for element level inspections represent an effort toward this goal, one that will likely be incorporated into the FHWA's greater goal of establishing a long term data driven transportation infrastructure program management system.
- There is a lack of consistency in data (cost) format and reporting methods between agencies, partly due to the lack of a uniform reporting standard. This is also partly due to different rehabilitation and preservation practices between the states. It's to a large degree a product of the policies that drive the states' capital programs. For instance, one state might include proactive minor repairs in their capital cost tabulation that would be considered as preventive maintenance by other states, the costs for which would be buried in the accounting for a general highway department. Another factor contributing to

the lack of consistency in reporting bridge costs is the degree to which a given agency is proactive or on the other hand reactive with respect to bridge deterioration. At a national level FHWA's FMIS program collects and summarizes bridge related costs for each of the states. However, these are project costs and may include approach highway work. Due to the lack of detail in the FMIS data, it is difficult to segregate the bridge specific component of these costs. Also, many of these projects and/or parts of these projects would not be a result of load induced factors. There is an effort underway to establish a framework for building a national bridge database with standardized reporting methods. In addition many states have implemented or about to implement asset management systems which may include life cycle analyses to prolong the intended serviceable life of bridge decks. The BMS will help these states to comply with the overall national effort in developing the bridge (deck) database and all agencies will potentially benefit from it.

- Implied in developing this database and the BMS is that it may include or lead to a predictive data driven model on bridge deck deterioration.

#### **3.4 Past studies with past prospective and retrospective estimates in each category of effect**

- Past CTSW studies did not include sections specifically dedicated to bridge decks. This was a new and unique area of study for the 2014 CTSW Study. It represents one of the highest cost bridge elements (to state DOT agencies) and one of the most visible elements to the traveling public. Past CTSW studies investigated the structural behavior of the bridge, as a whole, with respect to truck impacts.
- NCHRP Report 495 (2003) Effect of Truck Weight of Bridge Network Costs provided a method for State Agencies to study the cost impacts on their bridges. One of the cost elements in that study was the effect of trucks on reinforced concrete bridge deck fatigue. The report provided insight and references for the bridge deck behavior and deterioration mechanism, however the limited time and scope of this project as well as its national scale, did not allow for a direct application of that very complex method with its numerous variable parameters to this study.
- There is what appears to be a flaw in using reinforced concrete fatigue life as a metric for estimating bridge deck health. The method uses AASHTO fatigue trucks as a baseline and typically bridge deck fatigue life ranges exceed hundreds of years. The current accepted average bridge deck serviceable life is 25 to 55 years in most regions. In this regard, there needs to be a calibration of the fatigue life estimation to actual bridge deck service life.

### 3.5 List of References

<b>Modeling and Discussing Bridge Deck Impacts due to Overweight Trucks and Environmental Effects</b>			
Reference No.	Document No.	Document Title and Link	Relevance to Study
<p><i>The topic of bridge asset management was included to hi-light a series of topics germane to state policies toward the maintenance and preservation of bridges. Key questions addressed include: First, what are the tools that state agencies use (such as PONTIS and Bridge Management Systems) for asset management? Secondly what decision making process is used for preserving, retrofitting or replacing bridges? Thirdly what is included/excluded in their budgets? Ultimately we are interested in the bridge costs that the proposed future fleet of trucks will have on the nation's bridges.</i></p> <p><i>The link to the <b>FHWA Long Term Bridge Performance (LTBP)</b> web site and publications were included in this study. There is an apparent paradigm in thinking and philosophy that is occurring in light of the nation's aging bridges. In the past 100 years or so, bridges have been built with a planned life span of 75 years. What design standards do we use for trucks that have not yet been conceived and how will these bridges be designed and constructed to meet future needs for an extended life cycle? It's an interesting question, since we are attempting to address a similar issue with regard to bridges that are in service now. How will they perform under the load of a different set of vehicles?</i></p> <p><i>Another issue that has been raised with regard to bridge preservation and maintenance costs: as indicated by NCHRP Synthesis Report 397 each state has its own unique set of practices and cost factors that are tracked. How can this data be used to make comparisons between states that allow heavier vehicles vs. those that do not? Is it even possible to draw such conclusions? In a greater context can these costs be collected in a standardized way to conduct a national cost allocation study?</i></p> <p><i>References in this section were selected to address specific issues or were general informational topics relating to bridge decks. The first several reports refer to bridge deck durability, methods for preserving decks including different overlay methods and materials, design of orthotropic steel decks, non-destructive testing of reinforced concrete decks, and a few articles on causes of cracking in reinforced concrete decks whether they be caused by construction (early stripping of forms, improper curing, shrinkage), environment (temperature, rain, snow followed by application of de-icing salts) and/or load induced by vehicles and trucks. An effort is made to understand that initial cracking in bridge decks may not be necessarily caused just by vehicles and trucks, but by other means. However, the eventual development of cracks and other deterioration can be partially attributed to the traveling vehicles (i.e. load) on the bridge deck.</i></p> <p><i>An important reference for bridge decks is the <b>NCHRP Report 495, Effect of Truck Weights on Bridge Network Costs</b>. This report describes an approach for evaluating reinforced concrete bridge decks for crack propagation as it relates to cost allocations studies. However, a very detailed section is provided on describing the deck deterioration mechanism and ties the failure point of decks to the ultimate shear strength of the deck. (Based on independent studies conducted by Matsui et al at Osaka University Japan 1992 &amp; by Perdicaris at Case Western Reserve University 1993).</i></p>			
3.5-1		California Department of Transportation (2006). Highway Maintenance Manual, Volume 1 Chapter H. <a href="http://www.dot.ca.gov/hq/maint/manual/maintman.htm">http://www.dot.ca.gov/hq/maint/manual/maintman.htm</a>	Bridge Asset Management
This is a series of web based online highway maintenance manuals developed by Caltrans.			



<b>Modeling and Discussing Bridge Deck Impacts due to Overweight Trucks and Environmental Effects</b>			
Reference No.	Document No.	Document Title and Link	Relevance to Study
		Chapter H pertains to Bridge Maintenance and Repair Practices. Of particular interest was section H.08.0, which discouraged the use of asphaltic concrete overlay over concrete decks, which are commonly used elsewhere.	
3.5-2		Indiana Department of Transportation (2013). Highway Maintenance Manual, Chapter 72, Bridge Rehabilitation	Bridge Asset Management
		Chapter 72, sub section 3.01(02) describes typical department practices with respect to bridge deck rehabilitation. The department does not proscribe the use of asphaltic concrete overlay. The Department is actively researching use of various other repair and rehabilitation materials to prolong bridge decks. See research under “Implementation of Performance Based Bridge Deck Protective Systems”, Frosch, et al 2013.	
3.5-3	FHWA-HRT-08-004	History Lessons From the National Bridge Inventory; Analyzing data from the NBI can help predict how bridge decks will perform, Waseem Dekelbab, Adel Al-Wazeer, Bobby Harris, FHWA Turner Fairbanks – Public Roads – Vol. 71, No. 6 <a href="http://www.fhwa.dot.gov/publications/publicroads/08may/05.cfm">http://www.fhwa.dot.gov/publications/publicroads/08may/05.cfm</a>	Bridge Deck Deterioration Models
		<p>Researchers recently analyzed the numbers and data stored in the NBI. Their findings could offer insight and improve understanding of bridge performance based on 24 years of information compiled in the database. For example, information gained from this research will help answer the question, “How much longer is a bridge in a certain condition likely to stay in that condition before deteriorating further?”</p> <p><b>Deterioration Models for Bridge Decks</b></p> <p>Predicting performance is the main challenge in the life-cycle assessment and asset management of bridges. Performance of the bridge deck is a major maintenance and serviceability concern because the deck is the component most prone to problems that affect traffic and requires the most maintenance and replacement work. Loss of deck performance generally results from corrosion (caused by natural salinity or direct application of deicing agents), traffic loading and vibration, temperature fluctuations, and other factors. A modeling method based on medical “survivability” concept of “survival” function was developed.</p> <p><i>This article offers another bridge deterioration model based on NBI data. As with the other probabilistic models it is not yet able to predict behavior based on truck load-induced truck damage. Furthermore, it is a study in progress and no definitive methodology has been suggested.</i></p>	
3.5-4	FHWA-ICT-12-003	Superiority & Constructability of Fibrous Additives for Bridge Deck Overlays, Alhassan, Mohammad A, Ashur, Soleiman A, Indiana-Purdue University Fort Wayne; Illinois Center for Transportation <a href="https://apps.ict.illinois.edu/projects/getfile.asp?id=3054">https://apps.ict.illinois.edu/projects/getfile.asp?id=3054</a>	Bridge Deck, Durability, Life Cycle Analysis
		This project outlined critical issues essential for successful and durable overlay applications with minimal cracking and delamination. Various micro- and macro-fiber combinations were added to the fibrous overlay mixtures, resulting in 13 fibrous mix designs (nine LMC, two MSC, and two	

<b>Modeling and Discussing Bridge Deck Impacts due to Overweight Trucks and Environmental Effects</b>			
Reference No.	Document No.	Document Title and Link	Relevance to Study
		FAC). For further evaluation of the constructability of fibrous overlay—taking into consideration actual field conditions—demonstration bridges were selected and received fibrous overlays through actual IDOT contracts. Life-cycle cost analyses were also conducted to assess potential savings from incorporating fibrous additives within the concrete overlays. This research is pioneering in terms of using fibrous FAC overlay, which could be a potentially sustainable overlay system for preserving bridge decks with lower cost and minimized adverse environmental impact.	
3.5-5	FHWA-IF-12-027	Manual for Design, Construction, and Maintenance of Orthotropic Steel Deck Bridges; 2012, Conner, Robert, Fisher, John, et al. <a href="http://www.fhwa.dot.gov/bridge/pubs/if12027/if12027.pdf">http://www.fhwa.dot.gov/bridge/pubs/if12027/if12027.pdf</a>	Orthotropic Steel Decks
		This Manual covers the relevant issues related to orthotropic steel deck bridge engineering, including analysis, design, detailing, fabrication, testing, inspection, evaluation, and repair. It includes a discussion of some the various applications of orthotropic bridge construction to provide background with case study examples. It also provides basic criteria for the establishment of a cost-effective and serviceable orthotropic bridge cross section with detailing geometry that has been used on recent projects worldwide. The manual covers both the relevant information necessary for the engineering analysis of the orthotropic steel bridge and the requirements for complete design of orthotropic steel bridge superstructures. Additionally, design details such as materials, corrosion protection, minimum proportions, and connection geometry are addressed as well as basic fabrication, welding, and erection procedures. Portions of the manual also cover methods for maintaining and evaluating orthotropic bridges, including inspection and load rating. Wearing surfaces are also covered in depth. The culmination of all the information is demonstrated in two design examples.	
3.5-6	NCHRP SYN 425	Waterproofing Membranes for Concrete Bridge Decks; Prepared by Russell, Henry G. for AASHTO <a href="http://onlinepubs.trb.org/onlinepubs/nchrp/nchrp_syn_425.pdf">http://onlinepubs.trb.org/onlinepubs/nchrp/nchrp_syn_425.pdf</a>	Bridge Decks
		The objective of this synthesis is to update <i>NCHRP Synthesis of Highway Practice 220: Waterproofing Membranes for Concrete Bridge Decks</i> on the same topic published in 1995. This synthesis documents information on materials, specification requirements, design details, application methods, system performance, and costs of waterproofing membranes used on new and existing bridge decks since 1995. The synthesis focuses on North American practices with some information provided about systems used in Europe and Asia.	
3.5-7	FHWA/OH-2012/3	Quantification of Cracks in Concrete Bridge Decks in Ohio District 3; 2012; Sai Ganapuram, Michael Adams, Dr. Anil Patnaik; University of Akron <a href="http://www.dot.state.oh.us/Divisions/Planning/SPR/Research/reportsandplans/Reports/2012/Structures/134564_FR.pdf">http://www.dot.state.oh.us/Divisions/Planning/SPR/Research/reportsandplans/Reports/2012/Structures/134564_FR.pdf</a>	Bridge Decks, Cracks
		In this study, a quantitative measurement strategy was adopted by measuring the crack densities of twelve bridges in District 3. Two types of bridges were inspected: three structural slab bridge decks and nine stringer supported bridge decks. Crack densities were determined based on crack maps corresponding to the surveys for each bridge deck. The crack densities determined for the	

<b>Modeling and Discussing Bridge Deck Impacts due to Overweight Trucks and Environmental Effects</b>			
Reference No.	Document No.	Document Title and Link	Relevance to Study
		twelve bridge decks indicated that structural slab bridge decks have slightly higher shrinkage crack densities compared to the bridge decks constructed with stringer supports.	
3.5-8	SHRP2 S2-R06A-PR1	Nondestructive Testing to Identify Concrete Bridge Deck Deterioration; Rutgers University – Center for Advanced Infrastructure and Transportation; University of Texas at El Paso; Federal Institute for Materials Research and Testing, BAM Germany; Radar Systems International <a href="http://onlinepubs.trb.org/onlinepubs/shrp2/SHRP2_S2-R06A-RR-1.pdf">http://onlinepubs.trb.org/onlinepubs/shrp2/SHRP2_S2-R06A-RR-1.pdf</a>	Bridge Decks, Non-Destructive Testing (NDT)
		The ultimate goal of this research was to identify and describe the effective use of NDT technologies that can detect and characterize deterioration in bridge decks. To achieve this goal, the following four specific objectives needed to be accomplished: <ol style="list-style-type: none"> <li>1. Identifying and characterizing NDT technologies for the rapid condition assessment of concrete bridge decks;</li> <li>2. Validating the strengths and limitations of applicable NDT technologies from the perspectives of accuracy, precision, ease of use, speed, and cost;</li> <li>3. Recommending test procedures and protocols for the most effective application of the promising technologies; and</li> <li>4. Synthesizing the information regarding the recommended technologies needed in an electronic repository for practitioners</li> </ol>	
3.5-9	FHWA/IN/JT RP-2010/04	Control and Repair of Bridge Deck Cracking, Robert Frosch, Sergio Gutierrez, Jacob Hoffman; Purdue University; Indiana DOT; 2010 <a href="http://docs.lib.purdue.edu/jtrp/1125">http://docs.lib.purdue.edu/jtrp/1125</a>	Bridge Deck Cracking
		A large number of bridges across the state of Indiana had exhibited early age deck cracking. This presented a major threat to the lifespan of these bridges, as deck cracking often leads to corrosion of the reinforcing steel by creating a path for water and deicing salts to reach the steel. Therefore, the need to develop design and construction guidelines to control deck cracking in newly constructed bridges was recognized. In addition, a method to repair deck cracks must be developed to prevent corrosion of the reinforcement in bridges already in service. The objective of this research was to develop effective design, construction, and repair methods for the control of bridge deck cracking	
3.5-10	FHWA/IN/JT RP-2013/12	Implementation of Performance Based Bridge Deck Protective Systems, R.J. Frosch, M.E. Kreger, and B. Strandquist; Purdue University, Indiana DOT; 2013 <a href="http://docs.lib.purdue.edu/jtrp/1533">http://docs.lib.purdue.edu/jtrp/1533</a>	Bridge Decks
		When considering the durability of a bridge, the concrete deck is often the most vulnerable component and can be the limiting factor affecting service life. To enhance the durability of both new and existing bridge decks, a protective system is often provided to prevent or delay the ingress of chlorides and moisture to the reinforcing steel. In the state of Indiana, this protective system typically comes in the form of a concrete overlay or a thin polymer overlay. Another protective system widely used in the United States and in many countries internationally consists	

<b>Modeling and Discussing Bridge Deck Impacts due to Overweight Trucks and Environmental Effects</b>			
<b>Reference No.</b>	<b>Document No.</b>	<b>Document Title and Link</b>	<b>Relevance to Study</b>
		<p>of a waterproofing membrane overlaid with asphaltic concrete. Due to a history of poor performance in the 1970's and the 1980's, a moratorium has been placed on the installation of waterproofing membranes in Indiana. This study reevaluates the state-of-the-practice of bridge deck protection in Indiana with the goal of enhancing the Indiana Department of Transportation's toolbox of bridge deck protective systems. Consideration was given to the state-of-the-art and state-of-the-practice in bridge deck protective systems used by other state transportation agencies as well as by international transportation agencies. Research focused on the practice of installing waterproofing membranes and the latest technologies being used. Based on the information gathered, various protective systems were evaluated, and recommendations are provided on the selection of the most appropriate systems for various bridge conditions. Furthermore, a recommendation is provided to remove the moratorium on membrane systems so that the benefits of this system can be more fully explored and realized.</p>	
3.5-11	FHWA/IN/JT RP-2004/10	<p>Interaction Between Micro-Cracking, Cracking, and Reduced Durability of Concrete: Developing Methods for Quantifying the Influence of Cumulative Damage in Life-Cycle Modeling; 2004; Yang, Zhifu ; Weiss, W Jason; Olek, Jan; Joint Highway Transportation Program; Indiana DOT, Purdue University  <a href="http://docs.lib.purdue.edu/jtrp/">http://docs.lib.purdue.edu/jtrp/</a></p>	Cracking, NDT, Detection, Measurement
		<p>While uncracked concrete exists as the best case scenario, frequent cracking occurs in real structures that could have a profound impact on life cycle performance. Cracks from several sources may accumulate and interact thereby accelerating the deterioration of concrete. For example, the distributed cracking caused by freeze/thaw damage can substantially increase the rate of water absorption and reduce the load carrying capacity of concrete. To accurately simulate the performance of actual concrete facilities, the role of cracking and its cumulative effect on the changes of material properties was intended to be accounted for in these models. The main goal of this investigation was to assess the influence of cumulative damage in concrete and to quantify its influence for use in life-cycle performance modeling. Samples were taken from five concrete pavement sections based on age, traffic, and overall performance to assess existing damage and to identify possible sources responsible for inducing the damage. These results were used as a baseline to assess the types of damage that merited laboratory investigation. After the field assessment, laboratory investigations were conducted to simulate the damage that may be expected in the field. After various levels of damage were introduced in laboratory specimens, durability tests (freezing and thawing and water absorption) and direct tensile tests were performed to develop an understanding of how the pre-existing damage accelerated the deterioration process. Specifically, it was determined that cracks caused by freezing and thawing dramatically increase the rate and amount of water absorption while cracks caused by mechanical loading only increased the absorption in a local region. Further, freeze-thaw damage dramatically reduces the direct tensile strength and modulus of elasticity of concrete until the aggregates begin to pull out of the matrix. This results in a larger fracture process zone in the damaged concrete than in the undamaged concrete.</p>	
3.5-12	VTRC 08-CR4	<p>Bridge Deck Service Life Prediction and Costs, Gregory Williamson, Richard Weyers, Michael Brown, Michael Sprinkel; Virginia DOT, Virginia Polytechnic Institute, Virginia Transportation Research Council, 2008</p>	Bridge Deck Deterioration, Chloride

<b>Modeling and Discussing Bridge Deck Impacts due to Overweight Trucks and Environmental Effects</b>			
Reference No.	Document No.	Document Title and Link	Relevance to Study
		<a href="http://www.virginiadot.org/vtrc/main/online_reports/pdf/08-cr4.pdf">http://www.virginiadot.org/vtrc/main/online_reports/pdf/08-cr4.pdf</a>	Contamination
<p>The service life of Virginia’s concrete bridge decks is generally controlled by chloride-induced corrosion of the reinforcing steel as a result of the application of winter maintenance deicing salts. A chloride corrosion model accounting for the variable input parameters using Monte Carlo resampling was developed. The model was validated using condition surveys from 10 Virginia bridge decks built with bare steel.</p> <p>Life cycle cost analyses were conducted for polymer concrete and Portland cement based overlays as maintenance activities. The most economical alternative is dependent on individual structure conditions. The study developed a model and computer software that can be used to determine the time to first repair and rehabilitation of individual bridge decks taking into account the time for corrosion initiation, time from initiation to cracking, and time for corrosion damage to propagate to a state requiring repair.</p> <p><i>Virginia DOT uses the chloride contamination and intrusion mechanism in concrete to develop a predictive model based game theory on RC deck deterioration. Then it uses a life cycle cost analysis to determine the best course of action to preserve deck life. This modeling approach, however does not include the effect of axle load induced crack propogation as a factor in deck deterioration.</i></p>			
3.5-13	CEE-RR - 2013/02	Development and Validation of Deterioration Models for Concrete Bridge Decks; Phase 2: Mechanics based Degradation Models, Nan Hu, Syed Haider, Rigoberto Burgueno, Michigan DOT, Michigan State University <a href="http://www.michigan.gov/documents/mdot/RC-1587B_435818_7.pdf">http://www.michigan.gov/documents/mdot/RC-1587B_435818_7.pdf</a>	Bridge Deck Deterioration, Chloride Contamination
<p>This report summarizes a research project aimed at developing degradation models for bridge decks in the state of Michigan based on durability mechanics. A probabilistic framework to implement local-level mechanistic-based models for predicting the chloride-induced corrosion of the RC deck was developed. The methodology is a two-level strategy: a three-phase corrosion process was modeled at a local (unit cell) level to predict the time of surface cracking while a Monte Carlo simulation (MCS) approach was implemented on a representative number of cells to predict global (bridge deck) level degradation by estimating cumulative damage of a complete deck. The predicted damage severity and extent over the deck domain was mapped to the structural condition rating scale prescribed by the National Bridge Inventory (NBI). The influence of multiple effects was investigated by implementing a carbonation induced corrosion deterministic model. By utilizing realistic and site-specific model inputs, the statistics-based framework is capable of estimating the service states of RC decks for comparison with field data at the project level. Predicted results showed that different surface cracking time can be identified by the local deterministic model due to the variation of material and environmental properties based on probability distributions. Bridges from different regions in Michigan were used to validate the prediction model and the results show a good match between observed and predicted bridge condition ratings. A parametric study was carried out to calibrate the influence of key material properties and environmental parameters on service life prediction and facilitate use of the model. A computer program with a user-friendly interface was developed for degradation modeling due to chloride induced corrosion.</p>			

<b>Modeling and Discussing Bridge Deck Impacts due to Overweight Trucks and Environmental Effects</b>			
Reference No.	Document No.	Document Title and Link	Relevance to Study
		<p><i>This study is similar to the Virginia DOT study on RC deck deterioration in terms of approach and modeling. Similar to the VDOT study, no attempt is made to account for the effects of truck axle loads. In terms of policy and strategy to prolong the bridge deck life, the agency uses a different approach. In this study the DOT is using empirical data or the current deck condition ratings to verify the deterioration progression.</i></p>	
3.5-14	FHWA/TX-12/0-6348-2	Bridge Deck Reinforcement and PCP Cracking: Final Report; Oguzhan Bayrak, Shih-Ho Chao, James O. Jirsa, Richard E. Klingner, Umid Azimov, James Foreman, Stephen Foster, Netra Karki, Ki Yeon Kwon, and Aaron Woods; Center for Transportation Research, The University of Texas; TXDOT, 2010 <a href="http://www.utexas.edu/research/ctr/pdf_reports/0_6348_1.pdf">http://www.utexas.edu/research/ctr/pdf_reports/0_6348_1.pdf</a>	Bridge Deck Cracking
		<p>Bridge decks composed of precast, pre-stressed panels (PCPs) overlain by cast-in-place (CIP) are popular in many states, including Texas. Optimization of top-mat reinforcement and reduction of collinear panel cracking were addressed in this project. Longitudinal top-mat reinforcement was found to be already optimized. Further optimization of transverse top-mat reinforcement is possible by slightly reducing the area of deformed reinforcement or by using welded-wire reinforcement. Collinear panel cracking can be reduced by reducing the initial pre-stress or by placing additional transverse reinforcement at panel ends. Measured pre-stress losses in PCPs were at most 25 ksi, much less than the 45 ksi previously assumed by TxDOT. The comparative efficiency of different types of high-performance steel fibers was examined. Double-punch testing, appropriately standardized as proposed in this report, was found to be a reliable and repeatable measure of the comparative efficiency of high-performance steel fibers.</p>	
3.5-15	PWRI Report 5-2tanaka	Fatigue and Corrosion in Concrete Decks with Asphalt Surfacing; Yoshiki Tanaka, Jun Murakoshi, Yuko Nagaya, Public Works Research Institute, Japan (PWRI, Japan) <a href="http://www.pwri.go.jp/eng/ujnr/tc/g/pdf/25/5-2.pdf">http://www.pwri.go.jp/eng/ujnr/tc/g/pdf/25/5-2.pdf</a>	RC Deck Fatigue; Corrosion
		<p>In 20th century, a large number of highway bridge reinforced concrete bridge decks in the U.S. suffered from corrosion due to deicing salt, however, similarly constructed bridge decks in Japan suffered from fatigue due to the cyclic loading of heavy truck axles. Lately, significant corrosion of concrete decks due to deicing salt have also been reported in Japan, giving rise to further concerns about combined deterioration from fatigue and corrosion in existing bridge decks designed according to old specifications. This paper provides a comparison of bridge decks chloride profiles in asphalt covered concrete decks in Japan and bridge decks in the US to see if there was a significant difference in deterioration rates. Additional research was conducted on the decks with regard to the interaction chloride contamination with RC concrete fatigue mechanisms with the rate of deterioration using dynamic wheel load testing.</p> <p><i>The study provided some insight in the behavior of concrete decks with regard to fatigue and studies the rate of deterioration of concrete decks when impregnated with chloride salts. However, there was no direct interactive testing of the two deterioration mechanisms that of are direct interest to the deterioration mechanism under study.</i></p>	
3.5-16	PWRI Report	Fatigue Durability of Reinforced Concrete Deck Slab in a Cold Snowy Region; Takashi Satoh, Hiroshi Mitamura, Yutaka	RC Deck Fatigue;

<b>Modeling and Discussing Bridge Deck Impacts due to Overweight Trucks and Environmental Effects</b>			
Reference No.	Document No.	Document Title and Link	Relevance to Study
	23-2-4satoh	Adachi, Hiroaki Nishi, Hiroyuki Ishikawa and Shegeki Matsui; Civil Engineering Research Institute for Cold Region (CERI); PWRI, Japan <a href="http://www.pwri.go.jp/eng/ujnr/tc/g/pdf/23/23-2-4satoh.pdf">http://www.pwri.go.jp/eng/ujnr/tc/g/pdf/23/23-2-4satoh.pdf</a>	Corrosion
	<p>Repetitive wheel loading from heavy vehicles are known to be the major cause of the deterioration and fatigue failure of reinforced concrete (RC) deck slabs on road bridges. Additionally, the intrusion of rainwater into cracks significantly reduces the fatigue durability of RC decks. Other environmental conditions also accelerate the deterioration. In Hokkaido, the extreme cold causes freeze-thaw damage, and the spreading of deicing agents causes chloride damage. In order to manage the repair of RC decks in a cold region, it is necessary to determine how their states of deterioration relate to their lifespans. To study the fatigue durability of deck slabs, we performed fatigue tests using a wheel tracking test machine. Test specimens were cut from a bridge that was in service in Hokkaido for forty years and was tested to failure. Stress – cycle curves were developed to help predict the service of life RC decks.</p> <p><i>More insight was gained from this testing approach, however there are some obvious flaws in this study. The first 40 years of the deck was in the field experiencing real truck axle loads, cold wet climate and use of de-icing salts, however the number of axle load cycles over the 40 years can at best be estimated</i></p>		
	<p>In addition, for documents referencing Modeling and Discussing Bridge Deck Impacts due to Overweight Trucks and Environmental Effects see “Reference Nos.”: 2.3.6-4; 2.3.6-13</p>		

### **3.6 Conclusion**

The reports, studies and articles presented above represent available information that is currently available from on-line university libraries, industry publications, State and Federal transportation agencies and other government and/or industry web sites. The collection provides a snapshot of ideas, methods, and research efforts from 1997 to 2013. Many articles and papers have been added to this edition of the Desk Scan since it was first released to the FHWA in November 2013. Every effort has been made to provide a link to every article, however a few of them are part of online libraries that require accounts and paid subscriptions. We obtained those articles through special requests from the CDM Smith InfoCenter, which has access to many of the private libraries. All the articles and documents that are sighted herein address the key issues that were investigated in the 2014 CTSW Study as they relate to bridges.

## CHAPTER 4 – LIST OF AGENCIES

### **4.1 National Academy of Sciences**

TRB – Transportation Research Board  
National Cooperative Highway Research Program - NCHRP  
Strategic Highway Research Program - SHRP 2  
Conferences: International Bridge Conference, IBC

### **4.2 Federal and State Transportation Agencies**

United States Department of Transportation (USDOT)  
Federal Highway Administration (FHWA)  
    Turner Fairbanks Research Center  
    Long Term Bridge Performance  
Arizona – ADOT  
California-CalTrans  
Colorado – CDOT  
Illinois – IDOT  
Indiana – INDOT  
    Joint Transportation Research Program (JTRP)  
Kentucky – KDOT  
    Kentucky Transportation Cabinet  
Louisiana – LDOT  
    Louisiana Transportation Research Center  
Maryland – MDTA (MD SHA)  
Michigan- MDOT  
Minnesota – (MnDOT)  
Nebraska - NDOR  
Nevada - NVDOT  
New York  
    NYSDOT, NYCDOT  
Ohio - ODOT  
Oregon – ODOT  
Tennessee – TDOT  
Texas – TXDOT  
Vermont – VAT  
Washington DC – District DOT  
Wisconsin – WisDOT

### **4.3 Universities**

Carnegie-Mellon University  
Case Western Reserve University  
City University of New York  
Louisiana Tech University  
Lehigh University



Purdue University  
Rensselaer Polytechnic Institute  
University of Kentucky  
University of Nebraska (Lincoln)  
University of Texas (Austin)  
City University of New York (CUNY)  
University of Leeds (Coordinator of CATRIN Study)

#### **4.4 Industry Standards and Publications**

AASHTO - American Association of State Highway Transportation Officials  
ASCE – American Society of Civil Engineers  
    Journal of Structural Engineering  
    Journal of Bridge Engineering  
AISC - American Institute of Steel Construction  
    (NSBA) National Steel Bridge Alliance  
ACI - American Concrete Institute  
PCI – Precast Concrete Institute

#### **4.5 Foreign Resources**

Canada – Transportation Association of Canada  
UK - English Highway Agency  
European Transport Commission:  
    (Cost Allocation of TRansit Infrastructure, CATRIN)  
    (UNification of Accounts and Marginal Costs for Transport Efficiency, UNITE)  
    (Generalization of Research on Accounts Cost Estimation, GRACE)  
    Dutch Ministry of Transport  
Poland:  
    General Directorate of National Roads (GDDKiA)  
    Road & Bridge Research Institute (IBDiM)  
    Swedish Road Administration (SRA)  
Australia:  
    Australian Transport Council (ATC)  
    National Transport Commission (NTC)  
    Australian Road Research Board (ARRB)  
Japan: Public Works Research Institute

## APPENDIX B – BRIDGE PROJECT PLAN/SCHEDULE

This Plan lays out a detailed project plan specific to the bridge task for the Comprehensive Truck Size and Weight Limits Study (Study). The plan includes an overview of the methodology that will be used and detailed step by step procedures and chronological descriptions of the various subtasks. This task also includes a detailed Critical Path Method (CPM) type schedule chart showing durations, dependencies and milestones.

### Summary - Bridge Task Plan, General Approach

There are two main objectives to the Bridge Task Plan; the **first objective** is the determination and assessment of the implications of the structural demands on US bridges due to the current truck fleet (base case, Gross Vehicle Weight  $\leq$  80,000 lbs.), vs. those due to the ‘modal shift’ fleet to be anticipated in the event that the proposed alternative vehicles (truck configurations with GVW  $>$  80,000 lbs. and twin thirty-three foot trailer combinations at 80,000 lbs.). The **second objective** is to determine the bridge related cost impacts for the current truck fleet (base case) vs. those to be anticipated as a result of the ‘modal shift’ with the proposed alternative vehicles. Both of these studies will be conducted with respect to bridges located on three ‘highway scenarios’: 1) the Interstate system; 2) Primary Arterials; and 3) all other highways comprising the NHS and/or the National Truck Network.

The following related sub-tasks will also be investigated and assessed with respect to the degree to which they may be affected by the legalization of the proposed alternative vehicles on a national basis:

- Estimate Relative Damage Risk Levels to Bridges Due to Inelastic Deformation
- Fatigue Related Effects – Research and summarize the effects of overweight trucks on the fatigue life of bridges
- Posting Assessment – Estimate the number of additional bridges requiring posting, retrofitting or replacement
- Bridge Deck Repair & Replacement Costs - Study & assess the effects of proposed alternative vehicles (truck configurations) on bridge decks and the resulting rehabilitation and replacement costs
- Bridge Deck Preservation & Maintenance Costs

These reports will appear as independent sections in the final report and will most likely be an assessment, resulting from the findings of the Study main objectives listed above and augmented with research of available literature.

### Schedule

- The Preliminary Project Plan (consisting of the structural report and the cost allocation report for the base case) will be submitted on February 28, 2014.
- The Final Draft Report (including all the sub studies) will be submitted on April 30, 2014.

### **1.3 Detailed Project Plan for V.C.3 – Comparative Analysis of Truck Weight Impacts on Bridges**

***Investigate and Assess the Structural Demands of Legal and Overweight Trucks on Bridges:*** A group of 500 bridges representing the 20 +/- most common bridge types will be selected from four regions throughout the contiguous United States. Hawaii and Alaska combined have only 2143 bridges, so their numbers will be rolled into reasonably similar climatic regions. The AASHTOWare Bridge Rating<sup>®</sup> (ABrR) program will be used to analyze the 500 bridges for legal trucks (base case, GVW  $\leq$  80,000 lbs.) and for the proposed alternative vehicles (alternative scenario, GVW  $>$ 80,000 lbs.).

The truck classifications for the base case and for the alternative scenario used for this Study consist of the following 3 configurations:

- 1) Five axle (3-S2) tractor semitrailer (53'), GVW  $\leq$  80,000 pounds (base case)
- 2) Five axle (3-S2) tractor semitrailer (53'), GVW  $\leq$  88,000 pounds (alternative scenario)
- 3) Six axle (3-S3) tractor semitrailer (53'), GVW  $\leq$  97,000 pounds (alternative scenario)

And Longer Configuration Vehicles (LCV) as determined following the May 29, 2013 Outreach Meeting:

- 4) Surface Transportation Assistance Act (STAA) Tractor-Semitrailer-Trailer combination with twin 28.5 foot trailers (alternative scenario)
- 5) Tractor-Semitrailer-Trailer (Twin 33' tractor-semitrailer-trailer configuration complying with current Federal weight limits)
- 6) Tractor-Semitrailer-Trailer-Trailer (Triple tractor-semitrailer-trailer-trailer with three 28.5' trailer units)

**The five steps required to achieve this objective are:**

- 1) Determination of the regions, for bridge purposes
- 2) Selection of the 500 representative bridges
- 3) Obtaining the ABrR bridge models in LRFR (& LFD) capable format
- 4) Analyzing the bridges for the various truck configurations and obtaining demand moments and rating factors
- 5) Presenting the results of the structural analysis, including in tabular and graphical form.

**Determination of Regions:** The States will be subdivided into four climatic regions (not necessarily coincident with the Pavement Subtask Climatic Regions). The rationale for the subdivision would also reflect, to the degree possible, truck classifications that are unique to a State or area.

Due to the inherent limitations imposed by the scope and duration of this Study, the analysis to be performed has been limited to studying 4 regions. For the Washington D.C. DOT Study of the effects of overweight trucks (2011), a bridge deterioration model was developed that reflected a primary deterioration mechanism and path for cold weather states that apply winter salts to control ice and snow. It is preferable to study a region inclusive of Northern States where environmental factors can be said to be generally similar to the Northeast, but where there is a history of the acceptance of heavier trucks. This region would include Michigan, Ohio and Indiana, and would present some interesting potentials for cost comparisons. The Southwest is interesting in offering a base condition area where climatological factors may be minimal. If the modal fleet analysis cannot accommodate this regional segregation of data over and above that being used in other areas of the Study; it is envisioned that the

common regional definitions will be worked with as those definitions may be uniformly defined across all areas of the Study.

**Bridge Selection Criteria:** 500 bridges will be selected that will represent the States within each of the 4 regions, and the 20+/- most common bridge types (based on superstructure material, design type and continuity) as defined by the National Bridge Inventory and Appraisal Coding Guide (FHWA-PD-96-001).

**Table 33** is a representation of various bridge types that might be considered for study. The number in each cell in the table is not a numerical count, but rather an address in the bridge type coding matrix. For example, ‘104’ represents Concrete Tee-Beams. The NBIS data base will be sorted to first determine the number of bridges of each ‘bridge type’, in each region, on each of the three ‘highway scenarios’. In this example the white colored cells might be chosen as the statistically most prevalent bridge types in that region, and by design would collectively represent at least 90 percent of the bridges in the region. To the extent possible, and as may be limited by the availability of ABrR LRFR bridge analysis models, bridges will be chosen for analysis in accord with the proportion of their bridge types throughout that region.

**Table 33: Partial Bridge Type Matrix**

Design →	Slab	Stringer	Girder/FB	Tee Beam	Box Multiple	Box Single	Frame	Orthotropic	Truss Deck	Truss Thru	Arch Deck	Arch Thru
Material / construction ↓												
Concrete	101	102	103	104	105	106	107	-	109	110	111	112
Concrete continuous	201	201	203	204	205	206	207	-	209	210	211	212
Steel	-	302	303	304	305	306	307	308	309	310	311	312
Steel continuous	401	402	403	404	405	406	407	408	409	410	411	412
Prestressed Concrete	501	502	503	504	505	506	507	-	-	-	-	-
Prestressed Concrete continuous	601	602	603	604	605	606	607	-	-	-	-	-
Wood or timber	701	702	703	704	-	-	705	-	-	-	-	-
Masonry	-	-	-	-	-	-	-	-	-	-	811	-
Aluminum, Wrought Iron	-	-	-	-	-	-	-	-	-	-	-	-
Other	-	-	-	-	-	-	-	-	-	-	-	-

**Color Legend:**

	Most Likely to be found on highway scenario under consideration
	May be found on highway scenario
	Bridge Type is not statistically representative
	Bridge Type - material/structure combination not likely to used together

From **Table 33**, we compiled a list of the 22 Bridge Types (Material and Design Type) that would likely be included in the Study. See **Table 34** Representative bridge types.

The intent here is to select bridges that are statistically representative of each region by bridge type, span(s) length and by deck area proportionately in each region. This will aid in drawing conclusions and applying inferred knowledge consistently.)

**Table 34: Bridge Type Compilation**

Bridge Type No.	Mater./Design Code	Material Design	On Interstate / Arterial ?	On NHS ?	ABrR® Model Available ?
1	101	Concrete Slab	<input type="checkbox"/>	<input type="checkbox"/>	LRFR
2	201	Concrete Continuous Slab	<input type="checkbox"/>	<input type="checkbox"/>	LRFR
3	501	Pre-stressed Concrete Slab	<input type="checkbox"/>	<input type="checkbox"/>	LRFR
4	601	Pre-stressed Concrete Slab Continuous	<input type="checkbox"/>	<input type="checkbox"/>	LRFR
5	102	Concrete Stringer	<input type="checkbox"/>	<input type="checkbox"/>	LRFR
6	202	Concrete Continuous Stringer	<input type="checkbox"/>	<input type="checkbox"/>	LRFR
7	302	Steel Stringer	<input type="checkbox"/>	<input type="checkbox"/>	LRFR
8	402	Steel Continuous Stringer	<input type="checkbox"/>	<input type="checkbox"/>	LRFR
9	502	Pre-stressed Concrete Stringer	<input type="checkbox"/>	<input type="checkbox"/>	LRFR
10	602	Pre-stressed Concrete Stringer Cont.	<input type="checkbox"/>	<input type="checkbox"/>	LRFR
11	303	Steel Girder / floor-beam	<input type="checkbox"/>	<input type="checkbox"/>	LFD
12	403	Steel Girder / floor-beam Cont.	<input type="checkbox"/>	<input type="checkbox"/>	LFD
13	104	Concrete Tee Beam	<input type="checkbox"/>	<input type="checkbox"/>	LRFR
14	204	Concrete Tee Beam Cont.	<input type="checkbox"/>	<input type="checkbox"/>	LRFR
15	504	Pre-stressed Concrete Tee Beam	<input type="checkbox"/>	<input type="checkbox"/>	LRFR
16	604	Pre-stressed Concrete Tee Beam Cont.	<input type="checkbox"/>	<input type="checkbox"/>	LRFR
17	309	Steel Truss Deck	<input type="checkbox"/>	<input type="checkbox"/>	LFD
18	409	Steel Truss Deck Continuous	<input type="checkbox"/>	<input type="checkbox"/>	LFD
19	310	Steel Truss Thru	<input type="checkbox"/>	<input type="checkbox"/>	LFD
20	119	Concrete Culvert	<input type="checkbox"/>	<input type="checkbox"/>	-
21	219	Concrete Culvert Continuous	<input type="checkbox"/>	<input type="checkbox"/>	-
22	319	Steel Culvert	<input type="checkbox"/>	<input type="checkbox"/>	-

**Obtaining the ABrR Bridge Models in Load and Resistance Factor Rating (LRFR) Capable Format:**  
 The primary early use of this data segregation will be to determine how many ABrR bridge models will be needed for each bridge type, on each highway scenario, in each region. As of this writing, approximately 38 States use the AASHTO ABrR load rating program. A search for the appropriate bridge models from the various States in representative quantities will be conducted as part of this effort.

**Running the AASHTO Bridge Rating Program (ABrR®):**  
 Bridge models for the selected bridges in the various regions as described above will be obtained. As previously referenced, the 500 bridges will be analyzed in ABrR utilizing the LRFR rating method for the 80k lb. ‘base case’ vehicle’ and for the rating vehicle, as well as for the five (5) alternative scenario vehicles listed above. The controlling moments, and load rating factors will be extracted for each bridge and tabulated.

Present the Results of the Structural Study:

For each bridge type an assessment and comparison will be performed:

- The structural demands (expressed as moment) imposed on the specific bridges by each alternative vehicle (truck configuration), compared to those imposed by the 80k lb. ‘base case’ vehicle and by the rating vehicle (generally the H-20, HS-20 or the H25, HS25)
- The rating factors derived for each alternative vehicle
- Whether any indicated increase is structurally significant

In addition we will:

- Determine the number of those of the 500 representative bridges that would appear to require posting, rehabilitation or replacement
- Extrapolate proportionally & statistically to bridges nationwide, and comment on the reasonableness of that extrapolation
- Plot scatter diagram to infer and establish trends for discussion and explanation

The findings will be presented in tabular and graphic form and will provide detailed explanation with respect to the overall structural impact on these representative bridges, both due to the ‘alternative vehicles’ as a group and as may be the case, individually. For instance, it may be that certain of the alternate vehicles have serious structural implications for certain bridge types of spans greater or less than a threshold value.

**Bridge Task Cost Allocation**

The base bridge costs for this Study will be derived from the Financial Management Information System (FMIS) summaries for the States. FMIS contains project cost information at the project phase level and will be useful in estimating typical structural repair and replacement costs required in this analysis.

Cost Responsibility Process: The goal of the cost responsibility process is to assign bridge cost responsibility to the broad vehicle groupings relevant to this Study, including those of the proposed alternative vehicles. While not a full cost allocation study, per se, there is a need to understand the cost responsibilities of various truck groupings (ie: trucks operating at and below current Federal size and weight limits as opposed to trucks that operate above those limits). At the end of this section, the a concise discussion of other methods used in Cost Allocation Studies in the US, Europe and Australia is found which were found helpful in framing the work in this area of the Study.

In a number of States as well as in some other countries, axle load based allocations have been used for bridge costs. These agencies have used various and diverse allocators and exponents to develop expressions of incremental damage. As reported in prior studies, 59 percent to 70 percent of all bridge capital costs are non-load-related, or in other words, attributable to environmental factors and light weight vehicle use, etc. In the Northeast, we would attribute about 60 percent of all bridge capital costs to these non-load-related factors; and perhaps in the southwest (cold-dry region) it would be closer to 70 percent. The 2000 FHWA funded “Guidelines for Conducting a State Highway (and bridge) Cost Allocation Study” included examples with as much as 79 percent assumed to be non-load related. An additional factor to be studied on a regional basis with respect to this issue is the percent of bridge capital costs attributable to new construction, driven by development, population growth and investment.

The five steps (sub tasks) in the allocation of the remaining 35 percent ± of Bridge Costs are listed below: (Also see **Figure 37** for a work flow summary)

- 1) Collect statewide WIM data. (provided by other task leads)
- 2) Summarize the WIM data by region and normalize it based on the number of WIM stations by highway scenario and by the total square footage of deck of each State in the region. This will produce 12 sets of working WIM data: three sets of data for each region. The data will consist of recorded counts of axle weights in increments of 1,000 lb. for single axles, 2000 lb. increments for tandems, etc. for each vehicle class.
- 3) Compute the standardized axle weight ratio for each axle weight increment
- 4) Development of Load Related, Relative Damage Shares (RDS): Overall bridge ‘damage’ has been judged in various studies to relate to axle load by varying exponents, ranging from 1.5 to as much as 3.0 (in Finland they used 4.0).
  - Some direct load induced effects, as well as progressive micro-cracking and long-term concrete fatigue in decks appear to be essentially linear with respect to load.
  - A significant component of bridge deterioration in the North is driven by joint failure and localized shear plain failure at joints and cracks, and is induced by axle weight impacts. This initiates a deterioration mechanism that progressively affects bearings, pedestals, caps and the substructure. It is grossly accelerated by the application of chlorides to control snow and ice in Northern States.
  - One of the primary areas that has been identified is the research and development of the composite exponential relationship between: 1) bridge damage costs and that portion of cumulative bridge damage, to 2) the composite axle loading as represented by the normalized WIM data. Reflecting the varying environmental conditions by region, the net or composite exponent can be seen to vary somewhat by region.
  - In addition to the cited literature search, a preliminary statistical sensitivity analysis has been conducted and it appears to confirm that a composite exponent of between 1.5 and 3.0 is appropriate.
  - Load Related, Relative Damage Shares (RDS) -Using a spread sheet application, the standard axle weight ratio for each axle weight increment is first raised to the power of the composite exponent derived above and then is multiplied by the number of axles recorded at that weight increment for each vehicle class. This is the RDS.
- 5) All RDS are summed for each vehicle grouping. This sum effectively comprises the share of all ‘damage’ attributable to that vehicle grouping. The share of costs (damage) attributable to that vehicle grouping is determined by the ratio of its sum of RDS’s divided by the collective sum total of all RDS’s for all truck classes. That ratio is applied to the portion of all bridge capital costs (approximately 35 percent) attributable to truck loads. See **Table 35**.

**Table 35** is a depiction of the spread sheet based allocation of damage related costs by vehicle class for a particular exponential relationship between bridge damage costs and axle weights by vehicle class.

**Table 36** shows the percent of total bridge costs allocated by vehicle category for the WIM data listed in **Table 35**. It shows the percent for the existing fleet and for the future, ‘modal shift’ fleet. An important benefit of this approach is the capture of damage related costs attributable to each truck class. A second major benefit is that we can directly establish the relative total bridge capital costs attributable to the introduction of alternative proposed vehicles.

**Table 35: WIM Observation Data with Summation of Relative Damage Shares (RDS)**

District of Columbia		WIM Observations (1st Column = Axle Counts, 2nd Column = RDS (Damage))					
		Single Axles Counts >		SU2		SU3	
Single Axle (kips)	Standardized Axle Wt. Factor	Bus		SU2		SU3	
3	0.00554	348	1.927	855982	4740.520	1030	5.704
4	0.01276	520	6.633	447790	5711.604	660	8.418
5	0.02436	802	19.539	240866	5868.110	901	21.951
6	0.04134	2052	84.825	185063	7650.115	1777	73.457

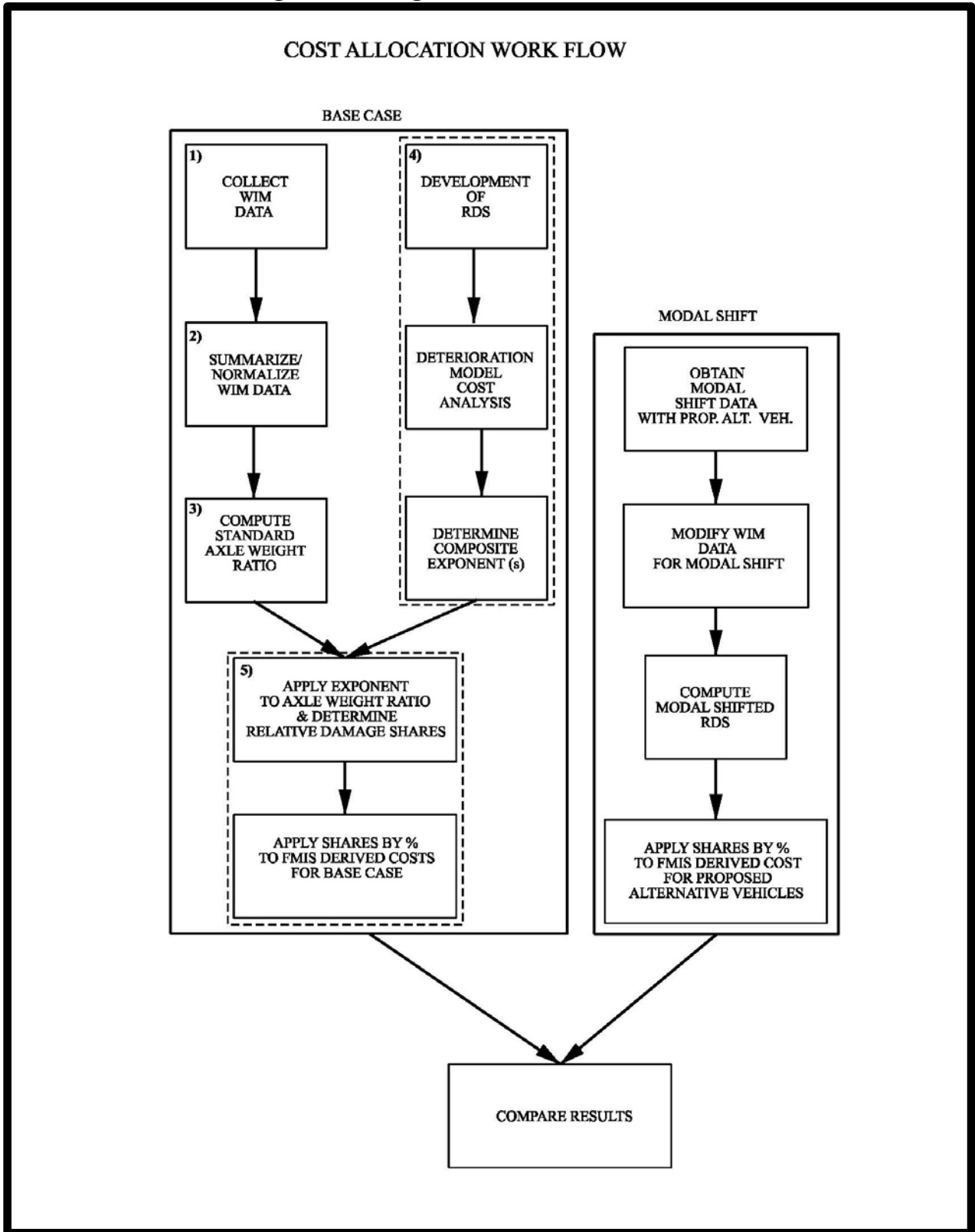
38	8.73137	54	471.494	209	1824.855	2	17.463
39	9.41450	46	433.067	255	2400.697	1	9.414
40	10.13173	81	820.670	1135	11499.516	7	70.922
$\Sigma$ of Axles ; $\Sigma$ Factor >		695785	699918.133	2478515	305028.990	284016	169652.679
$\Sigma$ Legal Axles; $\Sigma$ RDSs		535110	238312.571	2449175	203817.892	268345	130036.396
$\Sigma$ Overweight Axles; $\Sigma$ RDSs		160675	461605.561	29340	101211.097	15671	39616.283

**Table 36: Hypothetical Damage Distribution Profile Prior to and After Modal Shift**

Vehicle Class	Allocation (%)	
	Pres. Flt.	Fut. Flt.
Passenger Cars & Light Trucks < 26K GVW	65.0	65.0
26K Trucks to < 80 K Trucks	15.6	12.7
80K Trucks (5 axle, 3-S2)	18.2	9.3
88K Trucks (5 axle, 3-S2)	0	5.5
97K Trucks (6 axle, 3-S3)	0	2.7
STAA Tractor-SemiTrailer-Trailer (Twin 28.5' Trailers)	0.5	2.1
Tractor-SemiTrailer-Trailer (Twin 33' Trailers)	0.35	1.9
Tractor-SemiTrailer-Trailer-Trailer (Triple Trailer Units)	0.35	0.8
Totals	100.0	



Figure 37 Bridge Cost Allocation Work Flow



Modal Shift – Effect of Alternative Vehicle Scenario on Bridge Costs: The process here is essentially the same as for the Base Case, except that the WIM data will be modified to reflect the number of trucks of various vehicle classes in the proposed Alternative Vehicle Fleet. The modal shift data will be developed in by the Modal Shift analysis work of the Study in terms of percentage increase in number of axles for each truck classification. As before the standard axle rate ratios will be raised to the exponent value determined in Step 4 above and the RDS for the modal shift will be computed. The results will be applied to the FMIS cost data.

Having sets of results for both the existing truck fleet and the proposed truck fleet in hand, a comparative analysis can be made, answering in relative terms what is the cost impact of the proposed fleet of vehicles.

Other Cost Allocation Methods: A number of different cost allocation methodologies were reviewed. The most prevalent method used in the United States in the past decade (1997 – 2012) has been the Federal Method, as described in the NCHRP Report 495, which is derived from the 1997 FHWA Highway Cost Allocation Study. Both of these documents are a refinement of the previous Incremental methods developed in the 70's and 80's. The Federal method has been developed for use by individual States and/or local highway network authorities and has not yet been adapted to any national or even regional studies. To implement the Federal method on a national scale would require a level of detail not available in the NBIS and potentially not available at all. The information required would include: detailed structural data for each bridge; bridge specific condition data; and detailed cost/expenditure data for each State. The project schedule is not conducive to undertaking this effort. States have used the Federal method in modified formats to allocate bridge costs along with varied allocators (Vehicle Miles of Travel-VMT, Passenger Care Equivalents-PCE or Equivalent Single Axle Loads-ESALs) for different bridge elements or for other bridge related costs. It should be stressed that there is no uniformity or consensus in regard to what is included in a bridge allocation study. Perhaps most importantly, the States have designed the methodologies used in those studies to answer different questions.

The 'Federal Method' may not be capable of generating the cost allocation estimates at the level of detail envisioned under this Study or with a similar degree of transparency as would be desirable to have for a study of this national scale. However, some aspects of the Federal method (as set forth in NCHRP Report 495, "Effect of Truck Weights on Bridge Network Costs") could augment the explanation and approach being applied in this work area. This is particularly true of the emphasis on shear stress in concrete decks.

Methodologies used in Europe and Australia were also reviewed. The E.U. Cost Allocation of Transport Infrastructure (CATRIN) synthesis document of 2008 is a summary of methods of cost allocations used in the transportation industry (including roadways, railway, air transport and maritime) in Europe. They approach the allocation of roadway costs (including bridges) from an 'econometric' or top-down approach as well as from an 'engineering' or bottom-up approach. What is clear from this document is that there is a huge disparity of approaches between these countries due to: data availability, cost categories, elements, etc. In the end the document does not sum up the cost responsibilities from each country, but rather summarizes the 'approaches' in tabular form. It can be surmised from this tabular matrix is that load based allocators were used for highway (roads and bridges) cost allocation. The Netherlands, the Dutch and the Swiss used them on their roadways and then broke out bridges as a

percentage of overall costs. The Finnish used them directly in their bridge cost allocation. No new engineering methods were introduced as part of this work.

The Australian Method, as reported in the National Transport Commission's 'Third Heavy Vehicle Road Pricing Determination Technical Report' (October 2005), uses a number of allocators to determine shares of vehicle cost responsibility. The study lumps all costs under "roadway" costs and then breaks out pavement and bridge costs. Bridge costs are compiled from the various State and Territory transport industries and are categorized as Attributable and Non-attributable Costs. Original and new construction costs of bridges are considered as Non-attributable costs, and are allocated by vehicle usage or Vehicle Kilometers Travelled (VKT). These costs were estimated at 85 percent of all bridge costs. The Attributable Costs includes preservation and maintenance, repairs and rehabilitation. The Attributable bridge cost, estimated at 15 percent of all costs, was allocated based on Passenger Car Equivalent Units (PCEUs). The Australian report acknowledged that there was a relationship between load based allocators and bridge deterioration, but it stopped short of suggesting a method other than using Passenger Car (Equivalent) Units. The report states "For other non-pavement expenditure (*i.e.*, bridge) categories, there is little international consensus, and little information on which to judge to what extent alternative approaches might be applicable to Australia." In other words, the Australian Report does not endorse any other method for allocating bridges. The Australian Report, however, does present some apparent advantages that could be considered for implementation in this Study. The Australian Bureau of Statistics (ABS) conducts a comprehensive, national Survey of Motor Vehicle Use – SMVU, which includes statistics on an annual basis on the number of vehicles, Vehicle Kilometers Traveled (VKT), fuel consumption and average gross mass (AGM) of all vehicles. It collects this data on 35 vehicle classifications (from motorcycles to passenger cars to busses and trucks), by roadway classification (main highway, arterial, local etc.) and on a State by State basis. Something like this would greatly facilitate any future Truck Size and Weight Study.

### **Studies & Assessments:**

In addition to the main objectives of this report, the Bridge Task includes additional sub-task (studies) that are designed to address specific questions or issues related to the overall Study. In each of these studies listed below, the results of the main study objectives will be used to answer the questions and/or will augment those findings with additional research of relevant existing literature.

**Estimate Relative Damage Risk Levels Due to Inelastic Deformation:** The difference between the damage risk levels that would be attributable to trucks that comply with current Federal legal limits compared to those resulting from non-compliant trucks will be assessed, described and estimated. This would recognize that key risk factors are often site-specific, including local industry and/or use patterns; but would also include regional load posting compliance behaviors which are statistically verifiable. Structural risk factors associated with the proposed alternative vehicles will be addressed through a detailed review of the results of the LRFR analysis. The limitations imposed by the analysis to be undertaken under this Study will be identified and described in detail in support of any future study that might become advisable.

**Fatigue Related Effects:** The effects of heavier trucks will be assessed and reported in general and effects of the proposed alternative vehicles (truck configurations) will be assessed and reported in particular on the fatigue life of bridges. This area of the Study will focus on three categories of fatigue: load induced and distortion induced fatigue in steel members; and concrete fatigue in bridge decks. The

process includes a research/desk scan phase and a consolidation of the formulaic tools used to determine the safe life of bridge elements in response to these three categories of fatigue. General expressions of the relative effects of increasing truck weight and volume on fatigue life consumption in bridges will be developed. Reflecting on the Desk Scan, related positions and conclusions by others will be identified. Sources such as NCHRP Report 495 (2003) will be relied on to do this. Holding as many factors constant as possible to enable the comparison between the existing truck fleet and the proposed modal shift fleet, the differences in fatigue life consumption in relative terms will be assessed. The scope and, in particular, schedule for this Study will not support exhaustive fatigue analysis of numerous actual bridges, and it is felt that the analysis of only a handful of bridges would not be definitive. Consequently, the character of this important sub-study area will be to adhere to a generalized assessment of fatigue effects. A recommendation for further study on a much larger scale, including perhaps the analysis of a more detailed analysis of a large number of specific, real bridges.

### Steel Fatigue (Load and Distortion Induced)

Fatigue damage to steel bridge elements can result from load induced fatigue effects or from distortion induced fatigue. Traditionally bridge engineers focused their studies of load induced fatigue on un-cracked members, first on the ‘infinite-life check’ process and secondarily on the ‘finite-life check’. Programs for the analysis of Category D, E and E’ details have been readily available for decades. Practical tools and processes are in place and are common practice, most importantly with regard to bridges built prior to 1978. These include regular, periodic inspections; repair of identified or suspected welds and/or material incongruities; retro-fitting, etc. Distortion-induced fatigue is due to secondary stresses in the steel plates that comprise bridge member cross-sections. These stresses and strains can only be calculated with very refined methods of analysis or with instrumentation, and is far beyond the scope of this Study. On newer bridges, the steels are ‘tougher’ or more fatigue resistant; fatigue sensitive details are typically avoided; and improvements of lateral member connections are implemented, for instance: connecting transverse connection plates to both the compression and tension flanges of girders, or coping of connection plates at the web to provide sufficient flexibility in the web itself. The intent is to provide a summary of current understanding with regard to distortion-induced fatigue and its implications for the increased utilization of heavier trucks.

### Concrete Fatigue

The general assessment of concrete fatigue for the existing fleet will be compared to that for the modal shift fleet, based on the formulaic approach set forth in NCHRP Report 495. It infers a great dependence on the ultimate shear capacity of the deck, and states “the useful service life of a bridge deck is a random variable that is a function of a number of other variables: load magnitudes, number of load cycles, and decision as to when it should be renewed...” There is considerable uncertainty with respect to the selection of numerous other parameters, including the Dynamic Impact Factor and the assumed number of axles for the average truck; yet they can have a significant effect on even the calculated “Probability of Deck Life Exhausted in (the) Next 20 Years”. This all serves to show what a difficult process it is to make generalizations about concrete fatigue in decks. However, as noted above, as many parameters as possible will be held constant in order to facilitate an assessment of the effects of an increase in the number of heavier trucks under the modal shift fleet. To facilitate this process, we will develop the ‘Average Truck’ for the two fleet cases, based on a truck weight histogram derived from ‘normalized’ WIM data.

**Posting Assessment:** Those bridges among the 500 to be studied that can be expected to require posting, retro-fitting or rehabilitation in order to accommodate the addition of the heavier ‘alternative’ vehicles to the legal fleet will be assessed. Concurrently, the cost to post, operate and enforce additional postings with regard to bridges that cannot accommodate the alternative configurations and, also, trucks currently operating in excess of Federal limits will be identified as part of the work being conducted in the Enforcement and Compliance area of the Study. This would be based on a survey of costs from representative bridge owning agencies or departments, and on a statistical analysis of all of the bridges on each highway scenario (Interstate, Principal Arterial System or other roadways on the National Highway System or National Network). This cost analysis will consider both: the implications to the national bridge inventory (by extrapolation) of the findings of the structural analysis of the 500 representative bridges; and the effects of increasing Federal weight limits on the number of posted bridges and the effects of these additional postings on the usable truck network. This will include a statistical assessment of the number of bridges on each highway scenario that would require new postings as a result of increased Federal weight limits. For instance, older bridges on the Interstate system were designed to carry the H-20 (40,000 lb.) truck and the HS-20 (72,000 lb.) truck and were designed using ASD or LFD analysis. The LRFR method tends to yield different results relative to ASD and LFD, depending on span length, etc.; but is considered to be more consistently ‘reliable’ in terms of risk assessment. However the implementation of a greater standard weight limit would necessitate the posting of some bridges that may now barely meet the current standard. As an alternate to posting, bridge strengthening options will be investigated and the associated costs will be estimated.

**Bridge Decks – Repair and Replacement Costs:** The intent of this part of the Study is to consider both the change in the frequency and the associated costs for deck rehabilitation or deck replacement that would result from the introduction of the proposed alternative vehicles to the legal fleet. The results of the concrete fatigue study will help to ground the estimate of any change in the estimated deck life of the average bridge. The estimate of additional costs associated with rehabilitating or replacing decks will incorporate unit costs data from various States.

**Preservation & Maintenance of Bridge Decks:** The investigation into the cost impact that the proposed alternate vehicles will have on bridge decks will be addressed in this part of the Study. With respect to maintenance and preservation costs, a search of available literature on current bridge deck preservation efforts that are in place in various States which may have published cost data will be conducted. To augment the study, direct contact with bridge maintenance officials of State agencies will be initiated and information on their bridge maintenance and preservation policies and programs will be pursued. Annual cost data, and will attempt to contact States in all climatic regions. In particular, like Michigan that routinely allow heavier than the ‘base case’ vehicles (80,000 lbs. GVW) on their bridges and other nearby States that do not allow heavier than the ‘base case’ vehicle will be contacted, and information on maintenance cost data will be pursued. These costs by deck square footage will be prorated to determine a ‘cost per square foot of deck’. Distinctions as to what the various States include by definition under the categories of preservation and maintenance will be accounted for or identified. The goal will be to determine what conclusions may be drawn with respect to these costs in States that already allow the heavier vehicles vs. those nearby States that do not. Detailed recommendations for further study of this issue will be made, if appropriate, as they may become clear through the course of this work to be conducted in this area.

## **Reports:**

**Preliminary Report:** The Preliminary Report will include the findings of the initial study objective, namely the results of the Bridge Structural Analysis and Cost Allocation for the Current Fleet of Legal Trucks in use today.

**Final Report:** The Final Report will include results of produced through the technical assessments and a Comparative Analysis of the effects of a Future Legalized Fleet of Vehicles which includes the proposed alternative vehicles and the result of both the inter and intra-modal shift.

In addition, the Final Report will include the five sub-studies defined above, namely:

- Estimate Relative Damage Risk Levels Due to Inelastic Deformation
- Fatigue Related Effects
- Posting Assessment
- Bridge Decks – Repair and Replacement Costs
- Preservation & Maintenance of Bridge Decks

## **Data Needs**

These are the databases to be used in the bridge project plan:

**NBIS Bridge Data:** – latest update (2012 data)

**WIM Data Format:** (MS Excel)

- Axle weights in 2000 lb. (1 Ton) Increments for Single, 2 Tons for Tandem & and 3 Tons for Tridem Configurations
- Count of Axles at each 1 Ton increment by Vehicle Class
- Configuration of each Truck Classification (axle loads and spacing)
- State summaries of all WIM sites in each of the States
- Quantity - A total of 12 normalized WIM Data sets representative of the cross section of highway types (scenarios) and regions.
- Truck weight histograms for one data set

**ABrR (VIRTIS) Bridge Models:**

- Format - Tested or proven and working models of real bridges in LRFR
- Pre-screened to allow for further screening, distributed over the regions and highway types
- Must be statistically representative of the 20 bridge types

**ABrR (VIRTIS) Trucks:** (for the Alternative Vehicles)

- Obtain (or if necessary create) the xml file for each of the alternative vehicles (trucks)
- Exact truck wheel spacing and load distribution needed

**Truck Traffic Data:** – Modal Shift

- In terms of percentages for each truck classification
- Modal shift results - tabulated by vehicle class for regions and for: 1) interstate, 2) primary arterials, or 3) other highway scenarios (other arterials or segments of the NHS and national truck network not on the interstate system nor on primary arterials)
- Modal shift results - for intra-modal and inter-modal shift

**Bridge Cost Data:**

- State Data:**
- FMIS cost data - State summary totals showing bridge portion, etc.
  - Regulations (Legal Load Charts)
  - Unit Costs for capital improvements to bridges (generally available on the internet)

**APPENDIX C – LOAD RATINGS AND ANALYSIS**

**TABLE OF CONTENTS**

**LOAD RATING RESULTS..... 188**

**Table STR-1:** Flexural Rating Result Statistics (GFB and Truss Bridges Not Included)188

**Table STR-2:** Shear Rating Result Statistics (GFB and Truss Bridges Not Included) . 188

**Figure STR-1:** Comparison of average flexural rating factors for different truck types.189

**Figure STR-2:** Comparison of average shear rating factors for different truck types... 189

**COMPARISONS OF BASELINE TRUCKS WITH OTHER VEHICLES**

**(FLEXURAL) ..... 190**

**Figure STR-3:** Comparison of flexural rating factors for all bridges  
         (compared with 3-S2) ..... 190

**Figure STR-4:** Comparison of flexural rating factors for all bridges  
         (compared with 2-S1-2) ..... 190

**Figure STR-5:** Comparison of flexural rating factors for IHS bridges  
         (compared with 3-S2) ..... 191

**Figure STR-6:** Comparison of flexural rating factors for IHS bridges  
         (compared with 2-S1-2) ..... 191

**Figure STR-7:** Comparison of flexural rating factors for other bridges on the NHS  
         (compared with 3-S2) ..... 192

**Figure STR-8:** Comparison of flexural rating factors for other bridges on the NHS  
         (compared with 2-S1-2) ..... 192

**COMPARISONS OF BASELINE TRUCKS WITH OTHER VEHICLES (SHEAR) ..... 193**

**Figure STR-9:** Comparison of shear rating factors for all bridges (compared with 3-S2)193

**Figure STR-10:** Comparison of shear rating factors for all bridges  
         (compared with 2-S1-2) ..... 193

**Figure STR-11:** Comparison of shear rating factors for IHS bridges  
         (compared with 3-S2) ..... 194

**Figure STR-12:** Comparison of shear rating factors for IHS bridges  
         (compared with 2-S1-2) ..... 194

**Figure STR-13:** Comparison of shear rating factors for other bridges on the NHS  
         (compared with 3-S2) ..... 195

**Figure STR-14:** Comparison of shear rating factors for other bridges on the NHS  
         (compared with 2-S1-2) ..... 195

**CUMULATIVE FREQUENCY DISTRIBUTION FUNCTIONS FOR RATING RESULTS (ALL BRIDGES)..... 196**



<b>Figure STR-15:</b> Cumulative distribution of flexural rating factors of all bridges (3-S2, Scenarios 1 - 3) .....	196
<b>Figure STR-16:</b> Cumulative distribution of flexural rating factors of all bridges (2-S1-2, Scenarios 4 - 6) .....	196
<b>Figure STR-17:</b> Cumulative distribution of shear rating factors of all bridges (3-S2, Scenarios 1 - 3) .....	197
<b>Figure STR-18:</b> Cumulative distribution of shear rating factors of all bridges (2-S1-2, Scenarios 4 - 6) .....	197
<b>CUMULATIVE FREQUENCY DISTRIBUTION FUNCTIONS FOR RATING RESULTS (INTERSTATE BRIDGES) .....</b>	
<b>Figure STR-19:</b> Cumulative distribution of flexural rating factors of IHS bridges (3-S2, Scenarios 1 - 3) .....	198
<b>Figure STR-20:</b> Cumulative distribution of flexural rating factors of IHS bridges (2-S1-2, Scenarios 4 - 6) .....	198
<b>Figure STR-21:</b> Cumulative distribution of shear rating factors of IHS bridges (3-S2, Scenarios 1 - 3) .....	199
<b>Figure STR-22:</b> Cumulative distribution of shear rating factors of IHS bridges (2-S1-2, Scenarios 4 - 6) .....	199
<b>CUMULATIVE FREQUENCY DISTRIBUTION FUNCTIONS FOR RATING RESULTS (OTHER BRIDGES ON THE NHS) .....</b>	
<b>Figure STR-23:</b> Cumulative distribution of flexural rating factors of other bridges on the NHS (3-S2, Scenarios 1-3).....	200
<b>Figure STR-24:</b> Cumulative distribution of flexural rating factors of other bridges on the NHS (2-S1-2, Scenarios 4 - 6) .....	200
<b>Figure STR-25:</b> Cumulative distribution of flexural rating factors of other bridges on the NHS (3-S2, Scenarios 1 - 3).....	201
<b>Figure STR-26:</b> Cumulative distribution of flexural rating factors of other bridges on the NHS (2-S1-2, Scenarios 4 - 6) .....	201
<b>DISTRIBUTION OF NORMALIZED RATING RESULTS (ALL BRIDGES) .....</b>	
<b>Figure STR-27:</b> Distribution of normalized flexural rating factors for all bridges (3-S2, Scenario #1, #2 and #3).....	202
<b>Figure STR-28:</b> Distribution of normalized flexural rating factors for all bridges (2-S1-2, Scenario #4, #5 and #6) .....	202
<b>Figure STR-29:</b> Distribution of normalized shear rating factors for all bridges (3-S2, Scenario #1, #2 and #3).....	203
<b>Figure STR-30:</b> Distribution of normalized shear rating factors for all bridges (2-S1-2, Scenario #4, #5 and #6) .....	203

<b>DISTRIBUTION OF NORMALIZED RATING RESULTS (IHS BRIDGES).....</b>	<b>204</b>
<b>Figure STR-31:</b> Distribution of normalized flexural rating factors for IHS Bridges (3-S2, Scenario #1, #2 and #3).....	204
<b>Figure STR-32:</b> Distribution of normalized flexural rating factors for IHS bridges (2-S1-2, Scenario #4, #5 and #6).....	204
<b>Figure STR-33:</b> Distribution of normalized shear rating factors for IHS Bridges (3-S2, Scenario #1, #2 and #3).....	205
<b>Figure STR-34:</b> Distribution of normalized shear rating factors for IHS bridges (2-S1-2, Scenario #4, #5 and #6).....	205
<b>DISTRIBUTION OF NORMALIZED RATING RESULTS (OTHER BRIDGES ON THE NHS).....</b>	<b>206</b>
<b>Figure STR-35:</b> Distribution of normalized flexural rating factors for other bridges on the NHS (3-S2, Scenario #1, #2 and #3).....	206
<b>Figure STR-36:</b> Distribution of normalized flexural rating factors for other bridges on the NHS (2-S1-2, Scenario #4, #5 and #6).....	206
<b>Figure STR-37:</b> Distribution of normalized shear rating factors for other bridges on the NHS (3-S2, Scenario #1, #2 and #3).....	207
<b>Figure STR-38:</b> Distribution of normalized shear rating factors for other bridges on the NHS (2-S1-2, Scenario #4, #5 and #6).....	207
<b>LOAD RATING RESULTS FOR BRIDGE TYPES.....</b>	<b>208</b>
<b>Table STR-3:</b> Flexural Rating Result Statistics for Reinforced Concrete Slabs.....	208
<b>Table STR-4:</b> Shear Rating Result Statistics for Reinforced Concrete Slabs.....	208
<b>Table STR-5:</b> Flexural Rating Result Statistics for Prestressed Concrete Beam/Girders, Simple Spans.....	209
<b>Table STR-6:</b> Shear Rating Result Statistics for Prestressed Concrete Beam/Girders, Simple Spans.....	209
<b>Table STR-7:</b> Flexural Rating Result Statistics for Prestressed Concrete Beam/Girders, Continuous Spans.....	210
<b>Table STR-8:</b> Shear Rating Result Statistics for Prestressed Concrete Beam/Girders, Continuous Spans.....	210
<b>Table STR-9:</b> Flexural Rating Result Statistics for Steel Beam/Girder, Simple Span (L < 100 ft.).....	211
<b>Table STR-10:</b> Shear Rating Result Statistics for Steel Beam/Girder, Simple Span (L < 100 ft.).....	211
<b>Table STR-11:</b> Flexural Rating Result Statistics for Steel Beam/Girder, Simple Span (L > 100 ft.).....	212

<b>Table STR-12: Shear Rating Result Statistics for Steel Beam/Girder, Simple Span (L &gt; 100 ft.)</b> .....	212
<b>Table STR-13: Flexural Rating Result Statistics for Steel Beam/Girder, Continuous Spans (L &lt; 100 ft.)</b> .....	213
<b>Table STR-14: Shear Rating Result Statistics for Steel Beam/Girder, Continuous Spans (L &lt; 100 ft.)</b> .....	213
<b>Table STR-15: Flexural Rating Result Statistics for Steel Beam/Girder, Continuous Spans (L &gt; 100 ft.)</b> .....	214
<b>Table STR-16: Shear Rating Result Statistics for Steel Beam/Girder, Continuous Spans (L &gt; 100 ft.)</b> .....	214
<b>Table STR-17: LFR Rating Factors for Girder Floorbeam Systems</b> .....	215
<b>Table STR-18: Flexural Rating Result Statistics for Reinforced Concrete Tee Beams</b>	215
<b>Table STR-19: Shear Rating Result Statistics for Reinforced Concrete Tee Beams</b> ....	216
<b>Table STR-20: Flexural Rating Result Statistics for Box Beams</b> .....	216
<b>Table STR-21: Shear Rating Result Statistics for Box Beams</b> .....	217
<b>Table STR-22: LFR Rating Factors for <i>Through Trusses</i></b> .....	217
<b>NORMALIZED LOAD RATING RESULTS FOR BRIDGE TYPES</b> .....	<b>218</b>
<b>Table STR-23: Normalized Flexural Rating Result Statistics for Reinforced Concrete Slabs</b> .....	218
<b>Table STR-24: Normalized Shear Rating Result Statistics for Reinforced Concrete Slabs</b> .....	218
<b>Table STR-25: Normalized Flexural Rating Result Statistics for Prestressed Concrete Beam/Girders, Simple Spans</b> .....	219
<b>Table STR-26: Normalized Shear Rating Result Statistics for Prestressed Concrete Beam/Girders, Simple Spans</b> .....	219
<b>Table STR-27: Normalized Flexural Rating Result Statistics for Prestressed Concrete Beam/Girders, Continuous Spans</b> .....	220
<b>Table STR-28: Normalized Shear Rating Result Statistics for Prestressed Concrete Beam/Girders, Continuous Spans</b> .....	220
<b>Table STR-29: Normalized Flexural Rating Result Statistics for Steel Beam/Girder, Simple Span (L &lt; 100 ft.)</b> .....	221
<b>Table STR-30: Normalized Shear Rating Result Statistics for Steel Beam/Girder, Simple Span (L &lt; 100 ft.)</b> .....	221
<b>Table STR-31: Normalized Flexural Rating Result Statistics for Steel Beam/Girder, Simple Span (L &gt; 100 ft.)</b> .....	222

<b>Table STR-32:</b> Normalized Shear Rating Result Statistics for Steel Beam/Girder, Simple Span ( $L > 100$ ft.) .....	222
<b>Table STR-33:</b> Normalized Flexural Rating Result Statistics for Steel Beam/Girder, Continuous Spans ( $L < 100$ ft.).....	223
<b>Table STR-34:</b> Normalized Shear Rating Result Statistics for Steel Beam/Girder, Continuous Spans ( $L < 100$ ft.).....	223
<b>Table STR-35:</b> Normalized Flexural Rating Result Statistics for Steel Beam/Girder, Continuous Spans ( $L > 100$ ft.).....	224
<b>Table STR-36:</b> Normalized Shear Rating Result Statistics for Steel Beam/Girder, Continuous Spans ( $L > 100$ ft.).....	224
<b>Table STR-37:</b> Normalized LFR Rating Factors for Girder Floorbeam Systems.....	225
<b>Table STR-38:</b> Normalized Flexural Rating Result Statistics for Reinforced Concrete Tee Beams.....	225
<b>Table STR-39:</b> Normalized Shear Rating Result Statistics for Reinforced Concrete Tee Beams.....	226
<b>Table STR-40:</b> Normalized Flexural Rating Result Statistics for Box Beams .....	226
<b>Table STR-41:</b> Normalized Shear Rating Result Statistics for Box Beams.....	227
<b>Table STR-42:</b> Normalized LFR Rating Factors for <i>Through Trusses</i> .....	227
<b>POSTING ANALYSIS</b> .....	<b>228</b>
<b>Table STR-43:</b> Bridges with $RF < 1.0$ Sorted by Bridge Type .....	228
<b>Table STR-44:</b> Bridges with $RF < 1.0$ Sorted by Span Length.....	231
<b>Table STR-45:</b> Bridges with $RF < 1.0$ Sorted by Year Built .....	234
<b>Table STR-46:</b> Posting Projections .....	237

**LOAD RATING RESULTS**

**Table STR-1: Flexural Rating Result Statistics (GFB and Truss Bridges Not Included)**

		3-S2	Scenario #1	Scenario #2	Scenario #3	2-S1-2	Scenario #4	Scenario #5	Scenario #6
<b>ALL BRIDGES</b>	<b>AVERAGE</b>	2.782	2.526	2.387	2.214	3.279	2.805	2.851	2.202
	<b>MAX</b>	8.429	7.725	7.526	6.969	8.350	7.465	7.698	5.871
	<b>MIN</b>	0.715	0.649	0.589	0.545	0.817	0.751	0.684	0.554
	<b>TOTAL #</b>	463	463	463	463	463	463	463	463
	<b># RF &lt; 1.0</b>	<b>12</b>	<b>16</b>	<b>25</b>	<b>33</b>	<b>2</b>	<b>12</b>	<b>3</b>	<b>22</b>
<b>IHS BRIDGES</b>	<b>AVERAGE</b>	2.915	2.645	2.515	2.335	3.361	2.917	2.870	2.235
	<b>MAX</b>	8.337	7.598	7.461	6.943	8.350	7.430	7.023	5.641
	<b>MIN</b>	0.715	0.649	0.631	0.583	0.817	0.751	0.684	0.554
	<b>TOTAL #</b>	150	150	150	150	150	150	150	150
	<b># RF &lt; 1.0</b>	<b>4</b>	<b>4</b>	<b>4</b>	<b>5</b>	<b>2</b>	<b>4</b>	<b>2</b>	<b>7</b>
<b>OTHER BRIDGES ON THE NHS</b>	<b>AVERAGE</b>	2.718	2.469	2.325	2.156	3.239	2.752	2.842	2.186
	<b>MAX</b>	8.429	7.725	7.526	6.969	8.329	7.465	7.698	5.871
	<b>MIN</b>	0.748	0.675	0.589	0.545	1.068	0.824	0.971	0.750
	<b>TOTAL #</b>	313	313	313	313	313	313	313	313
	<b># RF &lt; 1.0</b>	<b>8</b>	<b>12</b>	<b>21</b>	<b>28</b>	<b>0</b>	<b>8</b>	<b>1</b>	<b>15</b>

**Table STR-2: Shear Rating Result Statistics (GFB and Truss Bridges Not Included)**

		3-S2	Scenario #1	Scenario #2	Scenario #3	2-S1-2	Scenario #4	Scenario #5	Scenario #6
<b>ALL BRIDGES</b>	<b>AVERAGE</b>	3.816	3.442	3.228	2.984	4.591	3.862	4.094	3.133
	<b>MAX</b>	19.86	18.06	17.38	16.06	28.07	22.55	26.26	20.10
	<b>MIN</b>	0.707	0.626	0.591	0.541	0.806	0.728	0.660	0.516
	<b>TOTAL #</b>	463	463	463	463	463	463	463	463
	<b># RF &lt; 1.0</b>	<b>4</b>	<b>7</b>	<b>8</b>	<b>10</b>	<b>1</b>	<b>2</b>	<b>3</b>	<b>8</b>
<b>IHS BRIDGES</b>	<b>AVERAGE</b>	3.679	3.319	3.106	2.876	4.330	3.697	3.806	2.911
	<b>MAX</b>	13.58	12.27	11.73	10.99	15.40	13.70	13.12	9.35
	<b>MIN</b>	0.997	0.896	0.837	0.781	1.136	1.014	0.922	0.723
	<b>TOTAL #</b>	150	150	150	150	150	150	150	150
	<b># RF &lt; 1.0</b>	<b>1</b>	<b>1</b>	<b>1</b>	<b>2</b>	<b>0</b>	<b>0</b>	<b>1</b>	<b>3</b>
<b>OTHER BRIDGES ON THE NHS</b>	<b>AVERAGE</b>	3.881	3.501	3.286	3.036	4.715	3.941	4.232	3.240
	<b>MAX</b>	19.86	18.06	17.38	16.06	28.07	22.55	26.26	20.10
	<b>MIN</b>	0.707	0.626	0.591	0.541	0.806	0.728	0.660	0.516
	<b>TOTAL #</b>	313	313	313	313	313	313	313	313
	<b># RF &lt; 1.0</b>	<b>3</b>	<b>6</b>	<b>7</b>	<b>8</b>	<b>1</b>	<b>2</b>	<b>2</b>	<b>5</b>

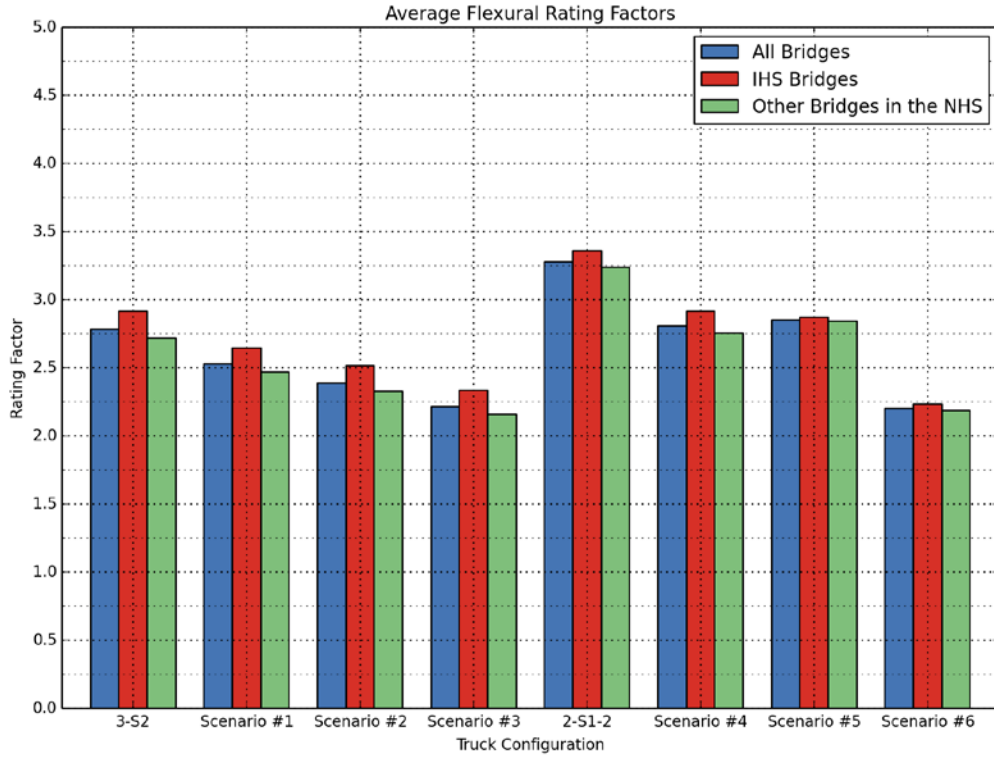


Figure STR-1: Comparison of average flexural rating factors for different truck types.

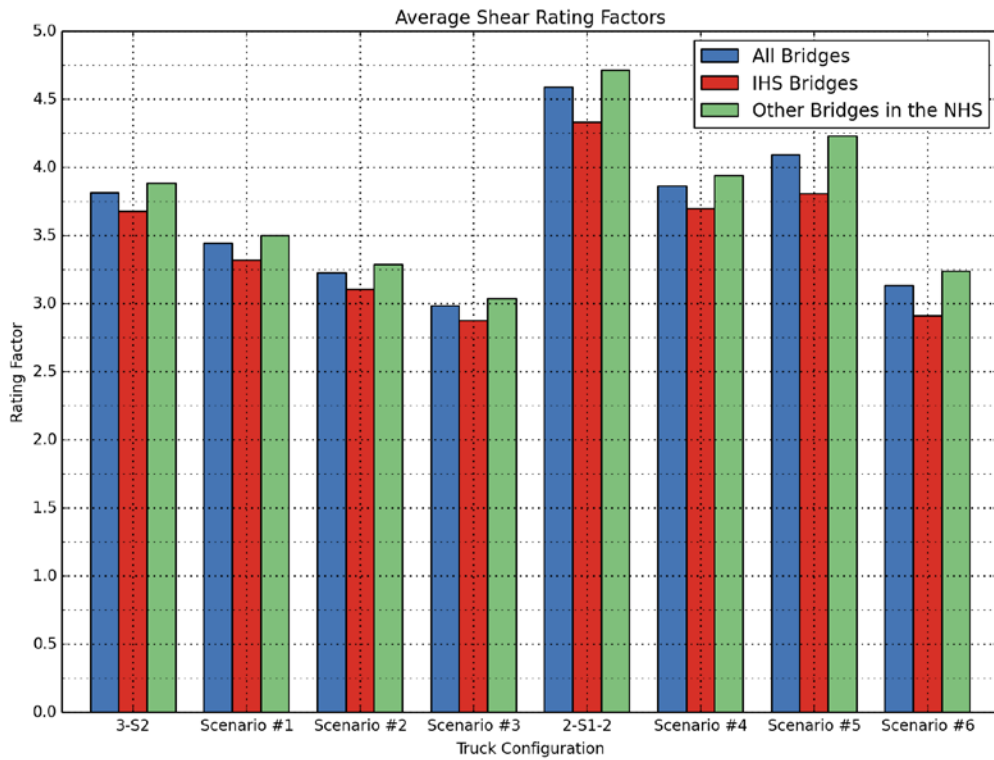
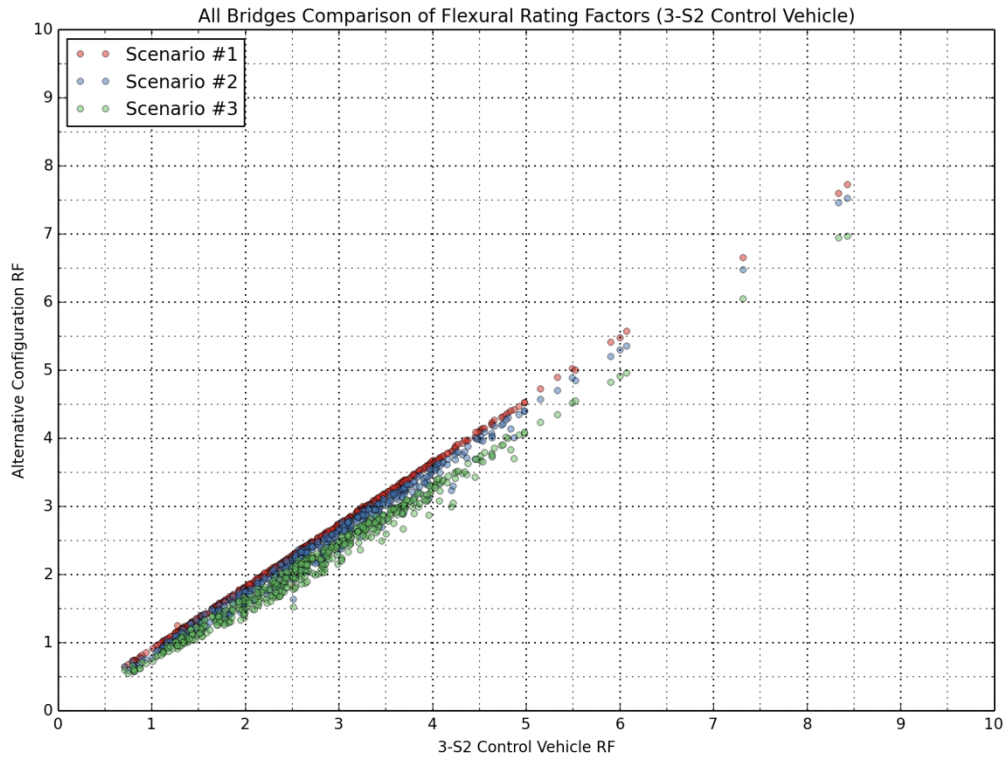
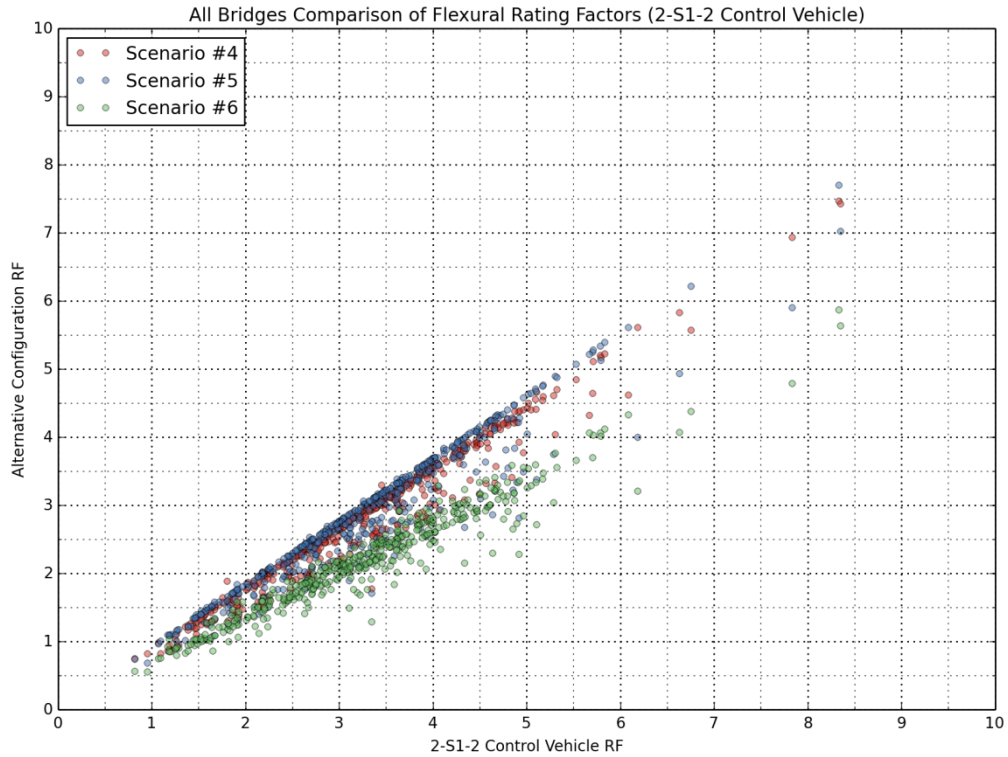


Figure STR-2: Comparison of average shear rating factors for different truck types.

**COMPARISONS OF BASELINE TRUCKS WITH OTHER VEHICLES (FLEXURAL)**



**Figure STR-3: Comparison of flexural rating factors for all bridges (compared with 3-S2)**



**Figure STR-4: Comparison of flexural rating factors for all bridges (compared with 2-S1-2)**

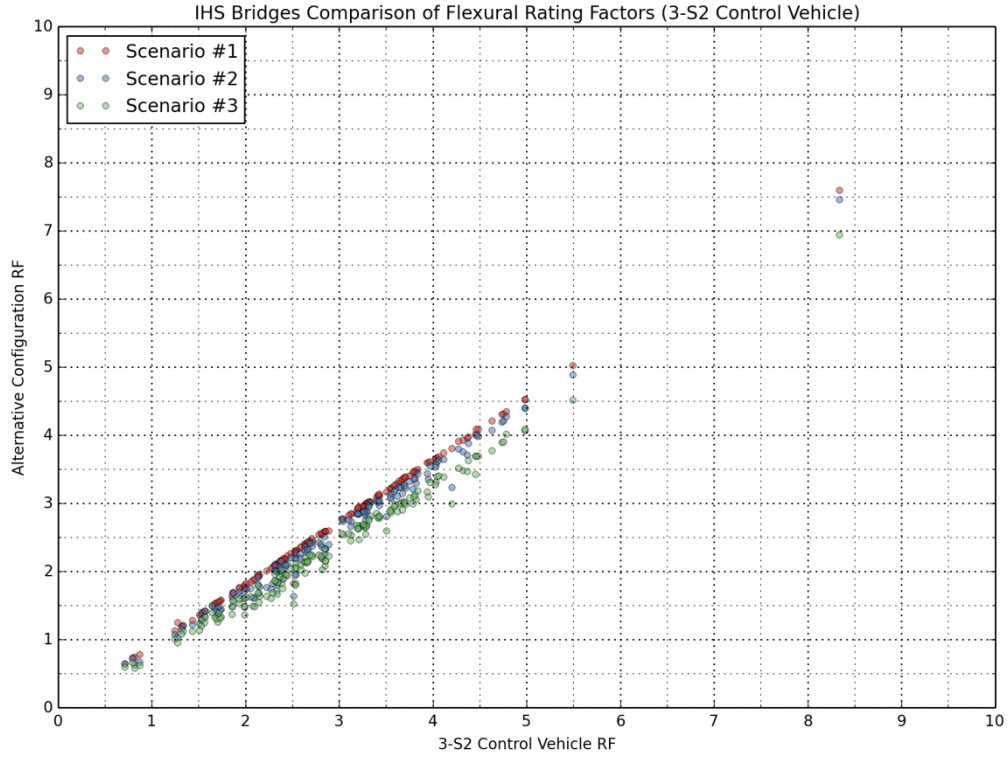


Figure STR-5: Comparison of flexural rating factors for IHS bridges (compared with 3-S2)

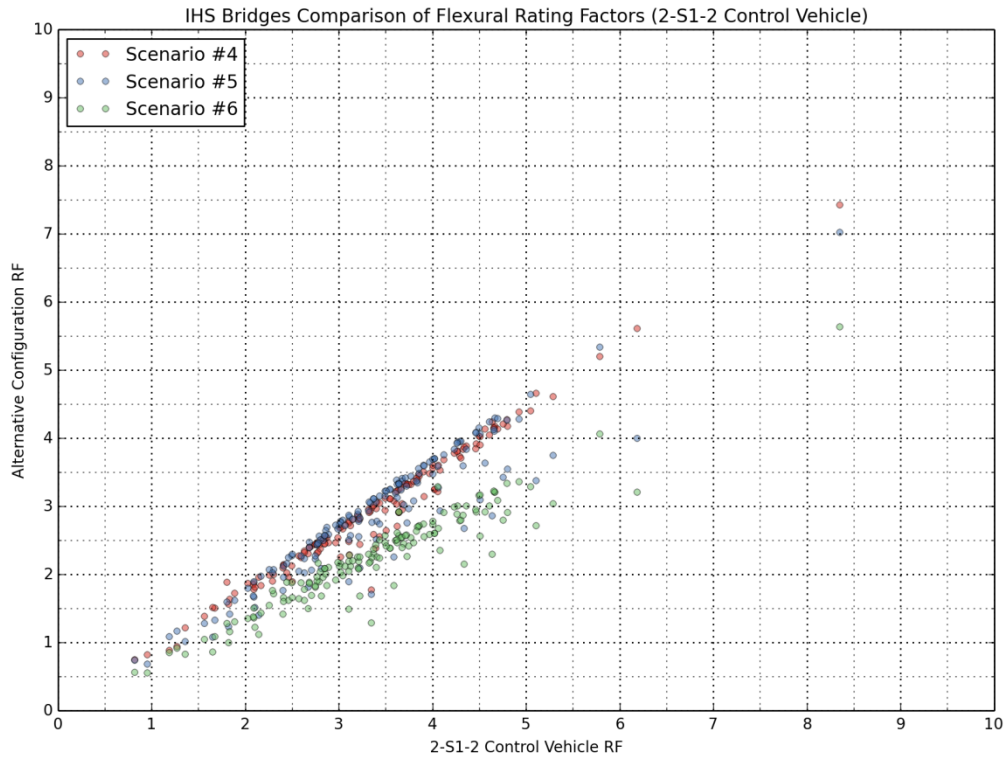
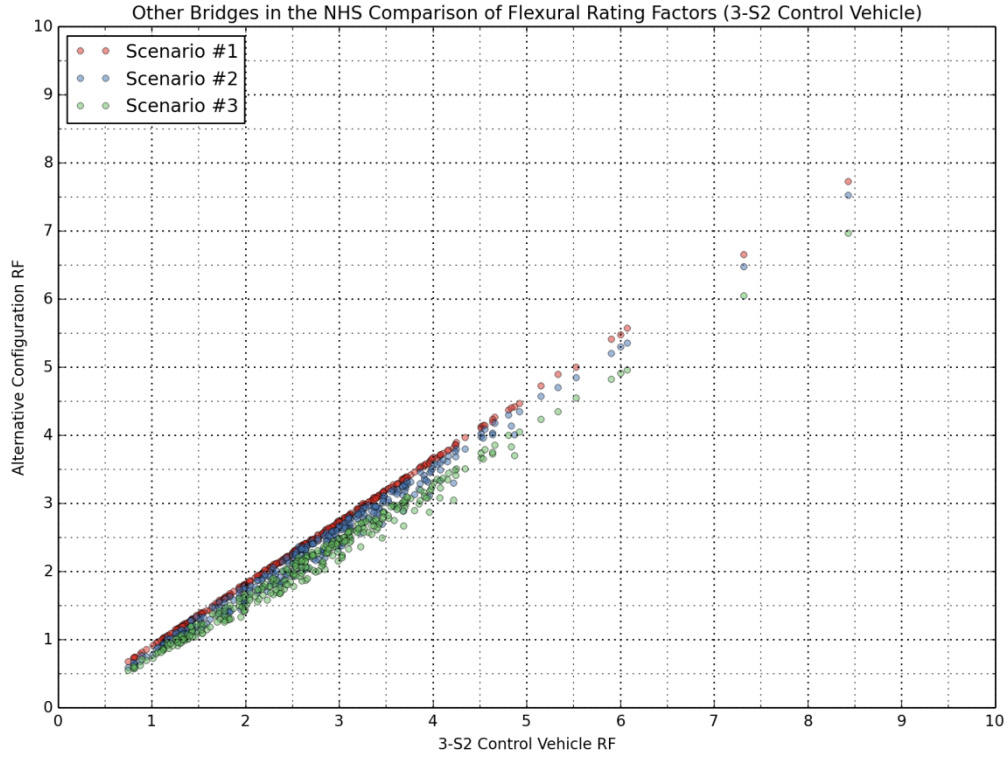
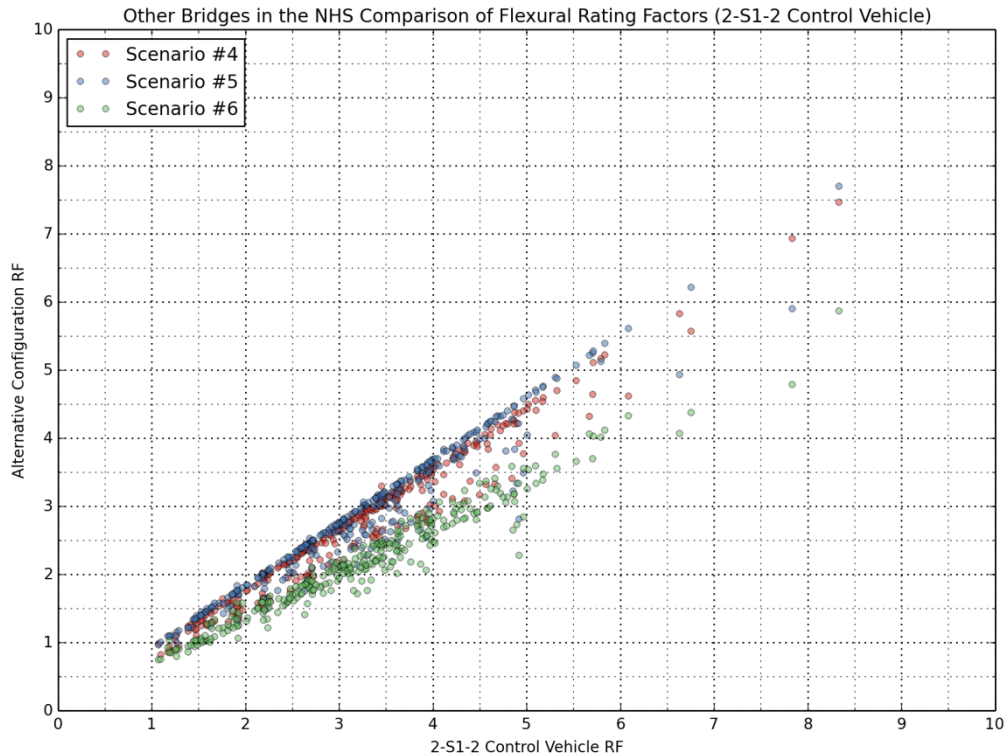


Figure STR-6: Comparison of flexural rating factors for IHS bridges (compared with 2-S1-2)



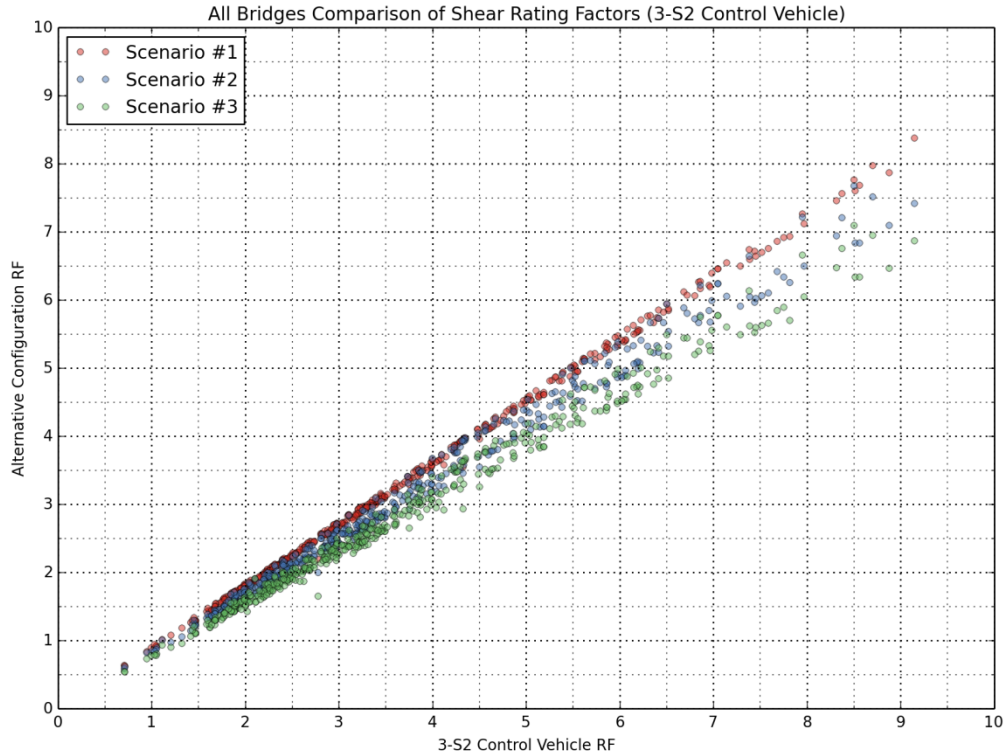


**Figure STR-7: Comparison of flexural rating factors for other bridges on the NHS (compared with 3-S2)**

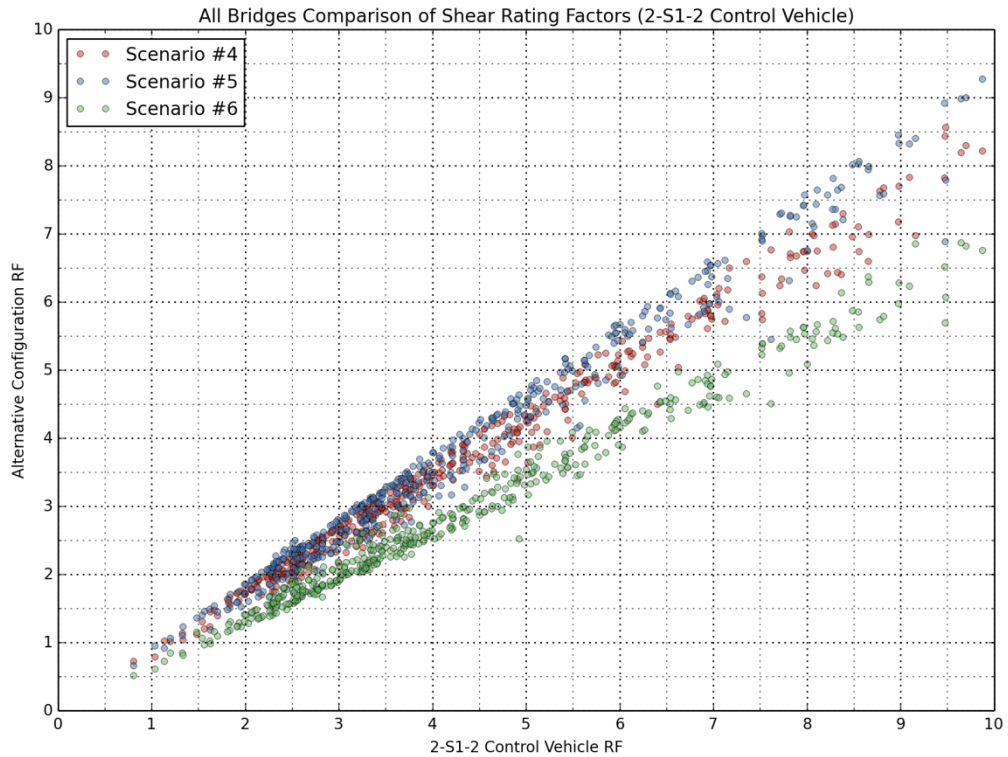


**Figure STR-8: Comparison of flexural rating factors for other bridges on the NHS (compared with 2-S1-2)**

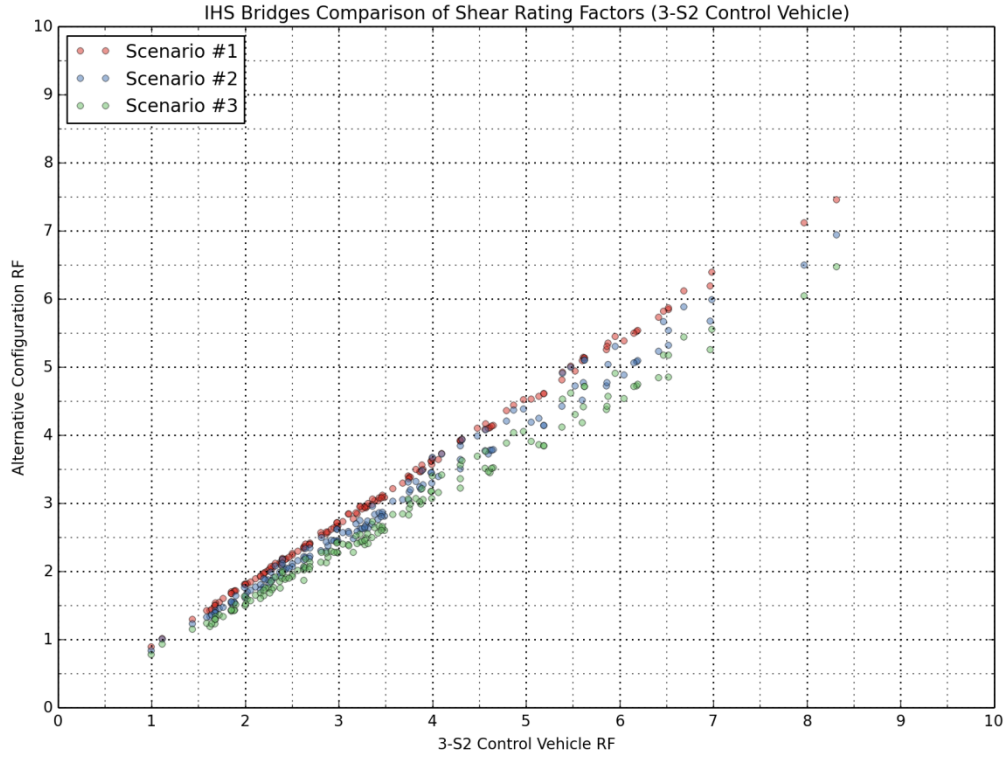
**COMPARISONS OF BASELINE TRUCKS WITH OTHER VEHICLES (SHEAR)**



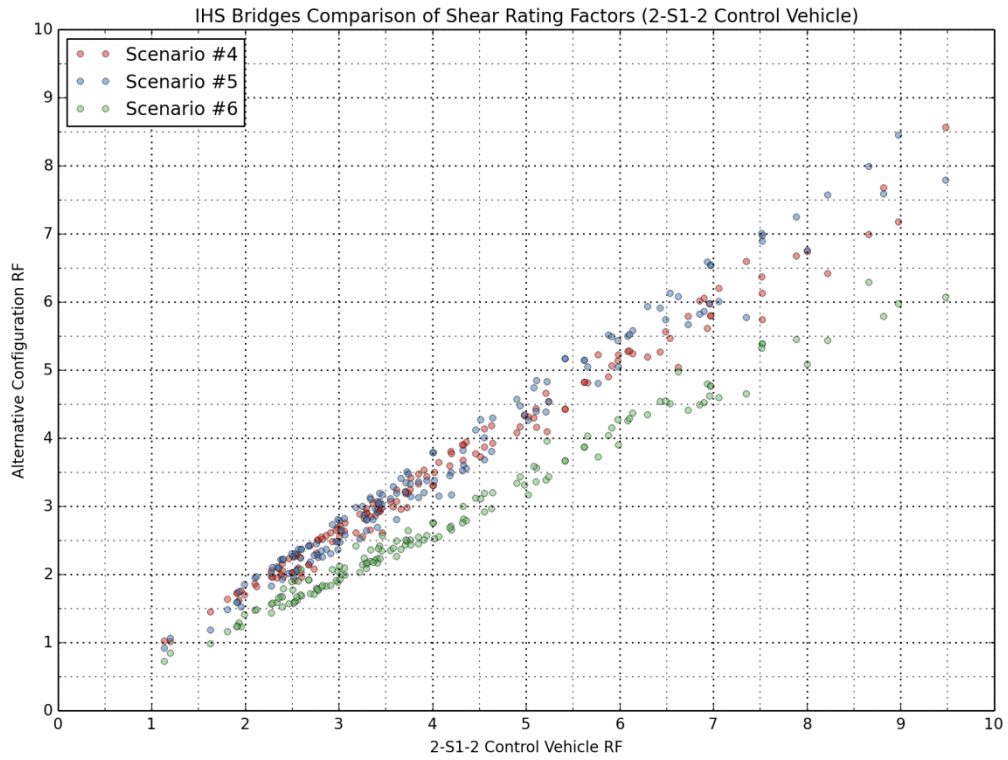
**Figure STR-9: Comparison of shear rating factors for all bridges (compared with 3-S2)**



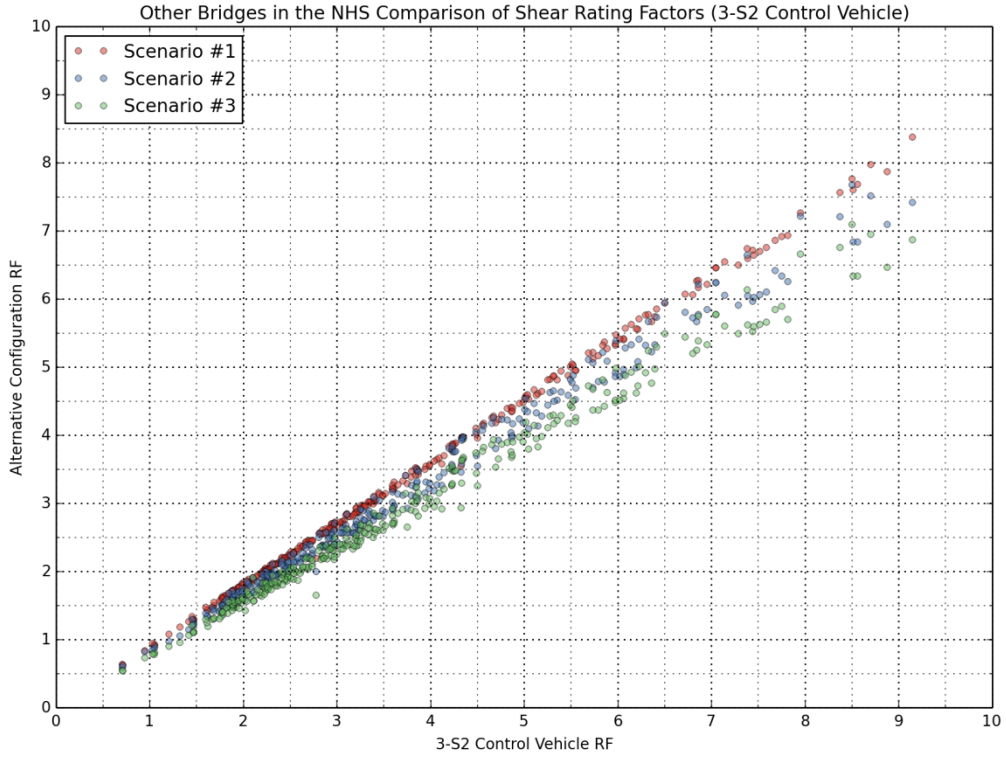
**Figure STR-10: Comparison of shear rating factors for all bridges (compared with 2-S1-2)**



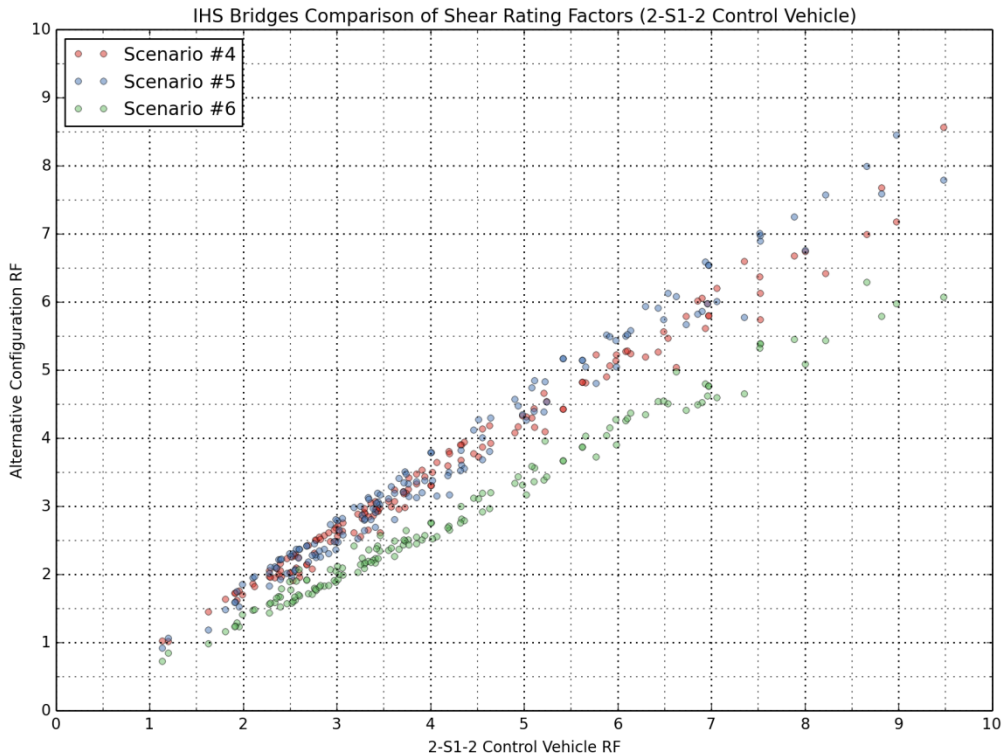
**Figure STR-11: Comparison of shear rating factors for IHS bridges (compared with 3-S2)**



**Figure STR-12: Comparison of shear rating factors for IHS bridges (compared with 2-S1-2)**



**Figure STR-13: Comparison of shear rating factors for other bridges on the NHS (compared with 3-S2)**



**Figure STR-14: Comparison of shear rating factors for other bridges on the NHS (compared with 2-S1-2)**

**CUMULATIVE FREQUENCY DISTRIBUTION FUNCTIONS FOR RATING RESULTS  
(ALL BRIDGES)**

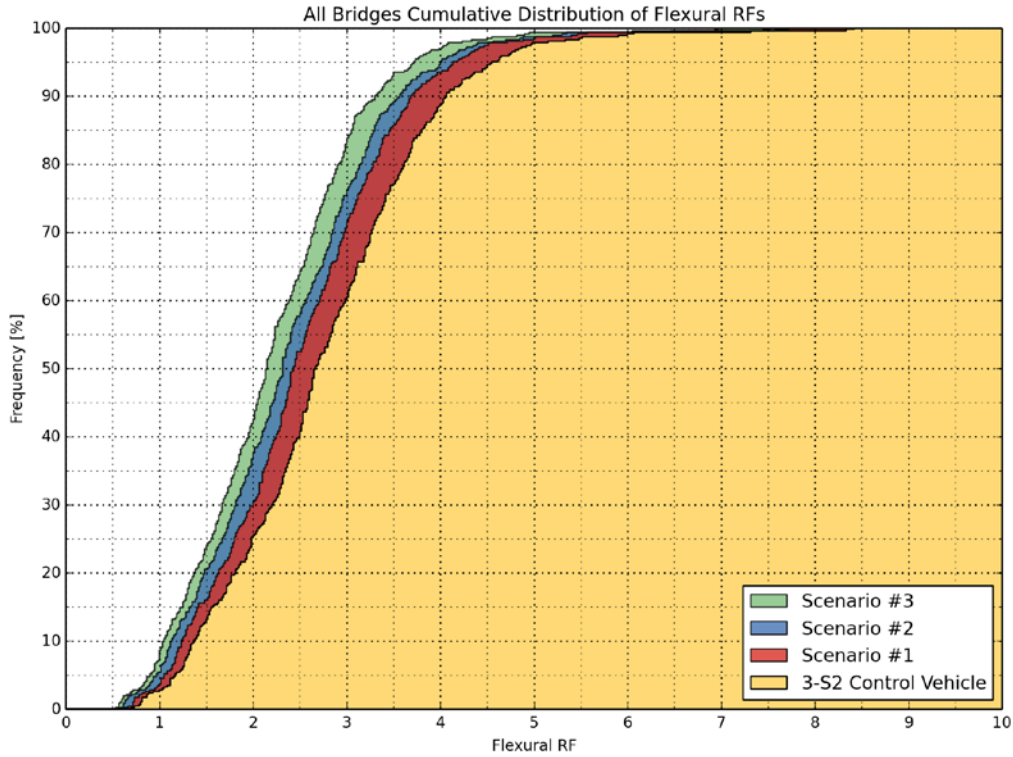


Figure STR-15: Cumulative distribution of flexural rating factors of all bridges (3-S2, Scenarios 1-3).

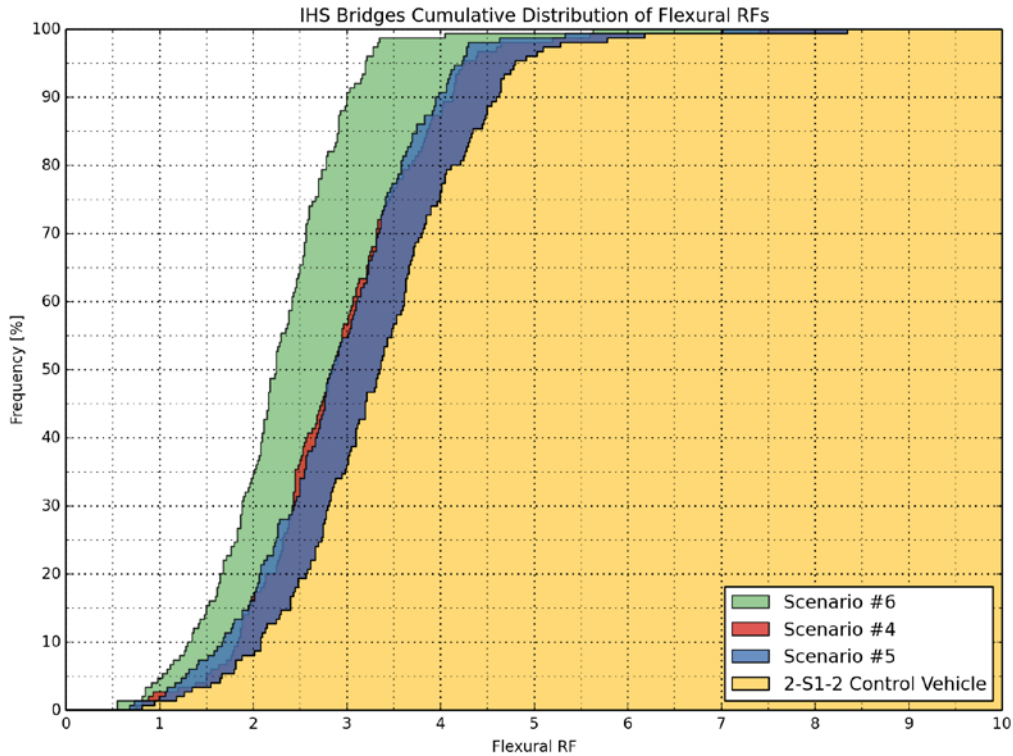
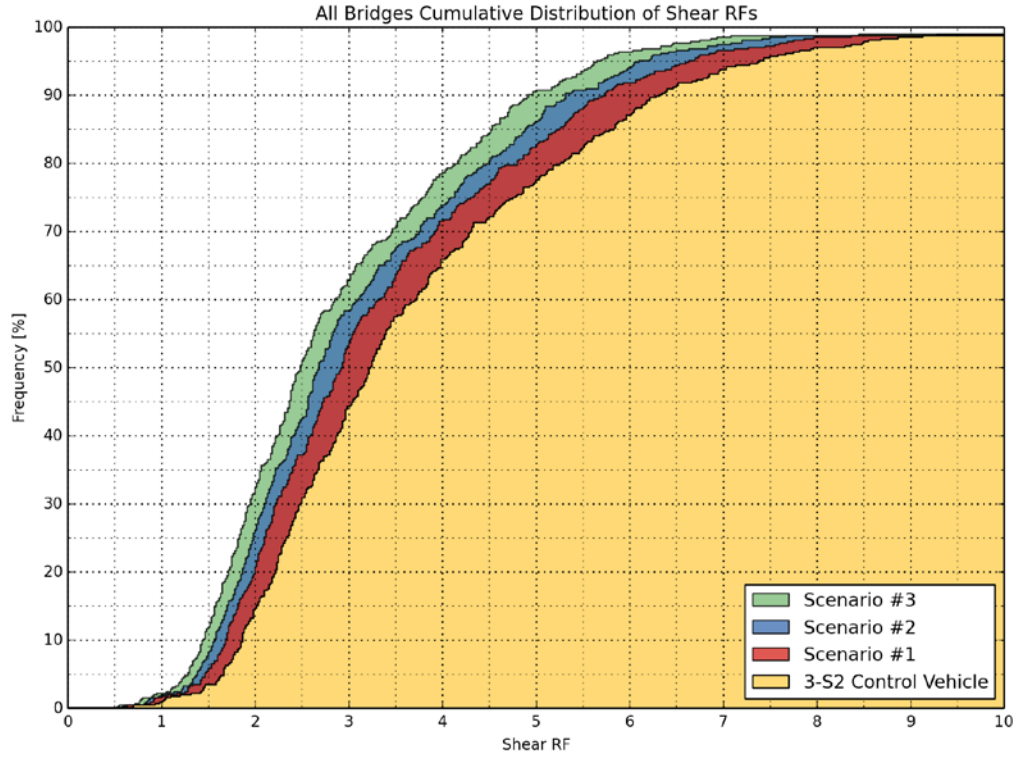
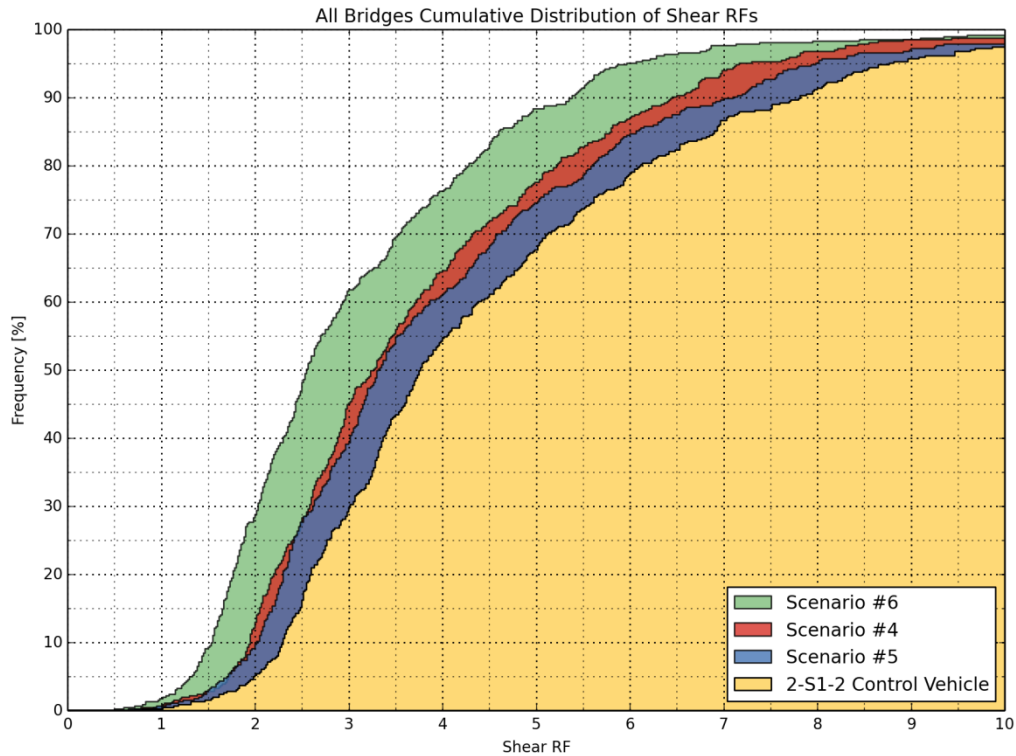


Figure STR-16: Cumulative distribution of flexural rating factors of all bridges (2-S1-2, Scenarios 4-6)

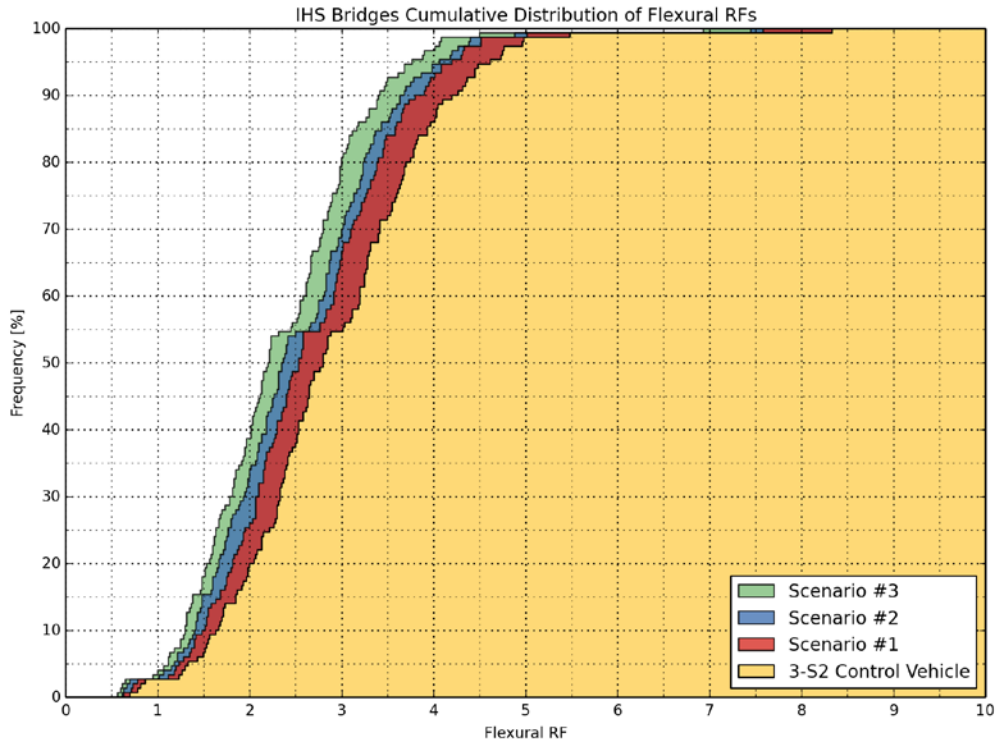


**Figure STR-17: Cumulative distribution of shear rating factors of all bridges (3-S2, Scenarios 1 - 3)**

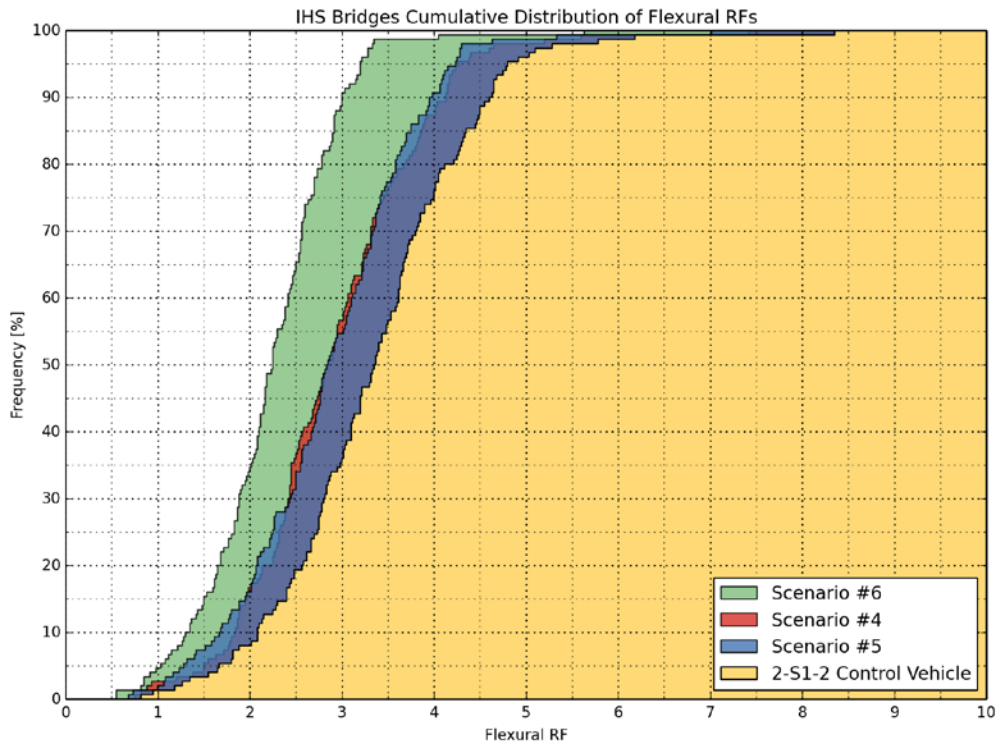


**Figure STR-18: Cumulative distribution of shear rating factors of all bridges (2-S1-2, Scenarios 4 - 6).**

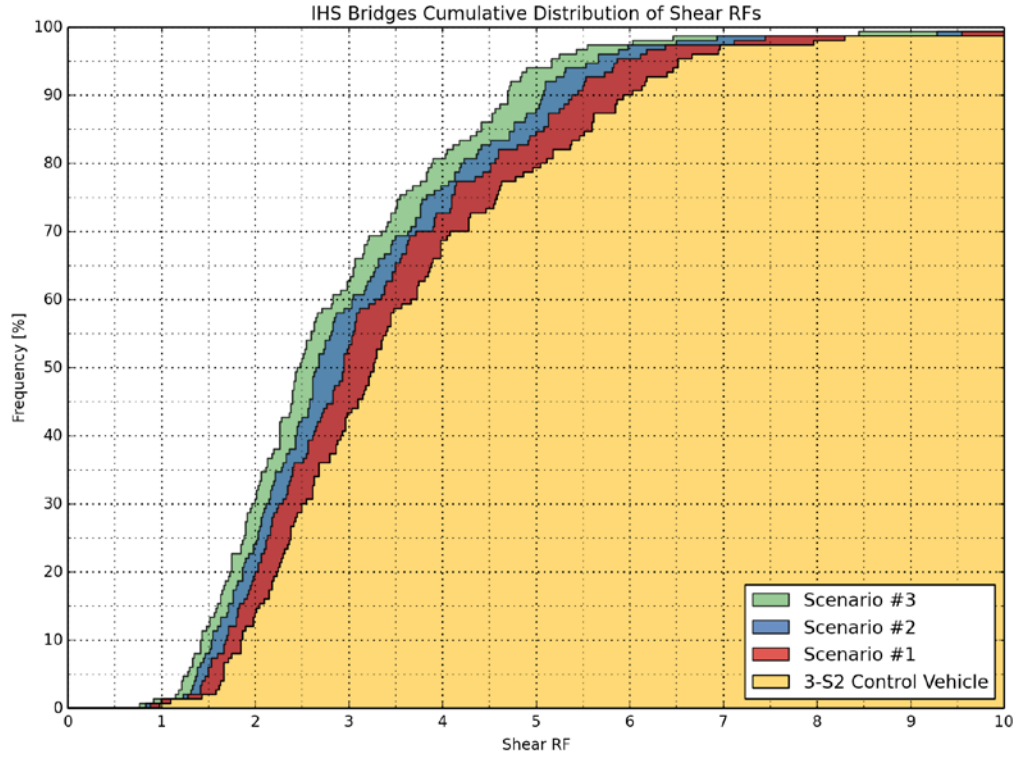
**CUMULATIVE FREQUENCY DISTRIBUTION FUNCTIONS FOR RATING RESULTS  
(INTERSTATE BRIDGES)**



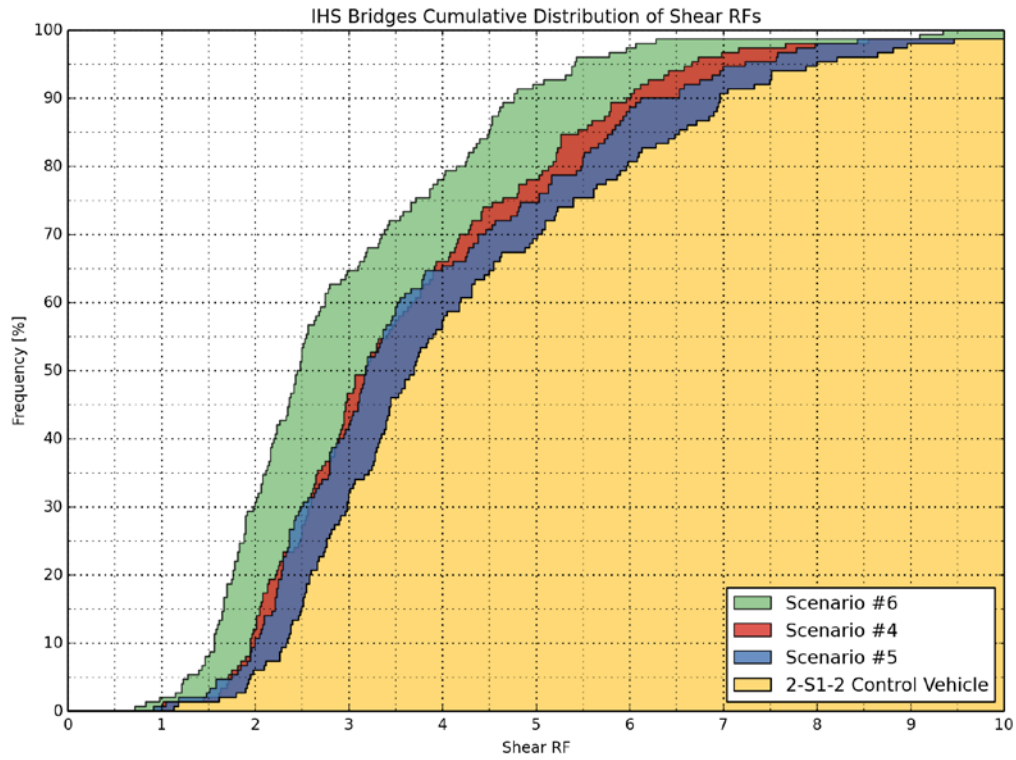
**Figure STR-19: Cumulative distribution of flexural rating factors of IHS bridges (3-S2, Scenarios 1-3)**



**Figure STR-20: Cumulative distribution of flexural rating factors of IHS bridges (2-S1-2, Scenarios 4-6)**



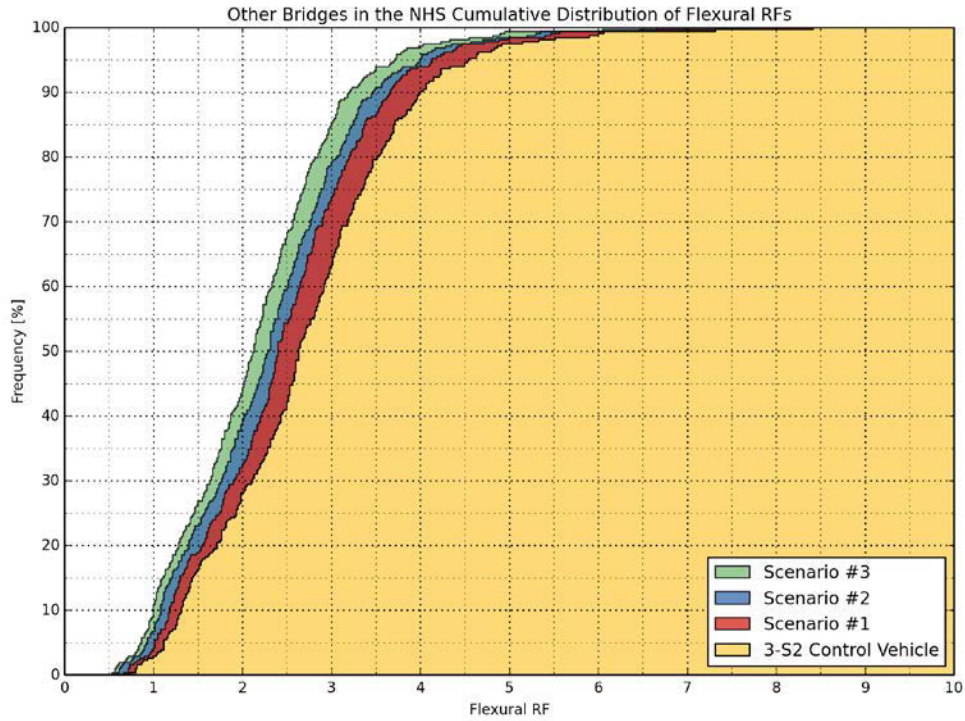
**Figure STR-21: Cumulative distribution of shear rating factors of IHS bridges (3-S2, Scenarios 1 - 3)**



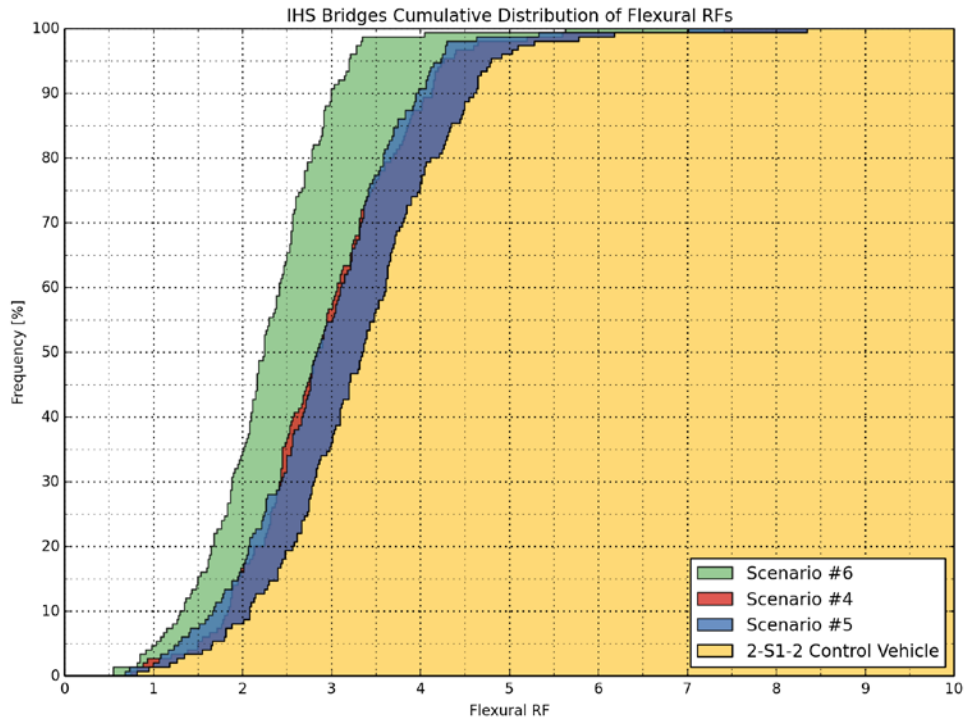
**Figure STR-22: Cumulative distribution of shear rating factors of IHS bridges (2-S1-2, Scenarios 4 - 6)**



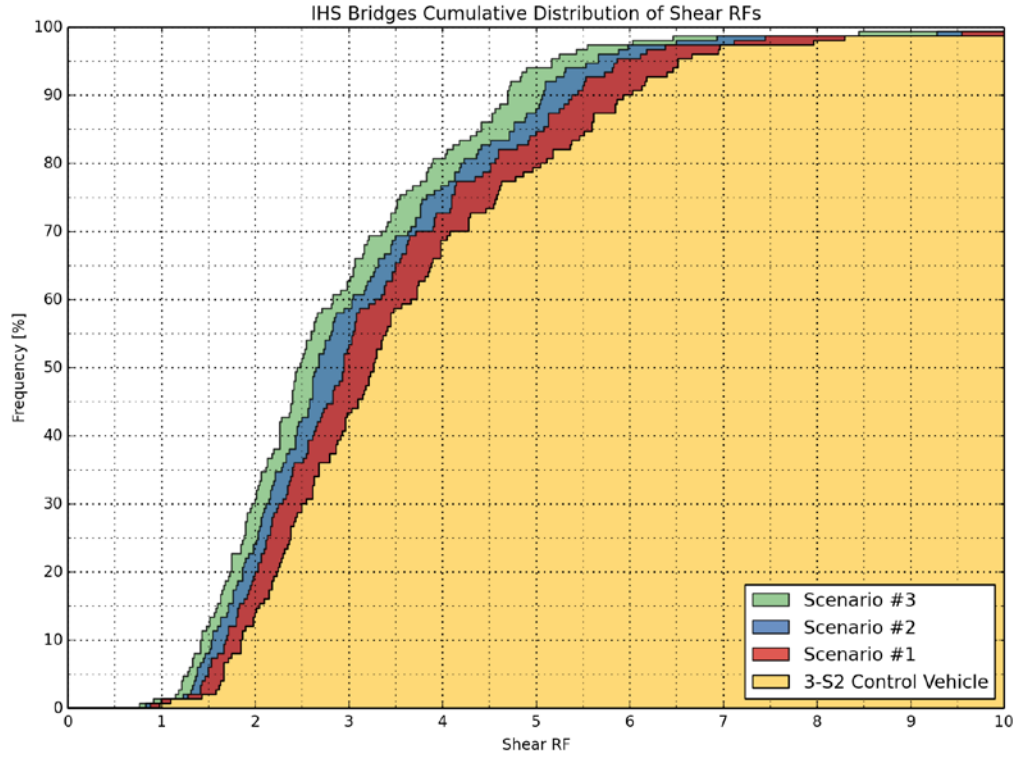
**CUMULATIVE FREQUENCY DISTRIBUTION FUNCTIONS FOR RATING RESULTS  
(OTHER BRIDGES ON THE NHS)**



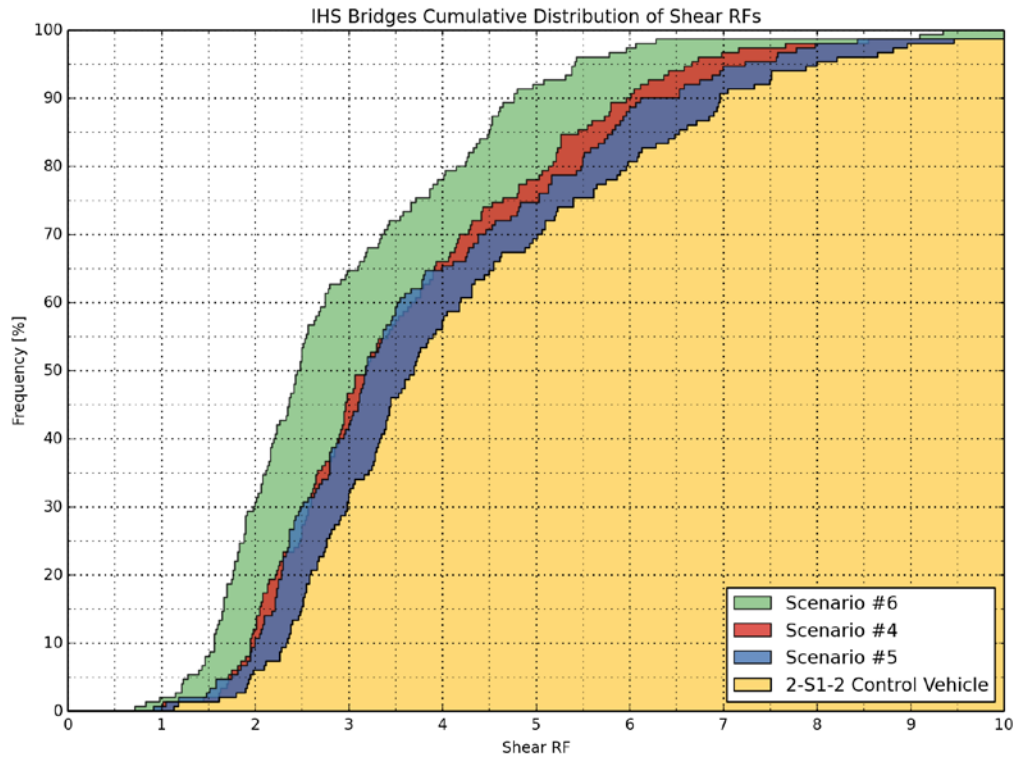
**Figure STR-23: Cumulative distribution of flexural rating factors of other bridges on the NHS (3-S2, Scenarios 1-3)**



**Figure STR-24: Cumulative distribution of flexural rating factors of other bridges on the NHS (2-S1-2, Scenarios 4 - 6)**

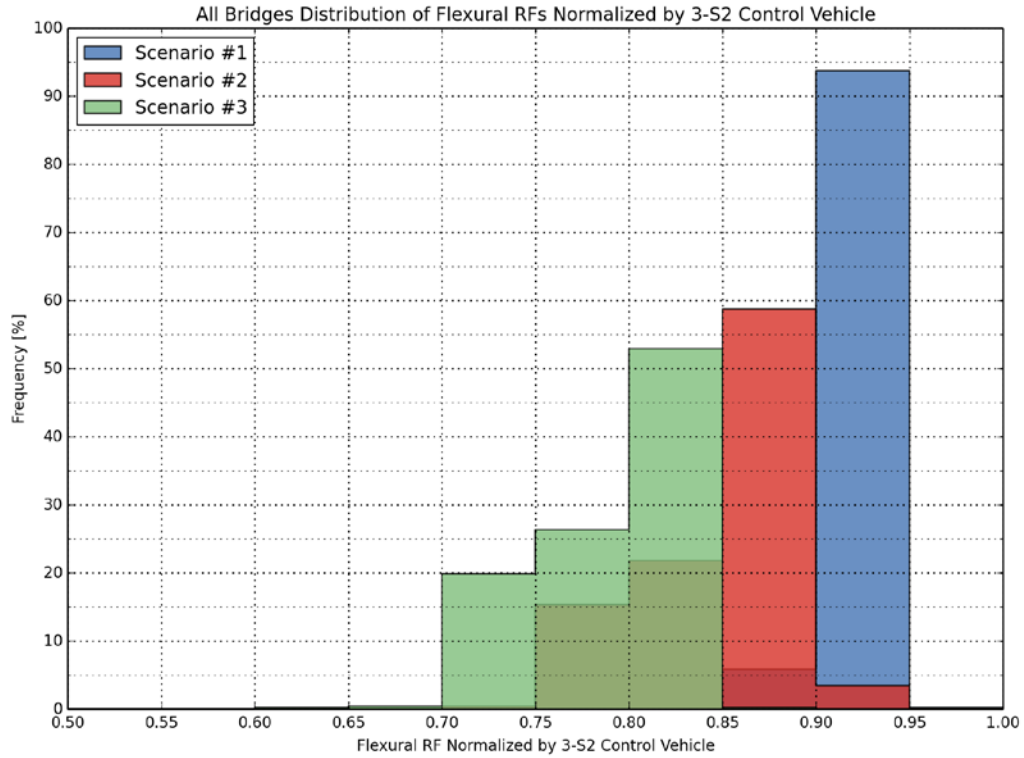


**Figure STR-25: Cumulative distribution of flexural rating factors of other bridges on the NHS (3-S2, Scenarios 1 - 3)**

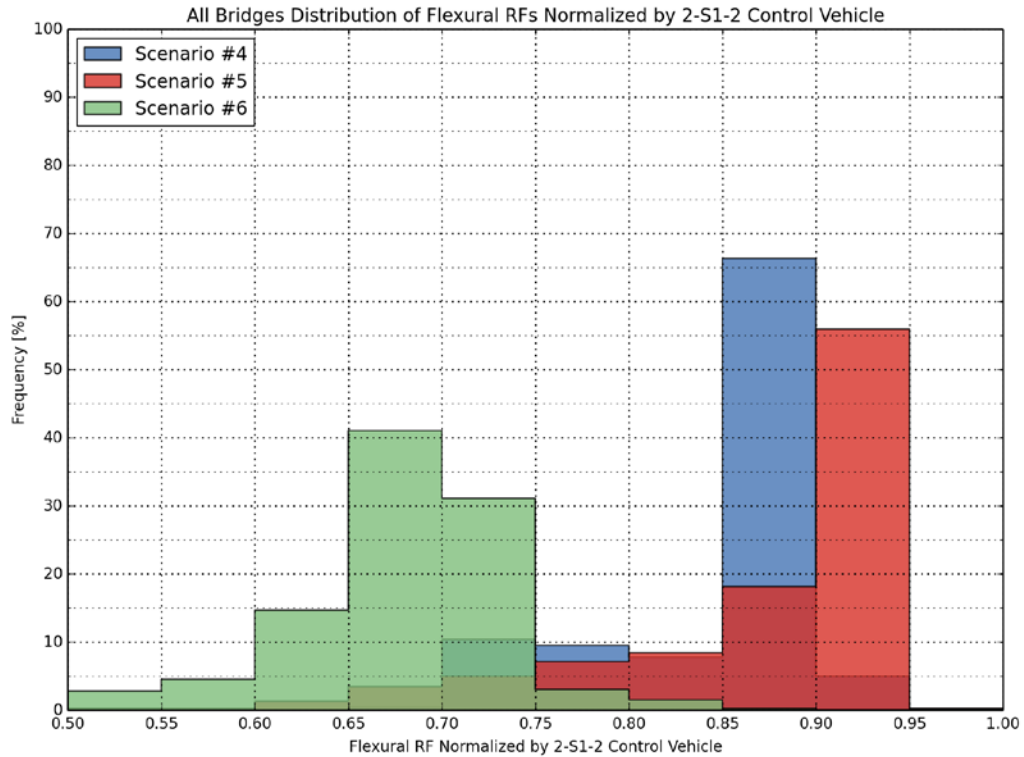


**Figure STR-26: Cumulative distribution of flexural rating factors of other bridges on the NHS (2-S1-2, Scenarios 4 - 6)**

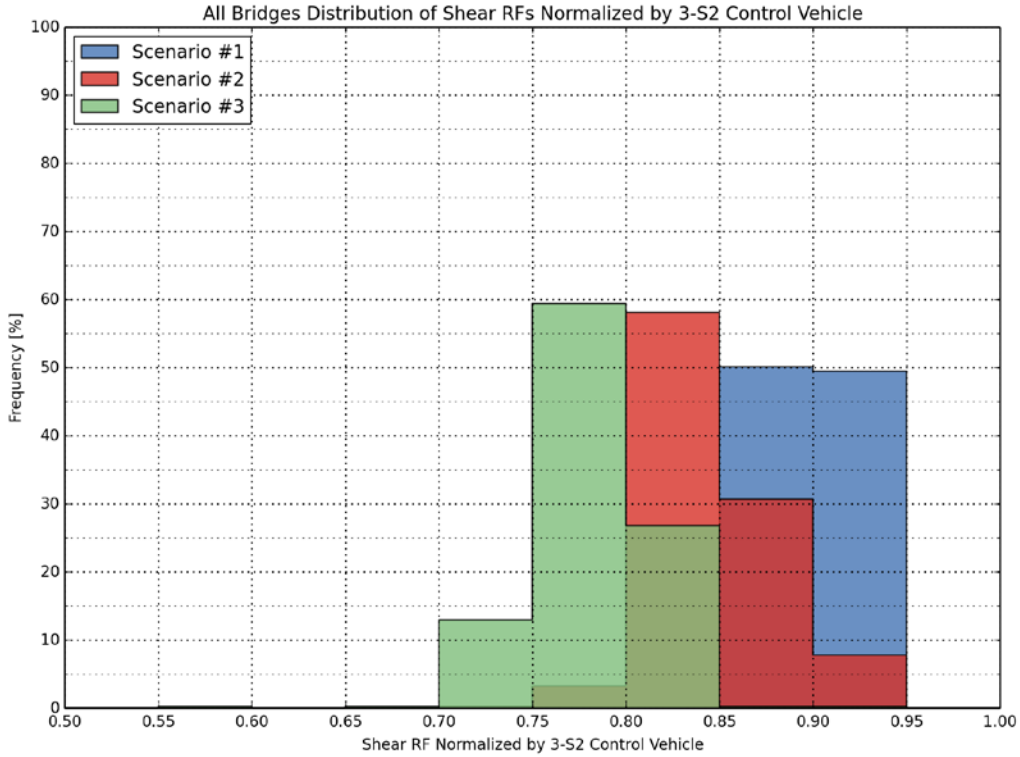
**DISTRIBUTION OF NORMALIZED RATING RESULTS (ALL BRIDGES)**



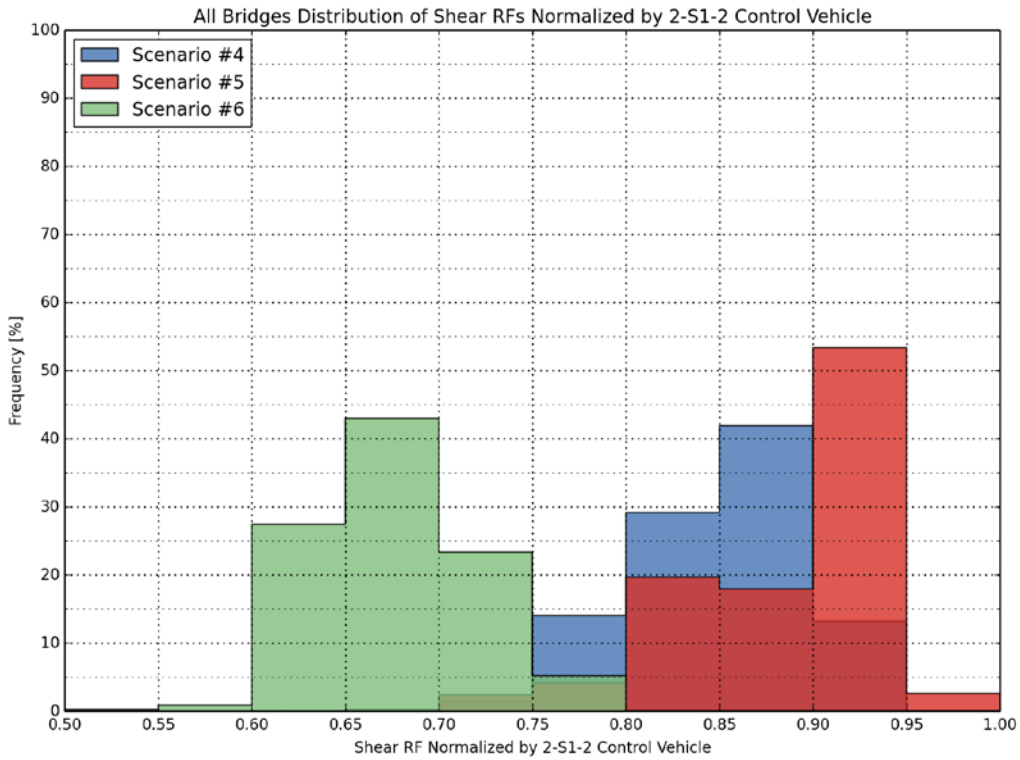
**Figure STR-27: Distribution of normalized flexural rating factors for all bridges (3-S2, Scenario #1, #2 and #3)**



**Figure STR-28: Distribution of normalized flexural rating factors for all bridges (2-S1-2, Scenario #4, #5 and #6)**

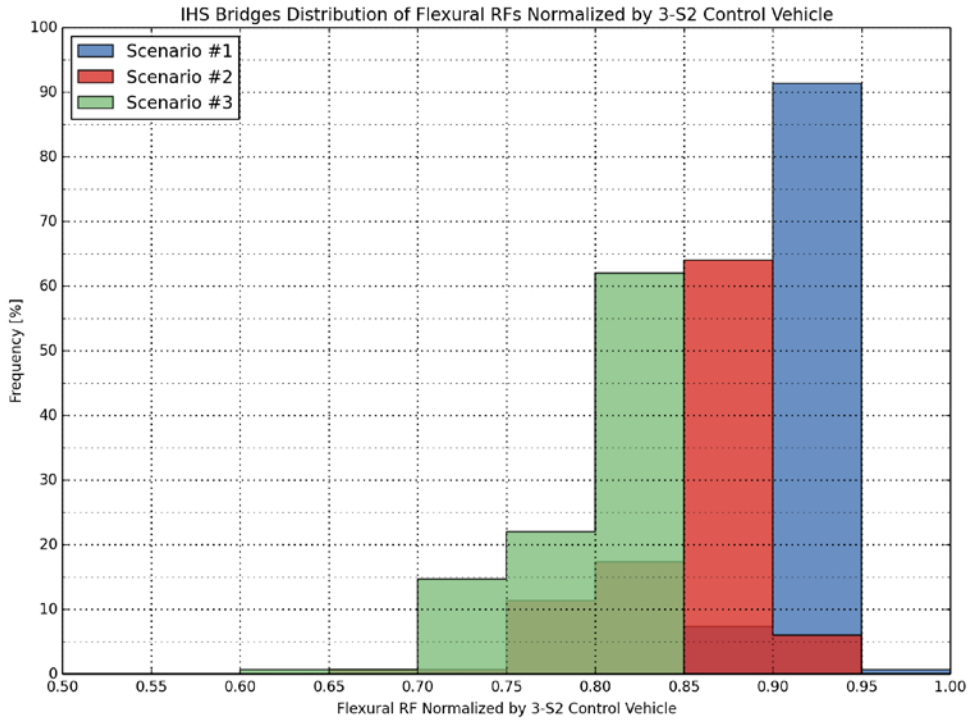


**Figure STR-29: Distribution of normalized shear rating factors for all bridges (3-S2, Scenario #1, #2 and #3)**

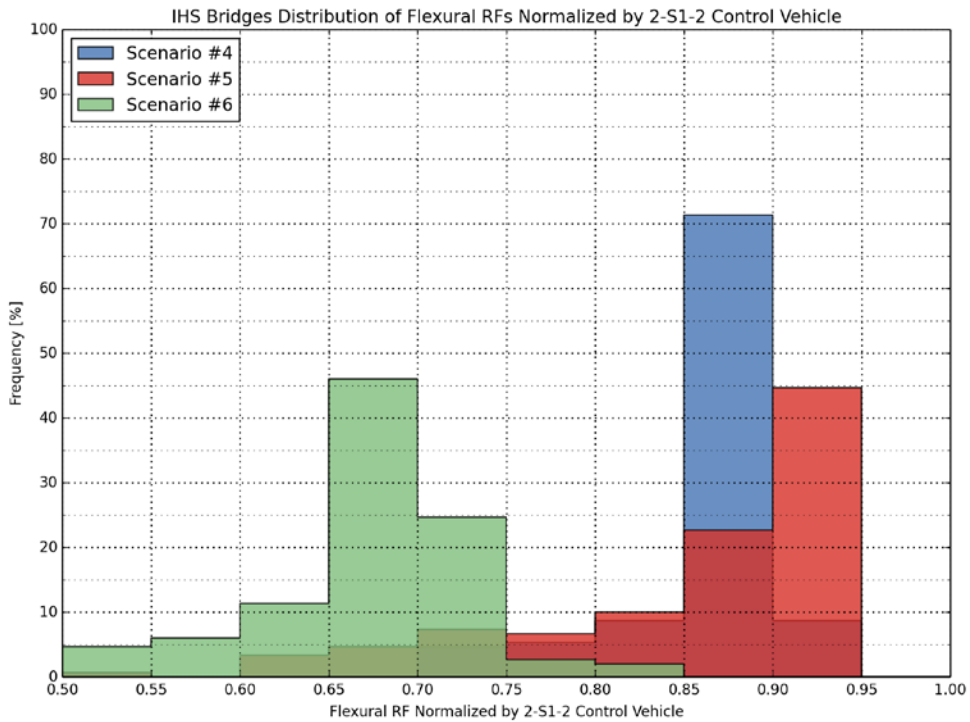


**Figure STR-30: Distribution of normalized shear rating factors for all bridges (2-S1-2, Scenario #4, #5 and #6)**

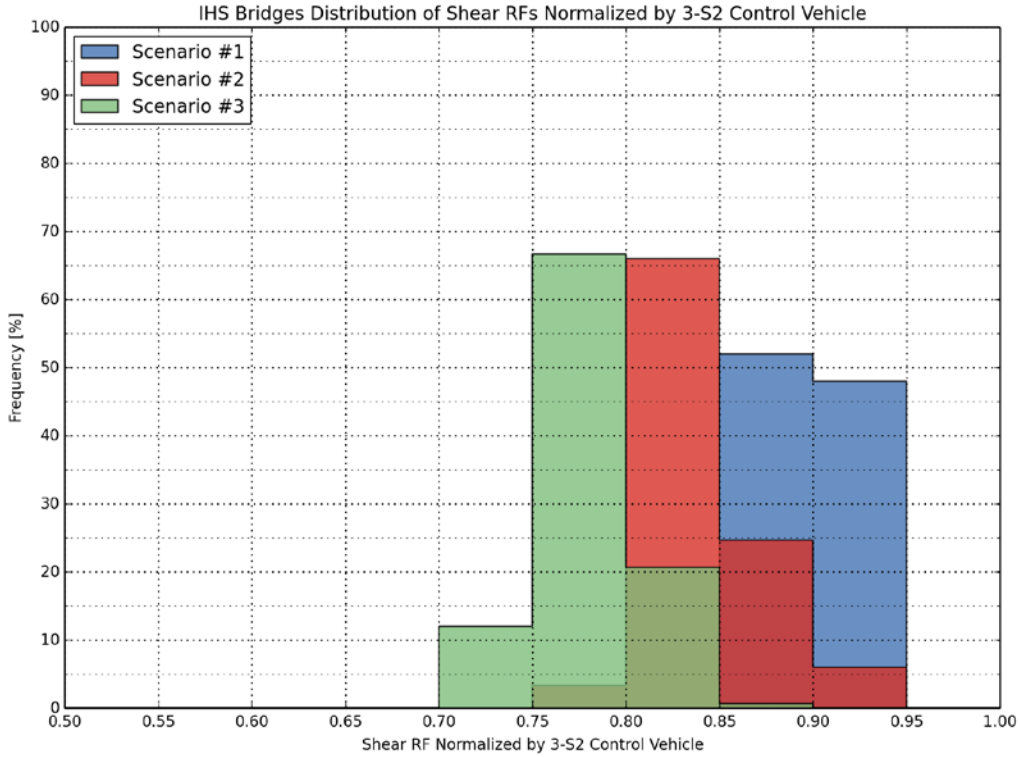
**DISTRIBUTION OF NORMALIZED RATING RESULTS (IHS BRIDGES)**



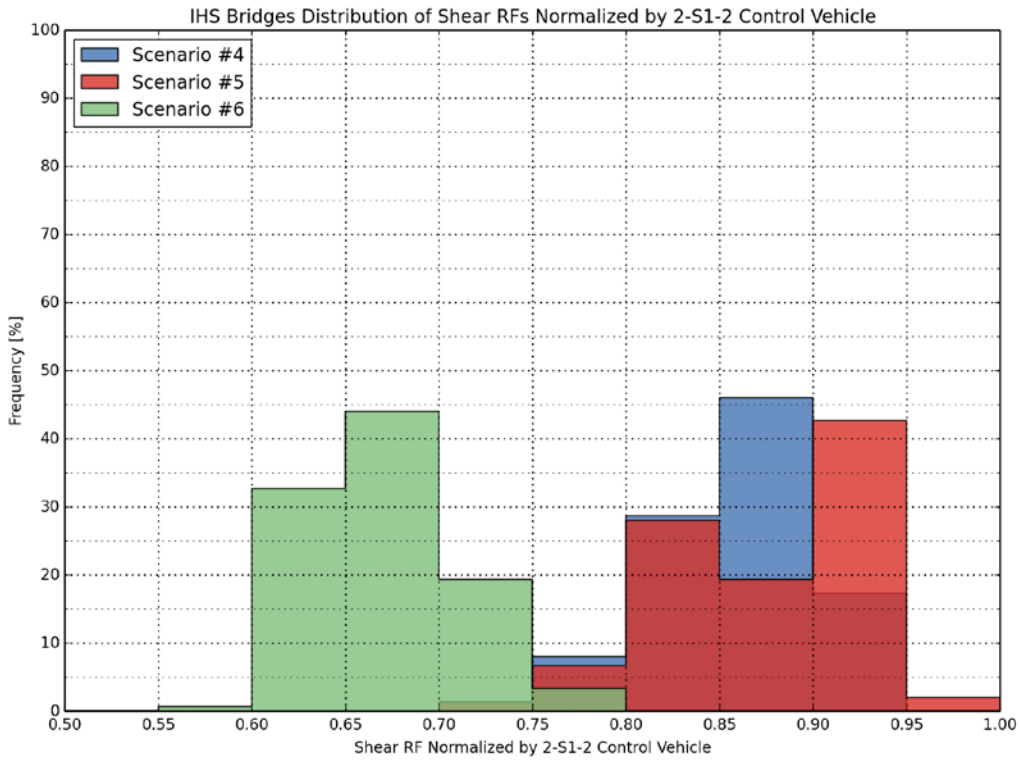
**Figure STR-31: Distribution of normalized flexural rating factors for IHS Bridges (3-S2, Scenario #1, #2 and #3)**



**Figure STR-32: Distribution of normalized flexural rating factors for IHS bridges (2-S1-2, Scenario #4, #5 and #6).**

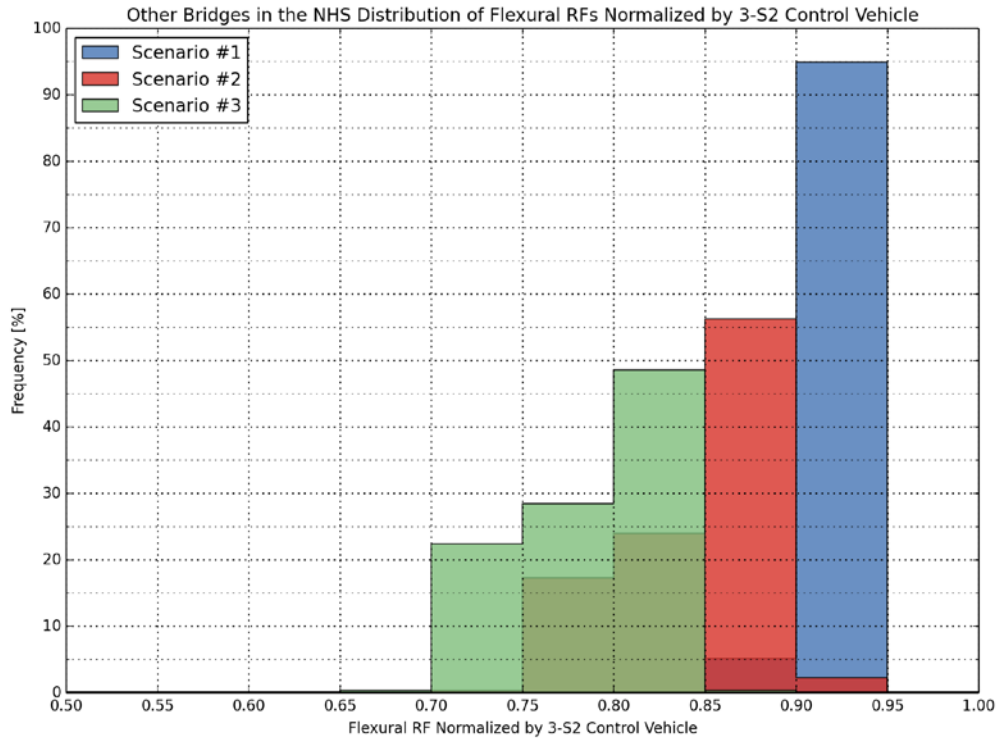


**Figure STR-33: Distribution of normalized shear rating factors for IHS Bridges (3-S2, Scenario #1, #2 and #3)**

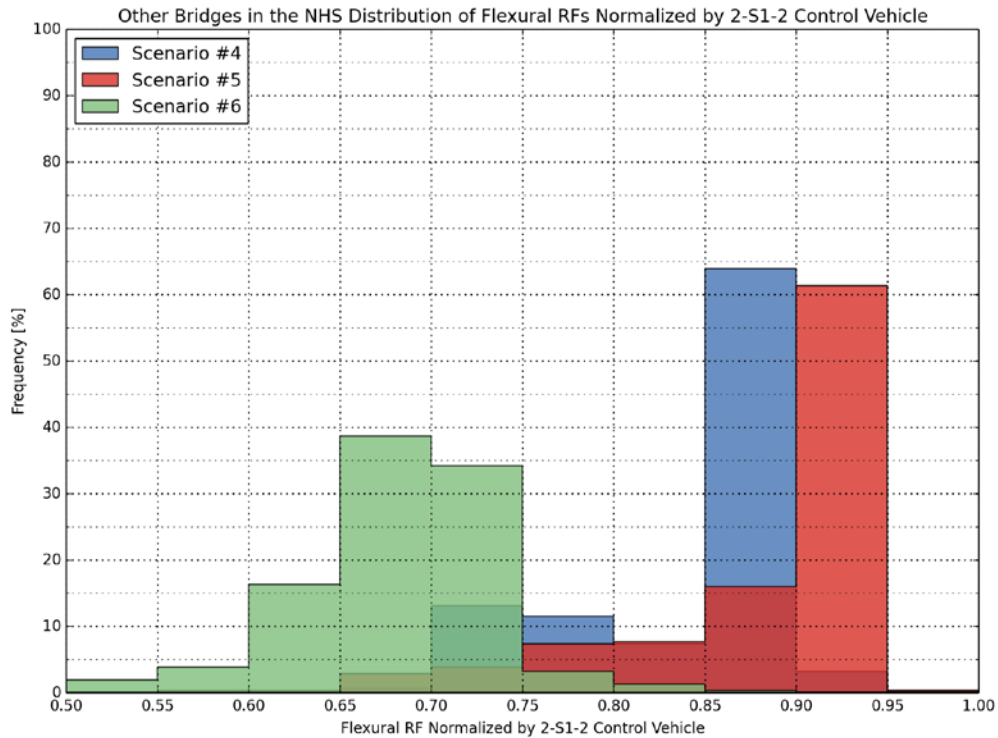


**Figure STR-34: Distribution of normalized shear rating factors for IHS bridges (2-S1-2, Scenario #4, #5 and #6)**

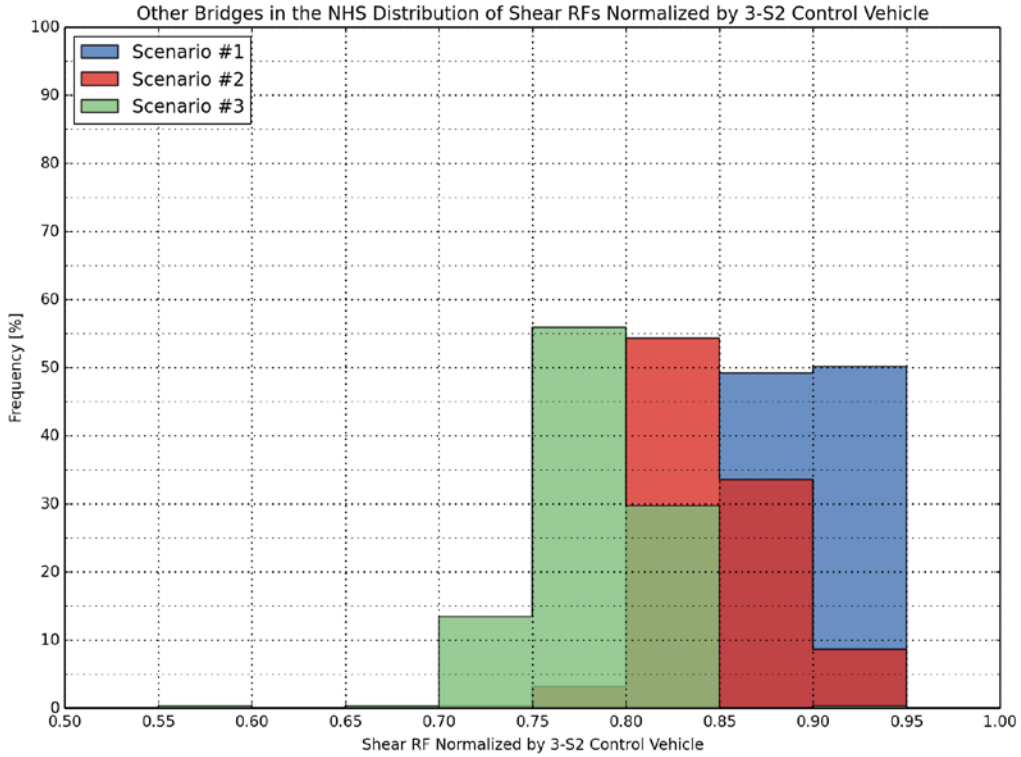
**DISTRIBUTION OF NORMALIZED RATING RESULTS (OTHER BRIDGES ON THE NHS)**



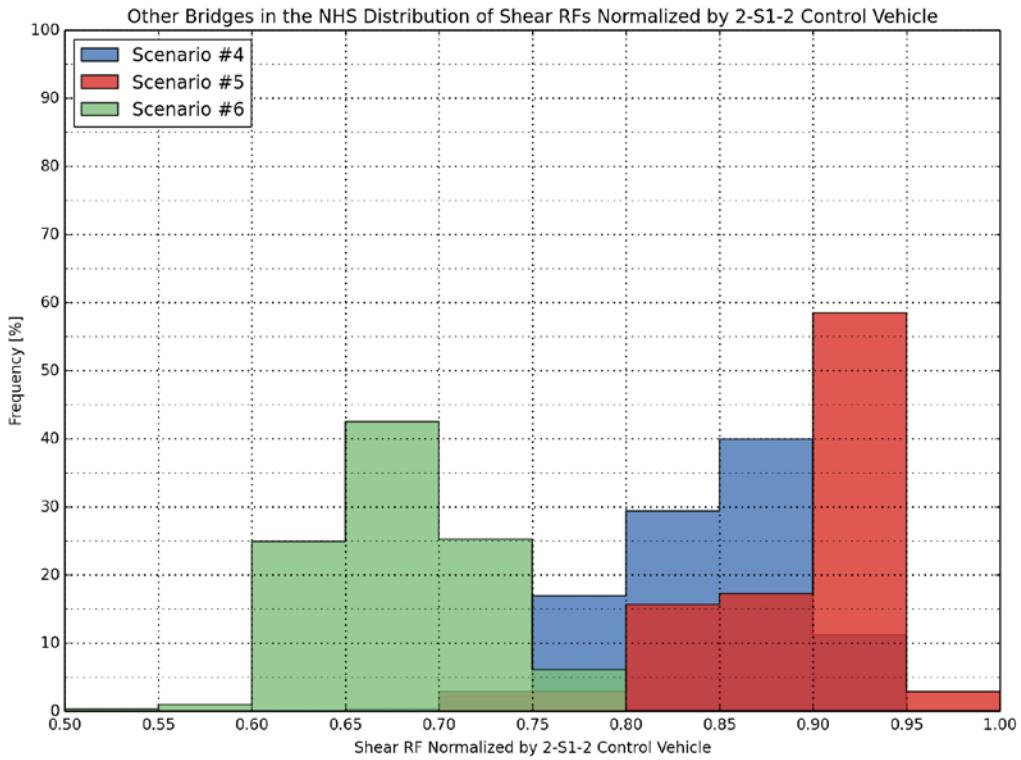
**Figure STR-35: Distribution of normalized flexural rating factors for other bridges on the NHS (3-S2, Scenario #1, #2 and #3)**



**Figure STR-36: Distribution of normalized flexural rating factors for other bridges on the NHS (2-S1-2, Scenario #4, #5 and #6)**



**Figure STR-37: Distribution of normalized shear rating factors for other bridges on the NHS (3-S2, Scenario #1, #2 and #3)**



**Figure STR-38: Distribution of normalized shear rating factors for other bridges on the NHS (2-S1-2, Scenario #4, #5 and #6)**



**LOAD RATING RESULTS FOR BRIDGE TYPES**

**Table STR-3: Flexural Rating Result Statistics for Reinforced Concrete Slabs**

		3-S2	Scenario #1	Scenario #2	Scenario #3	2-S1-2	Scenario #4	Scenario #5	Scenario #6
<b>ALL BRIDGES</b>	<b>AVERAGE</b>	1.999	1.798	1.611	1.489	2.903	2.231	2.618	2.141
	<b>MAX</b>	3.044	2.747	2.620	2.423	4.839	3.415	4.284	3.591
	<b>MIN</b>	0.804	0.730	0.631	0.583	1.186	0.888	1.092	0.852
	<b>TOTAL #</b>	58	58	58	58	58	58	58	58
	<b># RF &lt; 1.0</b>	4	5	8	10	0	3	0	4
<b>IHS BRIDGES</b>	<b>AVERAGE</b>	1.974	1.770	1.615	1.493	2.824	2.277	2.538	2.098
	<b>MAX</b>	2.634	2.372	2.138	1.975	4.055	3.219	3.591	3.292
	<b>MIN</b>	0.821	0.739	0.631	0.583	1.187	0.888	1.092	0.852
	<b>TOTAL #</b>	18	18	18	18	18	18	18	18
	<b># RF &lt; 1.0</b>	2	2	2	2	0	2	0	2
<b>OTHER BRIDGES ON THE NHS</b>	<b>AVERAGE</b>	2.011	1.811	1.610	1.487	2.939	2.211	2.654	2.161
	<b>MAX</b>	3.044	2.747	2.620	2.423	4.839	3.415	4.284	3.591
	<b>MIN</b>	0.804	0.730	0.659	0.608	1.186	0.953	1.093	0.860
	<b>TOTAL #</b>	40	40	40	40	40	40	40	40
	<b># RF &lt; 1.0</b>	2	3	6	8	0	1	0	2

**Table STR-4: Shear Rating Result Statistics for Reinforced Concrete Slabs**

		3-S2	Scenario #1	Scenario #2	Scenario #3	2-S1-2	Scenario #4	Scenario #5	Scenario #6
<b>ALL BRIDGES</b>	<b>AVERAGE</b>	3.969	3.565	3.339	3.060	5.517	4.302	5.094	4.029
	<b>MAX</b>	18.57	16.74	15.42	14.25	25.68	19.75	23.68	20.10
	<b>MIN</b>	1.619	1.425	1.335	1.190	2.254	1.855	2.089	1.606
	<b>TOTAL #</b>	58	58	58	58	58	58	58	58
	<b># RF &lt; 1.0</b>	0	0	0	0	0	0	0	0
<b>IHS BRIDGES</b>	<b>AVERAGE</b>	3.555	3.204	3.018	2.761	4.834	3.856	4.475	3.413
	<b>MAX</b>	6.52	5.85	5.67	5.18	8.98	7.18	8.45	6.29
	<b>MIN</b>	1.619	1.425	1.335	1.190	2.407	1.911	2.229	1.606
	<b>TOTAL #</b>	18	18	18	18	18	18	18	18
	<b># RF &lt; 1.0</b>	0	0	0	0	0	0	0	0
<b>OTHER BRIDGES ON THE NHS</b>	<b>AVERAGE</b>	4.155	3.728	3.484	3.194	5.824	4.503	5.372	4.307
	<b>MAX</b>	18.57	16.74	15.42	14.25	25.68	19.75	23.68	20.10
	<b>MIN</b>	1.769	1.609	1.485	1.372	2.254	1.855	2.089	1.667
	<b>TOTAL #</b>	40	40	40	40	40	40	40	40
	<b># RF &lt; 1.0</b>	0	0	0	0	0	0	0	0

**Table STR-5: Flexural Rating Result Statistics for Prestressed Concrete Beam/Girders, Simple Spans**

		3-S2	Scenario #1	Scenario #2	Scenario #3	2-S1-2	Scenario #4	Scenario #5	Scenario #6
<b>ALL BRIDGES</b>	<b>AVERAGE</b>	3.280	2.989	2.861	2.651	3.561	3.143	3.177	2.416
	<b>MAX</b>	4.835	4.407	4.191	3.892	5.172	4.543	4.749	3.553
	<b>MIN</b>	0.793	0.730	0.716	0.661	0.817	0.751	0.741	0.561
	<b>TOTAL #</b>	69	69	69	69	69	69	69	69
	<b># RF &lt; 1.0</b>	1	1	1	2	1	1	1	2
<b>IHS BRIDGES</b>	<b>AVERAGE</b>	3.257	2.968	2.836	2.628	3.534	3.136	3.136	2.390
	<b>MAX</b>	4.739	4.303	4.191	3.892	4.803	4.178	4.294	3.211
	<b>MIN</b>	0.793	0.730	0.716	0.661	0.817	0.751	0.741	0.561
	<b>TOTAL #</b>	30	30	30	30	30	30	30	30
	<b># RF &lt; 1.0</b>	1	1	1	2	1	1	1	2
<b>OTHER BRIDGES ON THE NHS</b>	<b>AVERAGE</b>	3.298	3.005	2.881	2.668	3.581	3.149	3.209	2.437
	<b>MAX</b>	4.835	4.407	4.175	3.857	5.172	4.543	4.749	3.553
	<b>MIN</b>	1.984	1.802	1.780	1.668	2.473	2.199	1.758	1.408
	<b>TOTAL #</b>	39	39	39	39	39	39	39	39
	<b># RF &lt; 1.0</b>	0	0	0	0	0	0	0	0

**Table STR-6: Shear Rating Result Statistics for Prestressed Concrete Beam/Girders, Simple Spans**

		3-S2	Scenario #1	Scenario #2	Scenario #3	2-S1-2	Scenario #4	Scenario #5	Scenario #6
<b>ALL BRIDGES</b>	<b>AVERAGE</b>	3.434	3.098	2.868	2.659	3.905	3.363	3.458	2.623
	<b>MAX</b>	7.44	6.72	5.97	5.53	8.00	6.74	7.29	5.48
	<b>MIN</b>	1.721	1.549	1.459	1.342	1.934	1.625	1.526	1.231
	<b>TOTAL #</b>	69	69	69	69	69	69	69	69
	<b># RF &lt; 1.0</b>	0	0	0	0	0	0	0	0
<b>IHS BRIDGES</b>	<b>AVERAGE</b>	3.179	2.868	2.665	2.469	3.597	3.101	3.171	2.412
	<b>MAX</b>	6.96	6.20	5.67	5.26	8.00	6.74	6.76	5.09
	<b>MIN</b>	1.721	1.549	1.459	1.342	1.934	1.625	1.526	1.231
	<b>TOTAL #</b>	30	30	30	30	30	30	30	30
	<b># RF &lt; 1.0</b>	0	0	0	0	0	0	0	0
<b>OTHER BRIDGES ON THE NHS</b>	<b>AVERAGE</b>	3.630	3.275	3.023	2.805	4.142	3.565	3.678	2.786
	<b>MAX</b>	7.44	6.72	5.97	5.53	7.82	6.71	7.29	5.48
	<b>MIN</b>	1.877	1.714	1.538	1.424	2.005	1.714	1.862	1.414
	<b>TOTAL #</b>	39	39	39	39	39	39	39	39
	<b># RF &lt; 1.0</b>	0	0	0	0	0	0	0	0

**Table STR-7: Flexural Rating Result Statistics for Prestressed Concrete Beam/Girders, Continuous Spans**

		3-S2	Scenario #1	Scenario #2	Scenario #3	2-S1-2	Scenario #4	Scenario #5	Scenario #6
<b>ALL BRIDGES</b>	<b>AVERAGE</b>	2.907	2.641	2.543	2.371	3.456	3.040	2.699	2.115
	<b>MAX</b>	4.781	4.344	4.273	4.017	6.185	5.610	4.323	3.213
	<b>MIN</b>	0.715	0.649	0.642	0.600	0.953	0.822	0.684	0.554
	<b>TOTAL #</b>	48	48	48	48	48	48	48	48
	<b># RF &lt; 1.0</b>	1	1	2	2	1	2	2	2
<b>IHS BRIDGES</b>	<b>AVERAGE</b>	2.978	2.706	2.616	2.444	3.733	3.313	2.754	2.168
	<b>MAX</b>	4.781	4.344	4.273	4.017	6.185	5.610	3.997	3.213
	<b>MIN</b>	0.715	0.649	0.642	0.600	0.953	0.822	0.684	0.554
	<b>TOTAL #</b>	16	16	16	16	16	16	16	16
	<b># RF &lt; 1.0</b>	1	1	1	1	1	1	1	1
<b>OTHER BRIDGES ON THE NHS</b>	<b>AVERAGE</b>	2.872	2.608	2.506	2.335	3.317	2.903	2.672	2.088
	<b>MAX</b>	4.636	4.195	4.007	3.749	4.918	4.378	4.323	3.192
	<b>MIN</b>	1.124	1.019	0.934	0.868	1.068	0.983	0.971	0.750
	<b>TOTAL #</b>	32	32	32	32	32	32	32	32
	<b># RF &lt; 1.0</b>	0	0	1	1	0	1	1	1

**Table STR-8: Shear Rating Result Statistics for Prestressed Concrete Beam/Girders, Continuous Spans**

		3-S2	Scenario #1	Scenario #2	Scenario #3	2-S1-2	Scenario #4	Scenario #5	Scenario #6
<b>ALL BRIDGES</b>	<b>AVERAGE</b>	3.382	3.059	2.872	2.663	3.850	3.321	3.370	2.598
	<b>MAX</b>	6.19	5.54	5.31	4.91	6.90	6.06	6.16	4.56
	<b>MIN</b>	1.435	1.295	1.234	1.155	1.628	1.451	1.189	0.984
	<b>TOTAL #</b>	48	48	48	48	48	48	48	48
	<b># RF &lt; 1.0</b>	0	0	0	0	0	0	0	1
<b>IHS BRIDGES</b>	<b>AVERAGE</b>	3.261	2.948	2.735	2.535	3.609	3.116	3.150	2.435
	<b>MAX</b>	6.19	5.54	5.31	4.91	6.90	6.06	5.86	4.55
	<b>MIN</b>	1.435	1.295	1.234	1.155	1.628	1.451	1.189	0.984
	<b>TOTAL #</b>	16	16	16	16	16	16	16	16
	<b># RF &lt; 1.0</b>	0	0	0	0	0	0	0	1
<b>OTHER BRIDGES ON THE NHS</b>	<b>AVERAGE</b>	3.443	3.115	2.940	2.726	3.970	3.424	3.481	2.680
	<b>MAX</b>	5.35	4.82	4.51	4.22	6.60	5.48	6.16	4.56
	<b>MIN</b>	1.689	1.549	1.423	1.317	1.841	1.568	1.673	1.304
	<b>TOTAL #</b>	32	32	32	32	32	32	32	32
	<b># RF &lt; 1.0</b>	0	0	0	0	0	0	0	0

**Table STR-9: Flexural Rating Result Statistics for Steel Beam/Girder, Simple Span  
(L < 100 ft.)**

		3-S2	Scenario #1	Scenario #2	Scenario #3	2-S1-2	Scenario #4	Scenario #5	Scenario #6
<b>ALL BRIDGES</b>	<b>AVERAGE</b>	2.888	2.629	2.446	2.261	3.456	2.954	3.178	2.347
	<b>MAX</b>	5.491	5.028	4.888	4.516	6.753	5.569	6.219	4.383
	<b>MIN</b>	0.820	0.738	0.631	0.583	1.187	0.888	1.092	0.852
	<b>TOTAL #</b>	52	52	52	52	52	52	52	52
	<b># RF &lt; 1.0</b>	2	2	4	4	0	2	0	2
<b>IHS BRIDGES</b>	<b>AVERAGE</b>	3.360	3.057	2.847	2.633	3.854	3.337	3.538	2.633
	<b>MAX</b>	5.491	5.028	4.888	4.516	5.786	5.202	5.340	4.065
	<b>MIN</b>	2.332	2.109	1.852	1.711	2.407	2.146	2.124	1.662
	<b>TOTAL #</b>	14	14	14	14	14	14	14	14
	<b># RF &lt; 1.0</b>	0	0	0	0	0	0	0	0
<b>OTHER BRIDGES ON THE NHS</b>	<b>AVERAGE</b>	2.715	2.472	2.298	2.124	3.309	2.812	3.045	2.242
	<b>MAX</b>	4.871	4.422	4.030	3.723	6.753	5.569	6.219	4.383
	<b>MIN</b>	0.820	0.738	0.631	0.583	1.187	0.888	1.092	0.852
	<b>TOTAL #</b>	38	38	38	38	38	38	38	38
	<b># RF &lt; 1.0</b>	2	2	4	4	0	2	0	2

**Table STR-10: Shear Rating Result Statistics for Steel Beam/Girder, Simple Span  
(L < 100 ft.)**

		3-S2	Scenario #1	Scenario #2	Scenario #3	2-S1-2	Scenario #4	Scenario #5	Scenario #6
<b>ALL BRIDGES</b>	<b>AVERAGE</b>	5.296	4.796	4.499	4.165	6.169	5.222	5.642	4.239
	<b>MAX</b>	15.66	14.10	12.54	11.61	16.45	14.10	15.26	11.52
	<b>MIN</b>	1.619	1.425	1.335	1.190	2.063	1.785	1.789	1.356
	<b>TOTAL #</b>	52	52	52	52	52	52	52	52
	<b># RF &lt; 1.0</b>	0	0	0	0	0	0	0	0
<b>IHS BRIDGES</b>	<b>AVERAGE</b>	4.741	4.300	4.060	3.763	5.591	4.757	5.075	3.810
	<b>MAX</b>	6.98	6.40	5.99	5.56	7.89	6.68	7.25	5.45
	<b>MIN</b>	2.641	2.370	2.206	2.057	3.011	2.721	2.476	1.931
	<b>TOTAL #</b>	14	14	14	14	14	14	14	14
	<b># RF &lt; 1.0</b>	0	0	0	0	0	0	0	0
<b>OTHER BRIDGES ON THE NHS</b>	<b>AVERAGE</b>	5.500	4.980	4.661	4.313	6.382	5.393	5.851	4.398
	<b>MAX</b>	15.66	14.10	12.54	11.61	16.45	14.10	15.26	11.52
	<b>MIN</b>	1.619	1.425	1.335	1.190	2.063	1.785	1.789	1.356
	<b>TOTAL #</b>	38	38	38	38	38	38	38	38
	<b># RF &lt; 1.0</b>	0	0	0	0	0	0	0	0

**Table STR-11: Flexural Rating Result Statistics for Steel Beam/Girder, Simple Span  
(L > 100 ft.)**

		3-S2	Scenario #1	Scenario #2	Scenario #3	2-S1-2	Scenario #4	Scenario #5	Scenario #6
<b>ALL BRIDGES</b>	<b>AVERAGE</b>	3.135	2.847	2.737	2.546	3.309	2.928	2.791	2.203
	<b>MAX</b>	4.982	4.523	4.403	4.092	4.922	4.385	4.341	3.365
	<b>MIN</b>	1.291	1.172	1.121	1.041	1.387	1.241	1.215	0.945
	<b>TOTAL #</b>	36	36	36	36	36	36	36	36
	<b># RF &lt; 1.0</b>	0	0	0	0	0	0	0	3
<b>IHS BRIDGES</b>	<b>AVERAGE</b>	3.253	2.955	2.854	2.655	3.382	2.998	2.853	2.255
	<b>MAX</b>	4.982	4.523	4.403	4.092	4.922	4.385	4.284	3.365
	<b>MIN</b>	1.335	1.211	1.196	1.120	1.819	1.563	1.237	0.996
	<b>TOTAL #</b>	19	19	19	19	19	19	19	19
	<b># RF &lt; 1.0</b>	0	0	0	0	0	0	0	1
<b>OTHER BRIDGES ON THE NHS</b>	<b>AVERAGE</b>	3.004	2.726	2.607	2.425	3.229	2.851	2.722	2.145
	<b>MAX</b>	4.923	4.470	4.350	4.045	4.910	4.373	4.341	3.342
	<b>MIN</b>	1.291	1.172	1.121	1.041	1.387	1.241	1.215	0.945
	<b>TOTAL #</b>	17	17	17	17	17	17	17	17
	<b># RF &lt; 1.0</b>	0	0	0	0	0	0	0	2

**Table STR-12: Shear Rating Result Statistics for Steel Beam/Girder, Simple Span  
(L > 100 ft.)**

		3-S2	Scenario #1	Scenario #2	Scenario #3	2-S1-2	Scenario #4	Scenario #5	Scenario #6
<b>ALL BRIDGES</b>	<b>AVERAGE</b>	4.014	3.613	3.393	3.159	4.634	4.085	3.794	2.968
	<b>MAX</b>	13.58	12.27	11.73	10.99	15.40	13.70	13.12	9.35
	<b>MIN</b>	0.707	0.635	0.591	0.552	0.806	0.728	0.660	0.516
	<b>TOTAL #</b>	36	36	36	36	36	36	36	36
	<b># RF &lt; 1.0</b>	2	2	2	2	1	1	2	2
<b>IHS BRIDGES</b>	<b>AVERAGE</b>	4.342	3.901	3.654	3.398	4.996	4.393	4.117	3.199
	<b>MAX</b>	13.58	12.27	11.73	10.99	15.40	13.70	13.12	9.35
	<b>MIN</b>	0.997	0.896	0.837	0.781	1.136	1.024	0.922	0.723
	<b>TOTAL #</b>	19	19	19	19	19	19	19	19
	<b># RF &lt; 1.0</b>	1	1	1	1	0	0	1	1
<b>OTHER BRIDGES ON THE NHS</b>	<b>AVERAGE</b>	3.648	3.290	3.102	2.892	4.229	3.742	3.433	2.710
	<b>MAX</b>	6.86	6.17	5.81	5.44	7.81	7.04	6.61	4.96
	<b>MIN</b>	0.707	0.635	0.591	0.552	0.806	0.728	0.660	0.516
	<b>TOTAL #</b>	17	17	17	17	17	17	17	17
	<b># RF &lt; 1.0</b>	1	1	1	1	1	1	1	1

**Table STR-13: Flexural Rating Result Statistics for Steel Beam/Girder, Continuous Spans  
(L < 100 ft.)**

		3-S2	Scenario #1	Scenario #2	Scenario #3	2-S1-2	Scenario #4	Scenario #5	Scenario #6
<b>ALL BRIDGES</b>	<b>AVERAGE</b>	2.751	2.486	2.383	2.217	3.316	2.867	2.693	2.123
	<b>MAX</b>	5.528	5.002	4.850	4.550	6.631	5.833	4.937	4.071
	<b>MIN</b>	1.163	1.056	1.022	0.951	1.266	1.112	1.000	0.801
	<b>TOTAL #</b>	49	49	49	49	49	49	49	49
	<b># RF &lt; 1.0</b>	0	0	0	1	0	0	0	1
<b>IHS BRIDGES</b>	<b>AVERAGE</b>	2.486	2.238	2.133	1.983	3.025	2.544	2.460	1.910
	<b>MAX</b>	3.586	3.259	3.178	2.958	4.077	3.536	3.702	2.607
	<b>MIN</b>	1.570	1.423	1.421	1.330	1.832	1.640	1.422	1.163
	<b>TOTAL #</b>	21	21	21	21	21	21	21	21
	<b># RF &lt; 1.0</b>	0	0	0	0	0	0	0	0
<b>OTHER BRIDGES ON THE NHS</b>	<b>AVERAGE</b>	2.950	2.672	2.570	2.393	3.535	3.110	2.868	2.282
	<b>MAX</b>	5.528	5.002	4.850	4.550	6.631	5.833	4.937	4.071
	<b>MIN</b>	1.163	1.056	1.022	0.951	1.266	1.112	1.000	0.801
	<b>TOTAL #</b>	28	28	28	28	28	28	28	28
	<b># RF &lt; 1.0</b>	0	0	0	1	0	0	0	1

**Table STR-14: Shear Rating Result Statistics for Steel Beam/Girder, Continuous Spans  
(L < 100 ft.)**

		3-S2	Scenario #1	Scenario #2	Scenario #3	2-S1-2	Scenario #4	Scenario #5	Scenario #6
<b>ALL BRIDGES</b>	<b>AVERAGE</b>	4.599	4.161	3.884	3.599	5.140	4.414	4.607	3.543
	<b>MAX</b>	7.97	7.12	6.50	6.05	8.82	7.68	7.59	5.79
	<b>MIN</b>	1.417	1.265	1.142	1.061	1.703	1.398	1.448	1.094
	<b>TOTAL #</b>	49	49	49	49	49	49	49	49
	<b># RF &lt; 1.0</b>	0	0	0	0	0	0	0	0
<b>IHS BRIDGES</b>	<b>AVERAGE</b>	4.614	4.167	3.888	3.605	5.266	4.517	4.671	3.580
	<b>MAX</b>	7.97	7.12	6.50	6.05	8.82	7.68	7.59	5.79
	<b>MIN</b>	1.588	1.426	1.328	1.239	1.811	1.636	1.486	1.160
	<b>TOTAL #</b>	21	21	21	21	21	21	21	21
	<b># RF &lt; 1.0</b>	0	0	0	0	0	0	0	0
<b>OTHER BRIDGES ON THE NHS</b>	<b>AVERAGE</b>	4.587	4.157	3.880	3.595	5.045	4.337	4.558	3.515
	<b>MAX</b>	7.59	6.76	6.24	5.77	8.30	7.14	7.42	5.63
	<b>MIN</b>	1.417	1.265	1.142	1.061	1.703	1.398	1.448	1.094
	<b>TOTAL #</b>	28	28	28	28	28	28	28	28
	<b># RF &lt; 1.0</b>	0	0	0	0	0	0	0	0

**Table STR-15: Flexural Rating Result Statistics for Steel Beam/Girder, Continuous Spans  
(L > 100 ft.)**

		3-S2	Scenario #1	Scenario #2	Scenario #3	2-S1-2	Scenario #4	Scenario #5	Scenario #6
<b>ALL BRIDGES</b>	<b>AVERAGE</b>	2.890	2.625	2.516	2.342	3.120	2.754	2.551	2.034
	<b>MAX</b>	7.318	6.651	6.477	6.050	7.835	6.936	5.903	4.794
	<b>MIN</b>	1.245	1.127	1.075	1.006	1.358	1.215	1.015	0.827
	<b>TOTAL #</b>	44	44	44	44	44	44	44	44
	<b># RF &lt; 1.0</b>	0	0	0	0	0	0	0	1
<b>IHS BRIDGES</b>	<b>AVERAGE</b>	2.739	2.483	2.349	2.191	2.945	2.598	2.403	1.938
	<b>MAX</b>	4.366	3.957	3.713	3.468	4.560	4.134	3.638	2.922
	<b>MIN</b>	1.245	1.127	1.075	1.006	1.358	1.215	1.015	0.827
	<b>TOTAL #</b>	11	11	11	11	11	11	11	11
	<b># RF &lt; 1.0</b>	0	0	0	0	0	0	0	1
<b>OTHER BRIDGES ON THE NHS</b>	<b>AVERAGE</b>	2.941	2.672	2.571	2.393	3.179	2.806	2.600	2.066
	<b>MAX</b>	7.318	6.651	6.477	6.050	7.835	6.936	5.903	4.794
	<b>MIN</b>	1.260	1.151	1.094	1.010	1.524	1.319	1.243	1.007
	<b>TOTAL #</b>	33	33	33	33	33	33	33	33
	<b># RF &lt; 1.0</b>	0	0	0	0	0	0	0	0

**Table STR-16: Shear Rating Result Statistics for Steel Beam/Girder, Continuous Spans  
(L > 100 ft.)**

		3-S2	Scenario #1	Scenario #2	Scenario #3	2-S1-2	Scenario #4	Scenario #5	Scenario #6
<b>ALL BRIDGES</b>	<b>AVERAGE</b>	3.351	3.020	2.835	2.640	3.847	3.392	3.178	2.495
	<b>MAX</b>	8.37	7.56	7.21	6.76	9.47	8.44	7.82	5.72
	<b>MIN</b>	1.609	1.444	1.343	1.253	1.822	1.579	1.509	1.176
	<b>TOTAL #</b>	44	44	44	44	44	44	44	44
	<b># RF &lt; 1.0</b>	0	0	0	0	0	0	0	0
<b>IHS BRIDGES</b>	<b>AVERAGE</b>	2.916	2.617	2.441	2.274	3.345	2.957	2.764	2.152
	<b>MAX</b>	3.90	3.50	3.27	3.05	4.36	3.95	3.56	2.79
	<b>MIN</b>	2.023	1.819	1.705	1.593	2.279	2.054	1.829	1.438
	<b>TOTAL #</b>	11	11	11	11	11	11	11	11
	<b># RF &lt; 1.0</b>	0	0	0	0	0	0	0	0
<b>OTHER BRIDGES ON THE NHS</b>	<b>AVERAGE</b>	3.496	3.154	2.966	2.762	4.014	3.537	3.317	2.610
	<b>MAX</b>	8.37	7.56	7.21	6.76	9.47	8.44	7.82	5.72
	<b>MIN</b>	1.609	1.444	1.343	1.253	1.822	1.579	1.509	1.176
	<b>TOTAL #</b>	33	33	33	33	33	33	33	33
	<b># RF &lt; 1.0</b>	0	0	0	0	0	0	0	0

**Table STR-17: LFR Rating Factors for Girder Floorbeam Systems**

		3-S2	Scenario #1	Scenario #2	Scenario #3	2-S1-2	Scenario #4	Scenario #5	Scenario #6
ALL BRIDGES	AVERAGE	2.376	2.138	2.024	1.875	3.039	2.560	2.633	2.117
	MAX	4.561	4.093	3.809	3.552	5.200	4.699	4.275	3.335
	MIN	1.446	1.303	1.284	1.186	2.163	1.685	1.745	1.406
	TOTAL #	11	11	11	11	11	11	11	11
	# RF < 1.0	0	0	0	0	0	0	0	0
IHS BRIDGES	AVERAGE	2.057	1.855	1.957	1.808	2.823	2.385	2.450	2.066
	MAX	2.667	2.406	2.630	2.430	3.410	3.084	3.155	2.725
	MIN	1.446	1.303	1.284	1.186	2.236	1.685	1.745	1.406
	TOTAL #	2	2	2	2	2	2	2	2
	# RF < 1.0	0	0	0	0	0	0	0	0
OTHER BRIDGES ON THE NHS	AVERAGE	2.447	2.201	2.039	1.890	3.087	2.599	2.673	2.129
	MAX	4.561	4.093	3.809	3.552	5.200	4.699	4.275	3.335
	MIN	1.538	1.384	1.404	1.298	2.163	1.914	1.790	1.441
	TOTAL #	9	9	9	9	9	9	9	9
	# RF < 1.0	0	0	0	0	0	0	0	0

NOTE: Rating factors determined based on the LFR methodology. Separate flexural/shear rating factors unavailable

**Table STR-18: Flexural Rating Result Statistics for Reinforced Concrete Tee Beams**

		3-S2	Scenario #1	Scenario #2	Scenario #3	2-S1-2	Scenario #4	Scenario #5	Scenario #6
ALL BRIDGES	AVERAGE	1.879	1.704	1.551	1.434	2.528	2.055	2.313	1.737
	MAX	3.708	3.387	3.228	2.982	4.609	4.046	4.243	3.022
	MIN	0.748	0.675	0.589	0.545	1.095	0.824	1.006	0.755
	TOTAL #	53	53	53	53	53	53	53	53
	# RF < 1.0	4	7	10	13	0	4	0	7
IHS BRIDGES	AVERAGE	2.418	2.195	2.049	1.898	3.055	2.586	2.753	2.079
	MAX	3.708	3.387	3.228	2.982	4.609	4.046	4.243	3.007
	MIN	1.508	1.364	1.230	1.136	1.886	1.726	1.625	1.308
	TOTAL #	11	11	11	11	11	11	11	11
	# RF < 1.0	0	0	0	0	0	0	0	0
OTHER BRIDGES ON THE NHS	AVERAGE	1.738	1.575	1.420	1.312	2.390	1.916	2.198	1.647
	MAX	3.097	2.811	2.526	2.334	4.282	3.616	3.740	3.022
	MIN	0.748	0.675	0.589	0.545	1.095	0.824	1.006	0.755
	TOTAL #	42	42	42	42	42	42	42	42
	# RF < 1.0	4	7	10	13	0	4	0	7



**Table STR-19: Shear Rating Result Statistics for Reinforced Concrete Tee Beams**

		3-S2	Scenario #1	Scenario #2	Scenario #3	2-S1-2	Scenario #4	Scenario #5	Scenario #6
<b>ALL BRIDGES</b>	<b>AVERAGE</b>	2.843	2.552	2.435	2.228	3.902	3.100	3.583	2.641
	<b>MAX</b>	19.86	18.06	17.38	16.06	28.07	22.55	26.26	19.55
	<b>MIN</b>	0.715	0.626	0.610	0.541	1.033	0.790	0.954	0.610
	<b>TOTAL #</b>	53	53	53	53	53	53	53	53
	<b># RF &lt; 1.0</b>	2	5	6	8	0	1	1	5
<b>IHS BRIDGES</b>	<b>AVERAGE</b>	2.770	2.496	2.359	2.169	3.507	2.893	3.144	2.360
	<b>MAX</b>	4.57	4.17	4.08	3.77	5.88	4.91	5.52	4.04
	<b>MIN</b>	1.111	1.015	1.008	0.932	1.198	1.014	1.065	0.844
	<b>TOTAL #</b>	11	11	11	11	11	11	11	11
	<b># RF &lt; 1.0</b>	0	0	0	1	0	0	0	1
<b>OTHER BRIDGES ON THE NHS</b>	<b>AVERAGE</b>	2.862	2.567	2.455	2.244	4.005	3.155	3.698	2.715
	<b>MAX</b>	19.86	18.06	17.38	16.06	28.07	22.55	26.26	19.55
	<b>MIN</b>	0.715	0.626	0.610	0.541	1.033	0.790	0.954	0.610
	<b>TOTAL #</b>	42	42	42	42	42	42	42	42
	<b># RF &lt; 1.0</b>	2	5	6	7	0	1	1	4

**Table STR-20: Flexural Rating Result Statistics for Box Beams**

		3-S2	Scenario #1	Scenario #2	Scenario #3	2-S1-2	Scenario #4	Scenario #5	Scenario #6
<b>ALL BRIDGES</b>	<b>AVERAGE</b>	3.362	3.066	2.902	2.686	3.805	3.280	3.462	2.596
	<b>MAX</b>	8.429	7.725	7.526	6.969	8.350	7.465	7.698	5.871
	<b>MIN</b>	1.254	1.144	1.078	0.996	1.459	1.308	1.285	1.015
	<b>TOTAL #</b>	54	54	54	54	54	54	54	54
	<b># RF &lt; 1.0</b>	0	0	0	1	0	0	0	0
<b>IHS BRIDGES</b>	<b>AVERAGE</b>	3.869	3.519	3.400	3.157	3.983	3.530	3.460	2.714
	<b>MAX</b>	8.337	7.598	7.461	6.943	8.350	7.430	7.023	5.641
	<b>MIN</b>	1.542	1.405	1.392	1.293	1.563	1.390	1.285	1.047
	<b>TOTAL #</b>	10	10	10	10	10	10	10	10
	<b># RF &lt; 1.0</b>	0	0	0	0	0	0	0	0
<b>OTHER BRIDGES ON THE NHS</b>	<b>AVERAGE</b>	3.247	2.963	2.789	2.579	3.765	3.223	3.463	2.569
	<b>MAX</b>	8.429	7.725	7.526	6.969	8.329	7.465	7.698	5.871
	<b>MIN</b>	1.254	1.144	1.078	0.996	1.459	1.308	1.349	1.015
	<b>TOTAL #</b>	44	44	44	44	44	44	44	44
	<b># RF &lt; 1.0</b>	0	0	0	1	0	0	0	0

**Table STR-21: Shear Rating Result Statistics for Box Beams**

		3-S2	Scenario #1	Scenario #2	Scenario #3	2-S1-2	Scenario #4	Scenario #5	Scenario #6
<b>ALL BRIDGES</b>	<b>AVERAGE</b>	3.592	3.236	3.053	2.815	4.364	3.678	3.966	2.973
	<b>MAX</b>	17.69	16.04	15.17	14.01	24.86	19.69	23.04	18.16
	<b>MIN</b>	1.450	1.340	1.301	1.211	1.669	1.479	1.544	1.163
	<b>TOTAL #</b>	54	54	54	54	54	54	54	54
	<b># RF &lt; 1.0</b>	0	0	0	0	0	0	0	0
<b>IHS BRIDGES</b>	<b>AVERAGE</b>	3.207	2.887	2.717	2.523	3.769	3.295	3.243	2.490
	<b>MAX</b>	4.79	4.36	4.21	3.89	6.43	5.27	5.91	4.54
	<b>MIN</b>	2.106	1.893	1.773	1.656	2.398	2.158	1.929	1.521
	<b>TOTAL #</b>	10	10	10	10	10	10	10	10
	<b># RF &lt; 1.0</b>	0	0	0	0	0	0	0	0
<b>OTHER BRIDGES ON THE NHS</b>	<b>AVERAGE</b>	3.680	3.316	3.129	2.881	4.499	3.765	4.130	3.082
	<b>MAX</b>	17.69	16.04	15.17	14.01	24.86	19.69	23.04	18.16
	<b>MIN</b>	1.450	1.340	1.301	1.211	1.669	1.479	1.544	1.163
	<b>TOTAL #</b>	44	44	44	44	44	44	44	44
	<b># RF &lt; 1.0</b>	0	0	0	0	0	0	0	0

**Table STR-22: LFR Rating Factors for Through Trusses**

		3-S2	Scenario #1	Scenario #2	Scenario #3	2-S1-2	Scenario #4	Scenario #5	Scenario #6
<b>ALL BRIDGES</b>	<b>AVERAGE</b>	2.982	2.696	2.552	2.381	3.339	2.981	2.570	2.100
	<b>MAX</b>	6.849	6.181	5.875	5.499	7.777	6.937	5.738	4.761
	<b>MIN</b>	1.745	1.571	1.485	1.371	1.932	1.710	1.511	1.236
	<b>TOTAL #</b>	16	16	16	16	16	16	16	16
	<b># RF &lt; 1.0</b>	0	0	0	0	0	0	0	0
<b>IHS BRIDGES</b>	<b>AVERAGE</b>	3.313	3.023	2.842	2.625	3.993	3.557	2.924	2.401
	<b>MAX</b>	3.313	3.023	2.842	2.625	3.993	3.557	2.924	2.401
	<b>MIN</b>	3.313	3.023	2.842	2.625	3.993	3.557	2.924	2.401
	<b>TOTAL #</b>	1	1	1	1	1	1	1	1
	<b># RF &lt; 1.0</b>	0	0	0	0	0	0	0	0
<b>OTHER BRIDGES ON THE NHS</b>	<b>AVERAGE</b>	2.960	2.674	2.532	2.364	3.296	2.942	2.547	2.080
	<b>MAX</b>	6.849	6.181	5.875	5.499	7.777	6.937	5.738	4.761
	<b>MIN</b>	1.745	1.571	1.485	1.371	1.932	1.710	1.511	1.236
	<b>TOTAL #</b>	15	15	15	15	15	15	15	15
	<b># RF &lt; 1.0</b>	0	0	0	0	0	0	0	0

NOTE: Rating factors determined based on the LFR methodology.

**NORMALIZED LOAD RATING RESULTS FOR BRIDGE TYPES**

**Table STR-23: Normalized Flexural Rating Result Statistics for Reinforced Concrete Slabs**

		NORMALIZED BY 3-S2			NORMALIZED BY 2-S1-2		
		Scenario #1	Scenario #2	Scenario #3	Scenario #4	Scenario #5	Scenario #6
<b>ALL BRIDGES</b>	<b>AVERAGE</b>	0.904	0.825	0.764	0.823	0.890	0.694
	<b>MAX</b>	0.918	0.895	0.838	0.915	0.928	0.759
	<b>MIN</b>	0.879	0.743	0.686	0.702	0.665	0.546
	<b>COV [%]</b>	0.8%	5.2%	5.5%	8.2%	6.2%	6.5%
<b>IHS BRIDGES</b>	<b>AVERAGE</b>	0.904	0.814	0.752	0.811	0.914	0.696
	<b>MAX</b>	0.913	0.885	0.820	0.893	0.927	0.752
	<b>MIN</b>	0.884	0.743	0.686	0.702	0.887	0.648
	<b>COV [%]</b>	0.7%	5.4%	5.5%	8.0%	1.2%	5.1%
<b>OTHER BRIDGES ON THE NHS</b>	<b>AVERAGE</b>	0.904	0.830	0.769	0.829	0.879	0.693
	<b>MAX</b>	0.918	0.895	0.838	0.915	0.928	0.759
	<b>MIN</b>	0.879	0.768	0.710	0.710	0.665	0.546
	<b>COV [%]</b>	0.8%	5.2%	5.6%	8.5%	7.0%	7.0%

**Table STR-24: Normalized Shear Rating Result Statistics for Reinforced Concrete Slabs**

		NORMALIZED BY 3-S2			NORMALIZED BY 2-S1-2		
		Scenario #1	Scenario #2	Scenario #3	Scenario #4	Scenario #5	Scenario #6
<b>ALL BRIDGES</b>	<b>AVERAGE</b>	0.901	0.846	0.780	0.821	0.903	0.696
	<b>MAX</b>	0.917	0.919	0.912	0.906	0.950	0.779
	<b>MIN</b>	0.880	0.790	0.728	0.726	0.809	0.612
	<b>COV [%]</b>	1.2%	3.7%	4.5%	6.1%	4.2%	6.2%
<b>IHS BRIDGES</b>	<b>AVERAGE</b>	0.897	0.847	0.774	0.804	0.916	0.682
	<b>MAX</b>	0.917	0.907	0.838	0.906	0.950	0.761
	<b>MIN</b>	0.880	0.819	0.747	0.760	0.828	0.612
	<b>COV [%]</b>	1.2%	2.6%	2.9%	5.7%	3.5%	6.9%
<b>OTHER BRIDGES ON THE NHS</b>	<b>AVERAGE</b>	0.902	0.846	0.782	0.829	0.898	0.703
	<b>MAX</b>	0.917	0.919	0.912	0.904	0.946	0.779
	<b>MIN</b>	0.884	0.790	0.728	0.726	0.809	0.633
	<b>COV [%]</b>	1.2%	4.2%	5.1%	6.3%	4.3%	5.9%

**Table STR-25: Normalized Flexural Rating Result Statistics for Prestressed Concrete Beam/Girders, Simple Spans**

		NORMALIZED BY 3-S2			NORMALIZED BY 2-S1-2		
		Scenario #1	Scenario #2	Scenario #3	Scenario #4	Scenario #5	Scenario #6
<b>ALL BRIDGES</b>	<b>AVERAGE</b>	0.903	0.833	0.772	0.824	0.880	0.690
	<b>MAX</b>	0.917	0.903	0.845	0.956	0.927	0.801
	<b>MIN</b>	0.725	0.652	0.605	0.530	0.512	0.387
	<b>COV [%]</b>	2.5%	5.5%	5.6%	9.7%	8.3%	9.3%
<b>IHS BRIDGES</b>	<b>AVERAGE</b>	0.899	0.825	0.765	0.819	0.863	0.685
	<b>MAX</b>	0.916	0.891	0.830	0.907	0.923	0.801
	<b>MIN</b>	0.725	0.652	0.605	0.530	0.512	0.387
	<b>COV [%]</b>	3.7%	6.2%	6.5%	10.9%	10.0%	10.9%
<b>OTHER BRIDGES ON THE NHS</b>	<b>AVERAGE</b>	0.906	0.840	0.777	0.827	0.893	0.694
	<b>MAX</b>	0.917	0.903	0.845	0.956	0.927	0.782
	<b>MIN</b>	0.885	0.769	0.710	0.706	0.672	0.543
	<b>COV [%]</b>	0.9%	4.8%	5.0%	8.8%	6.9%	8.0%

**Table STR-26: Normalized Shear Rating Result Statistics for Prestressed Concrete Beam/Girders, Simple Spans**

		NORMALIZED BY 3-S2			NORMALIZED BY 2-S1-2		
		Scenario #1	Scenario #2	Scenario #3	Scenario #4	Scenario #5	Scenario #6
<b>ALL BRIDGES</b>	<b>AVERAGE</b>	0.900	0.847	0.780	0.821	0.904	0.698
	<b>MAX</b>	0.917	0.914	0.846	0.906	0.956	0.800
	<b>MIN</b>	0.868	0.780	0.706	0.688	0.753	0.628
	<b>COV [%]</b>	1.3%	4.1%	4.4%	6.8%	4.5%	7.5%
<b>IHS BRIDGES</b>	<b>AVERAGE</b>	0.900	0.849	0.783	0.828	0.896	0.693
	<b>MAX</b>	0.916	0.914	0.845	0.906	0.948	0.800
	<b>MIN</b>	0.868	0.780	0.707	0.703	0.753	0.630
	<b>COV [%]</b>	1.4%	4.2%	4.7%	7.4%	5.8%	7.3%
<b>OTHER BRIDGES ON THE NHS</b>	<b>AVERAGE</b>	0.899	0.845	0.778	0.816	0.911	0.701
	<b>MAX</b>	0.917	0.914	0.846	0.906	0.956	0.799
	<b>MIN</b>	0.877	0.784	0.706	0.688	0.834	0.628
	<b>COV [%]</b>	1.3%	4.1%	4.2%	6.3%	3.3%	7.8%

**Table STR-27: Normalized Flexural Rating Result Statistics for Prestressed Concrete Beam/Girders, Continuous Spans**

		NORMALIZED BY 3-S2			NORMALIZED BY 2-S1-2		
		Scenario #1	Scenario #2	Scenario #3	Scenario #4	Scenario #5	Scenario #6
<b>ALL BRIDGES</b>	<b>AVERAGE</b>	0.907	0.859	0.797	0.851	0.855	0.677
	<b>MAX</b>	0.917	0.905	0.849	0.900	0.964	0.874
	<b>MIN</b>	0.887	0.785	0.725	0.695	0.650	0.524
	<b>COV [%]</b>	0.7%	4.2%	4.5%	6.0%	9.5%	10.8%
<b>IHS BRIDGES</b>	<b>AVERAGE</b>	0.908	0.853	0.791	0.854	0.875	0.672
	<b>MAX</b>	0.917	0.903	0.849	0.896	0.925	0.735
	<b>MIN</b>	0.887	0.785	0.725	0.695	0.650	0.524
	<b>COV [%]</b>	0.8%	4.6%	4.9%	7.0%	9.4%	8.2%
<b>OTHER BRIDGES ON THE NHS</b>	<b>AVERAGE</b>	0.906	0.861	0.800	0.850	0.845	0.680
	<b>MAX</b>	0.917	0.905	0.848	0.900	0.964	0.874
	<b>MIN</b>	0.896	0.792	0.732	0.719	0.682	0.558
	<b>COV [%]</b>	0.6%	4.0%	4.4%	5.5%	9.2%	12.0%

**Table STR-28: Normalized Shear Rating Result Statistics for Prestressed Concrete Beam/Girders, Continuous Spans**

		NORMALIZED BY 3-S2			NORMALIZED BY 2-S1-2		
		Scenario #1	Scenario #2	Scenario #3	Scenario #4	Scenario #5	Scenario #6
<b>ALL BRIDGES</b>	<b>AVERAGE</b>	0.904	0.847	0.786	0.854	0.884	0.685
	<b>MAX</b>	0.924	0.914	0.844	0.909	0.986	0.792
	<b>MIN</b>	0.892	0.799	0.740	0.758	0.727	0.601
	<b>COV [%]</b>	1.0%	3.4%	3.3%	4.5%	7.6%	6.7%
<b>IHS BRIDGES</b>	<b>AVERAGE</b>	0.904	0.848	0.787	0.851	0.879	0.676
	<b>MAX</b>	0.924	0.914	0.844	0.900	0.954	0.792
	<b>MIN</b>	0.892	0.811	0.753	0.758	0.727	0.601
	<b>COV [%]</b>	1.2%	3.7%	3.7%	5.1%	7.9%	6.9%
<b>OTHER BRIDGES ON THE NHS</b>	<b>AVERAGE</b>	0.904	0.847	0.785	0.855	0.887	0.689
	<b>MAX</b>	0.917	0.911	0.840	0.909	0.986	0.759
	<b>MIN</b>	0.892	0.799	0.740	0.781	0.756	0.624
	<b>COV [%]</b>	0.8%	3.3%	3.1%	4.3%	7.7%	6.7%

**Table STR-29: Normalized Flexural Rating Result Statistics for Steel Beam/Girder, Simple Span (L < 100 ft.)**

		NORMALIZED BY 3-S2			NORMALIZED BY 2-S1-2		
		Scenario #1	Scenario #2	Scenario #3	Scenario #4	Scenario #5	Scenario #6
<b>ALL BRIDGES</b>	<b>AVERAGE</b>	0.907	0.844	0.783	0.859	0.887	0.687
	<b>MAX</b>	0.917	0.901	0.837	0.922	0.947	0.812
	<b>MIN</b>	0.880	0.740	0.683	0.717	0.742	0.598
	<b>COV [%]</b>	0.7%	5.3%	5.5%	6.5%	5.6%	5.2%
<b>IHS BRIDGES</b>	<b>AVERAGE</b>	0.907	0.839	0.777	0.866	0.887	0.690
	<b>MAX</b>	0.916	0.895	0.834	0.922	0.925	0.812
	<b>MIN</b>	0.895	0.768	0.709	0.755	0.772	0.626
	<b>COV [%]</b>	0.6%	5.3%	5.5%	6.3%	6.0%	6.5%
<b>OTHER BRIDGES ON THE NHS</b>	<b>AVERAGE</b>	0.907	0.846	0.785	0.857	0.886	0.686
	<b>MAX</b>	0.917	0.901	0.837	0.911	0.947	0.752
	<b>MIN</b>	0.880	0.740	0.683	0.717	0.742	0.598
	<b>COV [%]</b>	0.7%	5.4%	5.6%	6.5%	5.5%	4.7%

**Table STR-30: Normalized Shear Rating Result Statistics for Steel Beam/Girder, Simple Span (L < 100 ft.)**

		NORMALIZED BY 3-S2			NORMALIZED BY 2-S1-2		
		Scenario #1	Scenario #2	Scenario #3	Scenario #4	Scenario #5	Scenario #6
<b>ALL BRIDGES</b>	<b>AVERAGE</b>	0.899	0.841	0.778	0.849	0.872	0.663
	<b>MAX</b>	0.918	0.911	0.842	0.906	0.946	0.751
	<b>MIN</b>	0.879	0.786	0.726	0.739	0.730	0.604
	<b>COV [%]</b>	1.0%	3.5%	3.5%	5.7%	7.2%	5.0%
<b>IHS BRIDGES</b>	<b>AVERAGE</b>	0.896	0.837	0.772	0.843	0.872	0.657
	<b>MAX</b>	0.904	0.893	0.815	0.901	0.941	0.726
	<b>MIN</b>	0.879	0.786	0.726	0.760	0.749	0.622
	<b>COV [%]</b>	0.7%	3.9%	3.7%	5.7%	7.6%	4.4%
<b>OTHER BRIDGES ON THE NHS</b>	<b>AVERAGE</b>	0.900	0.843	0.780	0.852	0.873	0.666
	<b>MAX</b>	0.918	0.911	0.842	0.906	0.946	0.751
	<b>MIN</b>	0.881	0.797	0.736	0.739	0.730	0.604
	<b>COV [%]</b>	1.0%	3.5%	3.4%	5.8%	7.2%	5.2%

**Table STR-31: Normalized Flexural Rating Result Statistics for Steel Beam/Girder, Simple Span  
(L > 100 ft.)**

		NORMALIZED BY 3-S2			NORMALIZED BY 2-S1-2		
		Scenario #1	Scenario #2	Scenario #3	Scenario #4	Scenario #5	Scenario #6
<b>ALL BRIDGES</b>	<b>AVERAGE</b>	0.909	0.872	0.809	0.879	0.868	0.671
	<b>MAX</b>	0.917	0.913	0.844	0.930	0.936	0.751
	<b>MIN</b>	0.893	0.775	0.716	0.760	0.685	0.552
	<b>COV [%]</b>	0.6%	3.5%	3.6%	3.7%	8.0%	6.0%
<b>IHS BRIDGES</b>	<b>AVERAGE</b>	0.910	0.874	0.810	0.878	0.872	0.671
	<b>MAX</b>	0.916	0.913	0.843	0.902	0.936	0.751
	<b>MIN</b>	0.893	0.794	0.734	0.768	0.685	0.552
	<b>COV [%]</b>	0.6%	3.4%	3.4%	3.6%	8.1%	6.5%
<b>OTHER BRIDGES ON THE NHS</b>	<b>AVERAGE</b>	0.909	0.869	0.807	0.881	0.863	0.670
	<b>MAX</b>	0.917	0.907	0.844	0.930	0.925	0.729
	<b>MIN</b>	0.899	0.775	0.716	0.760	0.745	0.614
	<b>COV [%]</b>	0.5%	3.6%	3.8%	3.9%	7.9%	5.5%

**Table STR-32: Normalized Shear Rating Result Statistics for Steel Beam/Girder, Simple Span  
(L > 100 ft.)**

		NORMALIZED BY 3-S2			NORMALIZED BY 2-S1-2		
		Scenario #1	Scenario #2	Scenario #3	Scenario #4	Scenario #5	Scenario #6
<b>ALL BRIDGES</b>	<b>AVERAGE</b>	0.905	0.846	0.785	0.864	0.878	0.676
	<b>MAX</b>	0.917	0.908	0.839	0.904	0.946	0.729
	<b>MIN</b>	0.890	0.800	0.742	0.802	0.740	0.614
	<b>COV [%]</b>	1.1%	3.9%	3.8%	3.0%	7.4%	5.2%
<b>IHS BRIDGES</b>	<b>AVERAGE</b>	0.905	0.842	0.782	0.866	0.884	0.681
	<b>MAX</b>	0.917	0.904	0.834	0.904	0.943	0.725
	<b>MIN</b>	0.890	0.800	0.742	0.825	0.740	0.614
	<b>COV [%]</b>	1.2%	4.0%	3.9%	2.6%	7.1%	5.1%
<b>OTHER BRIDGES ON THE NHS</b>	<b>AVERAGE</b>	0.905	0.850	0.789	0.863	0.871	0.671
	<b>MAX</b>	0.917	0.908	0.839	0.902	0.946	0.729
	<b>MIN</b>	0.893	0.805	0.746	0.802	0.743	0.617
	<b>COV [%]</b>	1.0%	3.9%	3.7%	3.5%	7.8%	5.3%

**Table STR-33: Normalized Flexural Rating Result Statistics for Steel Beam/Girder, Continuous Spans (L < 100 ft.)**

		NORMALIZED BY 3-S2			NORMALIZED BY 2-S1-2		
		Scenario #1	Scenario #2	Scenario #3	Scenario #4	Scenario #5	Scenario #6
<b>ALL BRIDGES</b>	<b>AVERAGE</b>	0.909	0.858	0.795	0.861	0.876	0.667
	<b>MAX</b>	0.917	0.902	0.846	0.900	0.944	0.736
	<b>MIN</b>	0.898	0.769	0.710	0.735	0.610	0.480
	<b>COV [%]</b>	0.5%	4.4%	4.6%	5.4%	9.0%	7.5%
<b>IHS BRIDGES</b>	<b>AVERAGE</b>	0.910	0.858	0.795	0.866	0.898	0.676
	<b>MAX</b>	0.917	0.899	0.830	0.900	0.938	0.710
	<b>MIN</b>	0.901	0.769	0.710	0.740	0.755	0.617
	<b>COV [%]</b>	0.5%	4.7%	4.7%	5.7%	5.3%	4.3%
<b>OTHER BRIDGES ON THE NHS</b>	<b>AVERAGE</b>	0.908	0.857	0.796	0.857	0.859	0.661
	<b>MAX</b>	0.914	0.902	0.846	0.895	0.944	0.736
	<b>MIN</b>	0.898	0.771	0.712	0.735	0.610	0.480
	<b>COV [%]</b>	0.5%	4.2%	4.6%	5.2%	10.5%	9.0%

**Table STR-34: Normalized Shear Rating Result Statistics for Steel Beam/Girder, Continuous Spans (L < 100 ft.)**

		NORMALIZED BY 3-S2			NORMALIZED BY 2-S1-2		
		Scenario #1	Scenario #2	Scenario #3	Scenario #4	Scenario #5	Scenario #6
<b>ALL BRIDGES</b>	<b>AVERAGE</b>	0.901	0.845	0.780	0.848	0.891	0.668
	<b>MAX</b>	0.918	0.907	0.838	0.909	0.950	0.732
	<b>MIN</b>	0.876	0.787	0.723	0.765	0.716	0.591
	<b>COV [%]</b>	1.2%	3.7%	3.6%	4.2%	5.7%	5.1%
<b>IHS BRIDGES</b>	<b>AVERAGE</b>	0.897	0.830	0.766	0.849	0.889	0.661
	<b>MAX</b>	0.918	0.883	0.816	0.906	0.950	0.732
	<b>MIN</b>	0.876	0.787	0.723	0.765	0.803	0.591
	<b>COV [%]</b>	1.3%	3.2%	2.9%	4.8%	5.1%	5.1%
<b>OTHER BRIDGES ON THE NHS</b>	<b>AVERAGE</b>	0.905	0.855	0.790	0.848	0.893	0.674
	<b>MAX</b>	0.917	0.907	0.838	0.909	0.947	0.728
	<b>MIN</b>	0.886	0.809	0.747	0.783	0.716	0.592
	<b>COV [%]</b>	1.0%	3.7%	3.5%	3.8%	6.3%	5.2%



**Table STR-35: Normalized Flexural Rating Result Statistics for Steel Beam/Girder, Continuous Spans (L > 100 ft.)**

		NORMALIZED BY 3-S2			NORMALIZED BY 2-S1-2		
		Scenario #1	Scenario #2	Scenario #3	Scenario #4	Scenario #5	Scenario #6
<b>ALL BRIDGES</b>	<b>AVERAGE</b>	0.910	0.852	0.790	0.861	0.864	0.665
	<b>MAX</b>	0.976	0.903	0.838	1.045	0.929	0.729
	<b>MIN</b>	0.900	0.768	0.710	0.740	0.572	0.465
	<b>COV [%]</b>	1.2%	5.0%	5.2%	7.3%	9.2%	7.3%
<b>IHS BRIDGES</b>	<b>AVERAGE</b>	0.908	0.858	0.796	0.881	0.879	0.674
	<b>MAX</b>	0.915	0.886	0.821	0.900	0.922	0.696
	<b>MIN</b>	0.904	0.801	0.740	0.814	0.808	0.649
	<b>COV [%]</b>	0.4%	3.3%	3.4%	2.8%	4.6%	2.5%
<b>OTHER BRIDGES ON THE NHS</b>	<b>AVERAGE</b>	0.910	0.850	0.788	0.854	0.859	0.662
	<b>MAX</b>	0.976	0.903	0.838	1.045	0.929	0.729
	<b>MIN</b>	0.900	0.768	0.710	0.740	0.572	0.465
	<b>COV [%]</b>	1.4%	5.4%	5.7%	8.0%	10.1%	8.2%

**Table STR-36: Normalized Shear Rating Result Statistics for Steel Beam/Girder, Continuous Spans (L > 100 ft.)**

		NORMALIZED BY 3-S2			NORMALIZED BY 2-S1-2		
		Scenario #1	Scenario #2	Scenario #3	Scenario #4	Scenario #5	Scenario #6
<b>ALL BRIDGES</b>	<b>AVERAGE</b>	0.901	0.844	0.782	0.859	0.871	0.668
	<b>MAX</b>	0.917	0.900	0.832	0.907	0.945	0.747
	<b>MIN</b>	0.881	0.795	0.732	0.752	0.716	0.592
	<b>COV [%]</b>	1.0%	3.4%	3.5%	5.0%	7.0%	5.1%
<b>IHS BRIDGES</b>	<b>AVERAGE</b>	0.902	0.845	0.786	0.880	0.855	0.660
	<b>MAX</b>	0.917	0.900	0.832	0.903	0.942	0.708
	<b>MIN</b>	0.893	0.802	0.743	0.826	0.775	0.628
	<b>COV [%]</b>	0.9%	3.5%	3.3%	3.2%	7.4%	4.7%
<b>OTHER BRIDGES ON THE NHS</b>	<b>AVERAGE</b>	0.901	0.844	0.781	0.852	0.876	0.670
	<b>MAX</b>	0.917	0.896	0.828	0.907	0.945	0.747
	<b>MIN</b>	0.881	0.795	0.732	0.752	0.716	0.592
	<b>COV [%]</b>	1.0%	3.5%	3.6%	5.1%	7.1%	5.4%

**Table STR-37: Normalized LFR Rating Factors for Girder Floorbeam Systems**

		NORMALIZED BY 3-S2			NORMALIZED BY 2-S1-2		
		Scenario #1	Scenario #2	Scenario #3	Scenario #4	Scenario #5	Scenario #6
<b>ALL BRIDGES</b>	<b>AVERAGE</b>	0.906	0.854	0.794	0.889	0.804	0.640
	<b>MAX</b>	0.915	0.891	0.823	0.912	0.923	0.704
	<b>MIN</b>	0.898	0.811	0.755	0.836	0.699	0.575
	<b>COV [%]</b>	0.7%	2.8%	2.9%	2.2%	11.4%	8.0%
<b>IHS BRIDGES</b>	<b>AVERAGE</b>	0.904	0.862	0.808	0.889	0.716	0.588
	<b>MAX</b>	0.905	0.869	0.815	0.891	0.733	0.600
	<b>MIN</b>	0.902	0.855	0.800	0.887	0.699	0.575
	<b>COV [%]</b>	0.3%	1.1%	1.3%	0.4%	3.4%	3.0%
<b>OTHER BRIDGES ON THE NHS</b>	<b>AVERAGE</b>	0.907	0.853	0.792	0.889	0.823	0.652
	<b>MAX</b>	0.915	0.891	0.823	0.912	0.923	0.704
	<b>MIN</b>	0.898	0.811	0.755	0.836	0.714	0.590
	<b>COV [%]</b>	0.8%	3.1%	3.0%	2.5%	12.5%	8.4%

NOTE: Rating factors determined based on the LFR methodology. Separate flexural/shear rating factors unavailable

**Table STR-38: Normalized Flexural Rating Result Statistics for Reinforced Concrete Tee Beams**

		NORMALIZED BY 3-S2			NORMALIZED BY 2-S1-2		
		Scenario #1	Scenario #2	Scenario #3	Scenario #4	Scenario #5	Scenario #6
<b>ALL BRIDGES</b>	<b>AVERAGE</b>	0.909	0.869	0.806	0.867	0.869	0.673
	<b>MAX</b>	0.916	1.075	1.008	0.925	0.941	0.844
	<b>MIN</b>	0.895	0.768	0.710	0.737	0.646	0.519
	<b>COV [%]</b>	0.6%	5.9%	6.2%	5.8%	8.9%	9.6%
<b>IHS BRIDGES</b>	<b>AVERAGE</b>	0.912	0.864	0.800	0.877	0.900	0.675
	<b>MAX</b>	0.916	0.921	0.860	0.920	0.924	0.722
	<b>MIN</b>	0.900	0.768	0.710	0.748	0.766	0.562
	<b>COV [%]</b>	0.4%	4.4%	4.6%	5.1%	5.1%	6.4%
<b>OTHER BRIDGES ON THE NHS</b>	<b>AVERAGE</b>	0.908	0.870	0.808	0.864	0.860	0.672
	<b>MAX</b>	0.916	1.075	1.008	0.925	0.941	0.844
	<b>MIN</b>	0.895	0.769	0.711	0.737	0.646	0.519
	<b>COV [%]</b>	0.6%	6.3%	6.6%	5.9%	9.1%	10.3%

**Table STR-39: Normalized Shear Rating Result Statistics for Reinforced Concrete Tee Beams**

		NORMALIZED BY 3-S2			NORMALIZED BY 2-S1-2		
		Scenario #1	Scenario #2	Scenario #3	Scenario #4	Scenario #5	Scenario #6
<b>ALL BRIDGES</b>	<b>AVERAGE</b>	0.903	0.852	0.790	0.854	0.880	0.677
	<b>MAX</b>	0.917	1.075	1.008	0.906	0.950	0.844
	<b>MIN</b>	0.891	0.770	0.711	0.754	0.717	0.592
	<b>COV [%]</b>	1.0%	5.9%	5.9%	4.5%	5.8%	6.4%
<b>IHS BRIDGES</b>	<b>AVERAGE</b>	0.901	0.837	0.776	0.863	0.885	0.671
	<b>MAX</b>	0.916	0.899	0.831	0.904	0.950	0.705
	<b>MIN</b>	0.894	0.801	0.742	0.810	0.822	0.641
	<b>COV [%]</b>	0.9%	3.6%	3.4%	3.2%	5.3%	3.7%
<b>OTHER BRIDGES ON THE NHS</b>	<b>AVERAGE</b>	0.903	0.856	0.793	0.852	0.879	0.679
	<b>MAX</b>	0.917	1.075	1.008	0.906	0.945	0.844
	<b>MIN</b>	0.891	0.770	0.711	0.754	0.717	0.592
	<b>COV [%]</b>	1.0%	6.5%	6.5%	4.7%	6.0%	7.1%

**Table STR-40: Normalized Flexural Rating Result Statistics for Box Beams**

		NORMALIZED BY 3-S2			NORMALIZED BY 2-S1-2		
		Scenario #1	Scenario #2	Scenario #3	Scenario #4	Scenario #5	Scenario #6
<b>ALL BRIDGES</b>	<b>AVERAGE</b>	0.909	0.867	0.807	0.871	0.834	0.640
	<b>MAX</b>	0.923	0.903	0.843	0.938	0.930	0.724
	<b>MIN</b>	0.900	0.768	0.709	0.721	0.616	0.496
	<b>COV [%]</b>	0.4%	3.5%	3.8%	4.8%	12.0%	8.9%
<b>IHS BRIDGES</b>	<b>AVERAGE</b>	0.910	0.876	0.814	0.877	0.836	0.639
	<b>MAX</b>	0.917	0.898	0.839	0.900	0.924	0.706
	<b>MIN</b>	0.905	0.847	0.783	0.858	0.629	0.513
	<b>COV [%]</b>	0.4%	1.8%	2.3%	1.8%	13.7%	10.1%
<b>OTHER BRIDGES ON THE NHS</b>	<b>AVERAGE</b>	0.909	0.865	0.805	0.870	0.834	0.640
	<b>MAX</b>	0.923	0.903	0.843	0.938	0.930	0.724
	<b>MIN</b>	0.900	0.768	0.709	0.721	0.616	0.496
	<b>COV [%]</b>	0.4%	3.7%	4.0%	5.3%	11.8%	8.7%

**Table STR-41: Normalized Shear Rating Result Statistics for Box Beams**

		NORMALIZED BY 3-S2			NORMALIZED BY 2-S1-2		
		Scenario #1	Scenario #2	Scenario #3	Scenario #4	Scenario #5	Scenario #6
<b>ALL BRIDGES</b>	<b>AVERAGE</b>	0.900	0.845	0.780	0.863	0.874	0.665
	<b>MAX</b>	0.917	0.914	0.845	0.905	0.950	0.719
	<b>MIN</b>	0.789	0.719	0.596	0.788	0.736	0.512
	<b>COV [%]</b>	2.4%	4.5%	5.5%	3.6%	6.0%	5.4%
<b>IHS BRIDGES</b>	<b>AVERAGE</b>	0.906	0.834	0.771	0.861	0.884	0.673
	<b>MAX</b>	0.917	0.886	0.819	0.901	0.932	0.711
	<b>MIN</b>	0.890	0.784	0.713	0.837	0.810	0.636
	<b>COV [%]</b>	1.2%	3.8%	4.3%	2.7%	5.2%	4.4%
<b>OTHER BRIDGES ON THE NHS</b>	<b>AVERAGE</b>	0.899	0.847	0.782	0.863	0.871	0.664
	<b>MAX</b>	0.917	0.914	0.845	0.905	0.950	0.719
	<b>MIN</b>	0.789	0.719	0.596	0.788	0.736	0.512
	<b>COV [%]</b>	2.5%	4.7%	5.8%	3.8%	6.2%	5.5%

**Table STR-42: Normalized LFR Rating Factors for *Through Trusses***

		NORMALIZED BY 3-S2			NORMALIZED BY 2-S1-2		
		Scenario #1	Scenario #2	Scenario #3	Scenario #4	Scenario #5	Scenario #6
<b>ALL BRIDGES</b>	<b>AVERAGE</b>	0.908	0.858	0.797	0.873	0.860	0.663
	<b>MAX</b>	0.916	0.898	0.830	0.908	0.924	0.731
	<b>MIN</b>	0.898	0.776	0.717	0.735	0.738	0.612
	<b>COV [%]</b>	0.7%	3.8%	3.8%	5.0%	8.4%	4.9%
<b>IHS BRIDGES</b>	<b>AVERAGE</b>	0.902	0.855	0.799	0.894	0.744	0.618
	<b>MAX</b>	0.902	0.855	0.799	0.894	0.744	0.618
	<b>MIN</b>	0.902	0.855	0.799	0.894	0.744	0.618
	<b>COV [%]</b>	N/A	N/A	N/A	N/A	N/A	N/A
<b>OTHER BRIDGES ON THE NHS</b>	<b>AVERAGE</b>	0.908	0.858	0.797	0.872	0.868	0.666
	<b>MAX</b>	0.916	0.898	0.830	0.908	0.924	0.731
	<b>MIN</b>	0.898	0.776	0.717	0.735	0.738	0.612
	<b>COV [%]</b>	0.7%	4.0%	4.0%	5.0%	9.0%	5.1%

NOTE: Rating factors determined based on the LFR methodology. N/A: Statistically not applicable (only 1 bridge).

**POSTING ANALYSIS**

**Table STR-43: Bridges with RF < 1.0 Sorted by Bridge Type**

	Bridge Type	#. of IHS Bridges Rated	# of Other NHS Bridges Rated	Vehicle Configuration	RF < 1.0 Flexure Controls	RF < 1.0 Shear Controls	Flex or Shear RF < 1.0	# of IHS Bridges w/ RF < 1.0	# of Other NHS Bridges w/ RF < 1.0	% of IHS Bridges Rated w/ RF < 1.0	% of Other NHS Bridges Rated w/ RF < 1.0
<b>1</b>	Concrete Slab	18	40	3-S2	4	0	4	2	2	11.1%	5.0%
		18	40	Scenario #1	5	0	5	2	3	11.1%	7.5%
		18	40	Scenario #2	8	0	8	2	6	11.1%	15.0%
		18	40	Scenario #3	10	0	10	2	8	11.1%	20.0%
		18	40	2-S1-2	0	0	0	0	0	0.0%	0.0%
		18	40	Scenario #4	3	0	3	2	1	11.1%	2.5%
		18	40	Scenario #5	0	0	0	0	0	0.0%	0.0%
		18	40	Scenario #6	4	0	4	2	2	11.1%	5.0%
<b>2</b>	Concrete Girder / Simple span	30	39	3-S2	1	0	1	1	0	3.3%	0.0%
		30	39	Scenario #1	1	0	1	1	0	3.3%	0.0%
		30	39	Scenario #2	1	0	1	1	0	3.3%	0.0%
		30	39	Scenario #3	2	0	2	2	0	6.7%	0.0%
		30	39	2-S1-2	1	0	1	1	0	3.3%	0.0%
		30	39	Scenario #4	1	0	1	1	0	3.3%	0.0%
		30	39	Scenario #5	1	0	1	1	0	3.3%	0.0%
		30	39	Scenario #6	2	0	2	2	0	6.7%	0.0%
<b>3</b>	Concrete Girder / Cont. spans	16	32	3-S2	1	0	1	1	0	6.3%	0.0%
		16	32	Scenario #1	1	0	1	1	0	6.3%	0.0%
		16	32	Scenario #2	2	0	2	1	1	6.3%	3.1%
		16	32	Scenario #3	2	0	2	1	1	6.3%	3.1%
		16	32	2-S1-2	1	0	1	1	0	6.3%	0.0%
		16	32	Scenario #4	2	0	2	1	1	6.3%	3.1%
		16	32	Scenario #5	2	0	2	1	1	6.3%	3.1%
		16	32	Scenario #6	2	1	3	2	1	12.5%	3.1%
<b>4</b>	Steel Girder / Simple span, L < 100	14	38	3-S2	2	0	2	0	2	0.0%	5.3%
		14	38	Scenario #1	2	0	2	0	2	0.0%	5.3%
		14	38	Scenario #2	4	0	4	0	4	0.0%	10.5%
		14	38	Scenario #3	4	0	4	0	4	0.0%	10.5%
		14	38	2-S1-2	0	0	0	0	0	0.0%	0.0%
		14	38	Scenario #4	2	0	2	0	2	0.0%	5.3%
		14	38	Scenario #5	0	0	0	0	0	0.0%	0.0%
		14	38	Scenario #6	2	0	2	0	2	0.0%	5.3%

Bridge Structure Comparative Analysis Technical Report

**Table STR-43: Bridges with RF < 1.0 Sorted by Bridge Type (continued)**

	Bridge Type	# of IHS Bridges Rated	# of Other NHS Bridges Rated	Vehicle Configuration	RF < 1.0 Flexure Controls	RF < 1.0 Shear Controls	Flex or Shear RF < 1.0	# of IHS Bridges w/ RF < 1.0	# of Other NHS Bridges w/ RF < 1.0	% of IHS Bridges Rated w/ RF < 1.0	% of Other NHS Bridges Rated w/ RF < 1.0
5	Steel Girder / Simple span, L > 100	19	17	3-S2	0	2	2	1	1	5.3%	5.9%
		19	17	Scenario #1	0	2	2	1	1	5.3%	5.9%
		19	17	Scenario #2	0	2	2	1	1	5.3%	5.9%
		19	17	Scenario #3	0	2	2	1	1	5.3%	5.9%
		19	17	2-S1-2	0	1	1	0	1	0.0%	5.9%
		19	17	Scenario #4	0	1	1	0	1	0.0%	5.9%
		19	17	Scenario #5	0	2	2	1	1	5.3%	5.9%
		19	17	Scenario #6	2	2	4	2	2	10.5%	11.8%
6	Steel Girder / Cont. spans, L < 100	21	28	3-S2	0	0	0	0	0	0.0%	0.0%
		21	28	Scenario #1	0	0	0	0	0	0.0%	0.0%
		21	28	Scenario #2	0	0	0	0	0	0.0%	0.0%
		21	28	Scenario #3	1	0	1	0	1	0.0%	3.6%
		21	28	2-S1-2	0	0	0	0	0	0.0%	0.0%
		21	28	Scenario #4	0	0	0	0	0	0.0%	0.0%
		21	28	Scenario #5	0	0	0	0	0	0.0%	0.0%
		21	28	Scenario #6	1	0	1	0	1	0.0%	3.6%
7	Steel Girder / Cont. spans, L > 100	11	33	3-S2	0	0	0	0	0	0.0%	0.0%
		11	33	Scenario #1	0	0	0	0	0	0.0%	0.0%
		11	33	Scenario #2	0	0	0	0	0	0.0%	0.0%
		11	33	Scenario #3	0	0	0	0	0	0.0%	0.0%
		11	33	2-S1-2	0	0	0	0	0	0.0%	0.0%
		11	33	Scenario #4	0	0	0	0	0	0.0%	0.0%
		11	33	Scenario #5	0	0	0	0	0	0.0%	0.0%
		11	33	Scenario #6	1	0	1	1	0	9.1%	0.0%
8	Steel Girder / Floor-beam*	2	9	3-S2	N/A	N/A	0	0	0	0.0%	0.0%
		2	9	Scenario #1	N/A	N/A	0	0	0	0.0%	0.0%
		2	9	Scenario #2	N/A	N/A	0	0	0	0.0%	0.0%
		2	9	Scenario #3	N/A	N/A	0	0	0	0.0%	0.0%
		2	9	2-S1-2	N/A	N/A	0	0	0	0.0%	0.0%
		2	9	Scenario #4	N/A	N/A	0	0	0	0.0%	0.0%
		2	9	Scenario #5	N/A	N/A	0	0	0	0.0%	0.0%
		2	9	Scenario #6	N/A	N/A	0	0	0	0.0%	0.0%
9	Conc. Tee beams	11	42	3-S2	4	2	6	0	6	0.0%	14.3%
		11	42	Scenario #1	7	4	11	0	11	0.0%	26.2%
		11	42	Scenario #2	9	5	14	0	14	0.0%	33.3%
		11	42	Scenario #3	11	6	17	1	16	9.1%	38.1%
		11	42	2-S1-2	0	0	0	0	0	0.0%	0.0%
		11	42	Scenario #4	4	1	5	0	5	0.0%	11.9%
		11	42	Scenario #5	0	1	1	0	1	0.0%	2.4%
		11	42	Scenario #6	7	5	12	1	11	9.1%	26.2%

## Bridge Structure Comparative Analysis Technical Report

**Table STR-43: Bridges with RF < 1.0 Sorted by Bridge Type (continued)**

	Bridge Type	# of IHS Bridges Rated	# of Other NHS Bridges Rated	Vehicle Configuration	RF < 1.0 Flexure Controls	RF < 1.0 Shear Controls	Flex or Shear RF < 1.0	# of IHS Bridges w/ RF < 1.0	# of Other NHS Bridges w/ RF < 1.0	% of IHS Bridges Rated w/ RF < 1.0	% of Other NHS Bridges Rated w/ RF < 1.0
<b>10</b>	Conc. Box beams	10	44	3-S2	0	0	0	0	0	0.0%	0.0%
		10	44	Scenario #1	0	0	0	0	0	0.0%	0.0%
		10	44	Scenario #2	0	0	0	0	0	0.0%	0.0%
		10	44	Scenario #3	1	0	1	0	1	0.0%	2.3%
		10	44	2-S1-2	0	0	0	0	0	0.0%	0.0%
		10	44	Scenario #4	0	0	0	0	0	0.0%	0.0%
		10	44	Scenario #5	0	0	0	0	0	0.0%	0.0%
		10	44	Scenario #6	0	0	0	0	0	0.0%	0.0%
<b>11</b>	Steel Through truss*	1	15	3-S2	Axial	Axial	0	0	0	0.0%	0.0%
		1	15	Scenario #1	Axial	Axial	0	0	0	0.0%	0.0%
		1	15	Scenario #2	Axial	Axial	0	0	0	0.0%	0.0%
		1	15	Scenario #3	Axial	Axial	0	0	0	0.0%	0.0%
		1	15	2-S1-2	Axial	Axial	0	0	0	0.0%	0.0%
		1	15	Scenario #4	Axial	Axial	0	0	0	0.0%	0.0%
		1	15	Scenario #5	Axial	Axial	0	0	0	0.0%	0.0%
		1	15	Scenario #6	Axial	Axial	0	0	0	0.0%	0.0%
TOTAL		<b>153</b>	<b>337</b>	3-S2			<b>16</b>	<b>5</b>	<b>11</b>	<b>3.3%</b>	<b>3.3%</b>
		<b>153</b>	<b>337</b>	Scenario #1			<b>22</b>	<b>5</b>	<b>17</b>	<b>3.3%</b>	<b>5.0%</b>
		<b>153</b>	<b>337</b>	Scenario #2			<b>31</b>	<b>5</b>	<b>26</b>	<b>3.3%</b>	<b>7.7%</b>
		<b>153</b>	<b>337</b>	Scenario #3			<b>39</b>	<b>7</b>	<b>32</b>	<b>4.6%</b>	<b>9.5%</b>
		<b>153</b>	<b>337</b>	2-S1-2			<b>3</b>	<b>2</b>	<b>1</b>	<b>1.3%</b>	<b>0.3%</b>
		<b>153</b>	<b>337</b>	Scenario #4			<b>14</b>	<b>4</b>	<b>10</b>	<b>2.6%</b>	<b>3.0%</b>
		<b>153</b>	<b>337</b>	Scenario #5			<b>6</b>	<b>3</b>	<b>3</b>	<b>2.0%</b>	<b>0.9%</b>
	<b>153</b>	<b>337</b>	Scenario #6			<b>29</b>	<b>10</b>	<b>19</b>	<b>6.5%</b>	<b>5.6%</b>	

N/A: Not applicable.

\*: Girder-floorbeam systems and through trusses were rated using the Load Factor Rating (LFR) methodology. All other bridge types were rated using the Load and Resistance Factor Rating (LRFR) methodology.

**Table STR-44: Bridges with RF < 1.0 Sorted by Span Length**

Span Length [ft.]	# of IHS Bridges Rated	# of Other NHS Bridges Rated	Vehicle Configuration	# of IHS Bridges w/ RF < 1.0	# of Other NHS Bridges w/ RF < 1.0	% of IHS Bridges Rated w/ RF < 1.0	% of Other NHS Bridges Rated w/ RF < 1.0
<b>&lt;20</b>	0	8	3-S2	0	0	0.0%	0.0%
	0	8	Scenario #1	0	0	0.0%	0.0%
	0	8	Scenario #2	0	1	0.0%	12.5%
	0	8	Scenario #3	0	1	0.0%	12.5%
	0	8	2-S1-2	0	0	0.0%	0.0%
	0	8	Scenario #4	0	0	0.0%	0.0%
	0	8	Scenario #5	0	0	0.0%	0.0%
	0	8	Scenario #6	0	0	0.0%	0.0%
<b>20-40</b>	24	67	3-S2	2	5	8.3%	7.5%
	24	67	Scenario #1	2	10	8.3%	14.9%
	24	67	Scenario #2	2	13	8.3%	19.4%
	24	67	Scenario #3	2	16	8.3%	23.9%
	24	67	2-S1-2	0	0	0.0%	0.0%
	24	67	Scenario #4	2	5	8.3%	7.5%
	24	67	Scenario #5	0	0	0.0%	0.0%
	24	67	Scenario #6	2	6	8.3%	9.0%
<b>40-60</b>	25	76	3-S2	1	4	4.0%	5.3%
	25	76	Scenario #1	1	5	4.0%	6.6%
	25	76	Scenario #2	1	8	4.0%	10.5%
	25	76	Scenario #3	2	10	8.0%	13.2%
	25	76	2-S1-2	1	0	4.0%	0.0%
	25	76	Scenario #4	1	2	4.0%	2.6%
	25	76	Scenario #5	1	1	4.0%	1.3%
	25	76	Scenario #6	1	7	4.0%	9.2%
<b>60-80</b>	31	59	3-S2	1	1	3.2%	1.7%
	31	59	Scenario #1	1	1	3.2%	1.7%
	31	59	Scenario #2	1	2	3.2%	3.4%
	31	59	Scenario #3	2	2	6.5%	3.4%
	31	59	2-S1-2	1	0	3.2%	0.0%
	31	59	Scenario #4	1	2	3.2%	3.4%
	31	59	Scenario #5	1	1	3.2%	1.7%
	31	59	Scenario #6	3	2	9.7%	3.4%
<b>80-100</b>	31	44	3-S2	0	0	0.0%	0.0%
	31	44	Scenario #1	0	0	0.0%	0.0%
	31	44	Scenario #2	0	1	0.0%	2.3%
	31	44	Scenario #3	0	2	0.0%	4.5%
	31	44	2-S1-2	0	0	0.0%	0.0%
	31	44	Scenario #4	0	0	0.0%	0.0%
	31	44	Scenario #5	0	0	0.0%	0.0%
	31	44	Scenario #6	1	2	3.2%	4.5%



Bridge Structure Comparative Analysis Technical Report

---

**Table STR-44: Bridges with RF < 1.0 Sorted by Span Length (continued)**

Span Length [ft.]	# of IHS Bridges Rated	# of Other NHS Bridges Rated	Vehicle Configuration	# of IHS Bridges w/ RF < 1.0	# of Other NHS Bridges w/ RF < 1.0	% of IHS Bridges Rated w/ RF < 1.0	% of Other NHS Bridges Rated w/ RF < 1.0
<b>100-120</b>	22	32	3-S2	1	1	4.5%	3.1%
	22	32	Scenario #1	1	1	4.5%	3.1%
	22	32	Scenario #2	1	1	4.5%	3.1%
	22	32	Scenario #3	1	1	4.5%	3.1%
	22	32	2-S1-2	0	1	0.0%	3.1%
	22	32	Scenario #4	0	1	0.0%	3.1%
	22	32	Scenario #5	1	1	4.5%	3.1%
	22	32	Scenario #6	1	2	4.5%	6.3%
<b>120-140</b>	14	11	3-S2	0	0	0.0%	0.0%
	14	11	Scenario #1	0	0	0.0%	0.0%
	14	11	Scenario #2	0	0	0.0%	0.0%
	14	11	Scenario #3	0	0	0.0%	0.0%
	14	11	2-S1-2	0	0	0.0%	0.0%
	14	11	Scenario #4	0	0	0.0%	0.0%
	14	11	Scenario #5	0	0	0.0%	0.0%
	14	11	Scenario #6	0	0	0.0%	0.0%
<b>140-160</b>	2	10	3-S2	0	0	0.0%	0.0%
	2	10	Scenario #1	0	0	0.0%	0.0%
	2	10	Scenario #2	0	0	0.0%	0.0%
	2	10	Scenario #3	0	0	0.0%	0.0%
	2	10	2-S1-2	0	0	0.0%	0.0%
	2	10	Scenario #4	0	0	0.0%	0.0%
	2	10	Scenario #5	0	0	0.0%	0.0%
	2	10	Scenario #6	0	0	0.0%	0.0%
<b>160-180</b>	1	6	3-S2	0	0	0.0%	0.0%
	1	6	Scenario #1	0	0	0.0%	0.0%
	1	6	Scenario #2	0	0	0.0%	0.0%
	1	6	Scenario #3	0	0	0.0%	0.0%
	1	6	2-S1-2	0	0	0.0%	0.0%
	1	6	Scenario #4	0	0	0.0%	0.0%
	1	6	Scenario #5	0	0	0.0%	0.0%
	1	6	Scenario #6	1	0	100.0%	0.0%
<b>180-200</b>	1	1	3-S2	0	0	0.0%	0.0%
	1	1	Scenario #1	0	0	0.0%	0.0%
	1	1	Scenario #2	0	0	0.0%	0.0%
	1	1	Scenario #3	0	0	0.0%	0.0%
	1	1	2-S1-2	0	0	0.0%	0.0%
	1	1	Scenario #4	0	0	0.0%	0.0%
	1	1	Scenario #5	0	0	0.0%	0.0%
	1	1	Scenario #6	1	0	100.0%	0.0%

**Table STR-44: Bridges with RF < 1.0 Sorted by Span Length (continued)**

## Bridge Structure Comparative Analysis Technical Report

---

Span Length [ft.]	# of IHS Bridges Rated	# of Other NHS Bridges Rated	Vehicle Configuration	# of IHS Bridges w/ RF < 1.0	# of Other NHS Bridges w/ RF < 1.0	% of IHS Bridges Rated w/ RF < 1.0	% of Other NHS Bridges Rated w/ RF < 1.0
<b>&gt;200</b>	2	23	3-S2	0	0	0.0%	0.0%
	2	23	Scenario #1	0	0	0.0%	0.0%
	2	23	Scenario #2	0	0	0.0%	0.0%
	2	23	Scenario #3	0	0	0.0%	0.0%
	2	23	2-S1-2	0	0	0.0%	0.0%
	2	23	Scenario #4	0	0	0.0%	0.0%
	2	23	Scenario #5	0	0	0.0%	0.0%
2	23	Scenario #6	0	0	0.0%	0.0%	
<b>TOTAL</b>	<b>153</b>	<b>337</b>	3-S2	<b>5</b>	<b>11</b>	<b>3.3%</b>	<b>3.3%</b>
	<b>153</b>	<b>337</b>	Scenario #1	<b>5</b>	<b>17</b>	<b>3.3%</b>	<b>5.0%</b>
	<b>153</b>	<b>337</b>	Scenario #2	<b>5</b>	<b>26</b>	<b>3.3%</b>	<b>7.7%</b>
	<b>153</b>	<b>337</b>	Scenario #3	<b>7</b>	<b>32</b>	<b>4.6%</b>	<b>9.5%</b>
	<b>153</b>	<b>337</b>	2-S1-2	<b>2</b>	<b>1</b>	<b>1.3%</b>	<b>0.3%</b>
	<b>153</b>	<b>337</b>	Scenario #4	<b>4</b>	<b>10</b>	<b>2.6%</b>	<b>3.0%</b>
	<b>153</b>	<b>337</b>	Scenario #5	<b>3</b>	<b>3</b>	<b>2.0%</b>	<b>0.9%</b>
<b>153</b>	<b>337</b>	Scenario #6	<b>10</b>	<b>19</b>	<b>6.5%</b>	<b>5.6%</b>	

**Table STR-45: Bridges with RF < 1.0 Sorted by Year Built**

Year Built	# of IHS Bridges Rated	# of Other NHS Bridges Rated	Vehicle Configuration	# of IHS Bridges w/ RF < 1.0	# of Other NHS Bridges w/ RF < 1.0	% of IHS Bridges Rated w/ RF < 1.0	% of Other NHS Bridges Rated w/ RF < 1.0
<b>&lt;1920</b>	0	2	3-S2	0	0	0.0%	0.0%
	0	2	Scenario #1	0	0	0.0%	0.0%
	0	2	Scenario #2	0	1	0.0%	50.0%
	0	2	Scenario #3	0	1	0.0%	50.0%
	0	2	2-S1-2	0	0	0.0%	0.0%
	0	2	Scenario #4	0	0	0.0%	0.0%
	0	2	Scenario #5	0	0	0.0%	0.0%
	0	2	Scenario #6	0	0	0.0%	0.0%
<b>1920-1930</b>	0	20	3-S2	0	2	0.0%	10.0%
	0	20	Scenario #1	0	2	0.0%	10.0%
	0	20	Scenario #2	0	3	0.0%	15.0%
	0	20	Scenario #3	0	4	0.0%	20.0%
	0	20	2-S1-2	0	0	0.0%	0.0%
	0	20	Scenario #4	0	2	0.0%	10.0%
	0	20	Scenario #5	0	0	0.0%	0.0%
	0	20	Scenario #6	0	2	0.0%	10.0%
<b>1930-1940</b>	0	42	3-S2	0	3	0.0%	7.1%
	0	42	Scenario #1	0	6	0.0%	14.3%
	0	42	Scenario #2	0	9	0.0%	21.4%
	0	42	Scenario #3	0	10	0.0%	23.8%
	0	42	2-S1-2	0	0	0.0%	0.0%
	0	42	Scenario #4	0	3	0.0%	7.1%
	0	42	Scenario #5	0	0	0.0%	0.0%
	0	42	Scenario #6	0	6	0.0%	14.3%
<b>1940-1950</b>	0	21	3-S2	0	0	0.0%	0.0%
	0	21	Scenario #1	0	1	0.0%	4.8%
	0	21	Scenario #2	0	1	0.0%	4.8%
	0	21	Scenario #3	0	3	0.0%	14.3%
	0	21	2-S1-2	0	0	0.0%	0.0%
	0	21	Scenario #4	0	0	0.0%	0.0%
	0	21	Scenario #5	0	0	0.0%	0.0%
	0	21	Scenario #6	0	2	0.0%	9.5%
<b>1950-1960</b>	21	41	3-S2	0	2	0.0%	4.9%
	21	41	Scenario #1	0	2	0.0%	4.9%
	21	41	Scenario #2	0	5	0.0%	12.2%
	21	41	Scenario #3	1	6	4.8%	14.6%
	21	41	2-S1-2	0	0	0.0%	0.0%
	21	41	Scenario #4	0	1	0.0%	2.4%
	21	41	Scenario #5	0	1	0.0%	2.4%
	21	41	Scenario #6	1	4	4.8%	9.8%

Bridge Structure Comparative Analysis Technical Report

---

**Table STR-45: Bridges with RF < 1.0 Sorted by Year Built** *(continued)*

Year Built	# of IHS Bridges Rated	# of Other NHS Bridges Rated	Vehicle Configuration	# of IHS Bridges w/ RF < 1.0	# of Other NHS Bridges w/ RF < 1.0	% of IHS Bridges Rated w/ RF < 1.0	% of Other NHS Bridges Rated w/ RF < 1.0
<b>1960-1970</b>	58	45	3-S2	4	2	6.9%	4.4%
	58	45	Scenario #1	4	2	6.9%	4.4%
	58	45	Scenario #2	4	2	6.9%	4.4%
	58	45	Scenario #3	4	2	6.9%	4.4%
	58	45	2-S1-2	1	1	1.7%	2.2%
	58	45	Scenario #4	3	1	5.2%	2.2%
	58	45	Scenario #5	2	1	3.4%	2.2%
	58	45	Scenario #6	5	2	8.6%	4.4%
<b>1970-1980</b>	35	37	3-S2	0	0	0.0%	0.0%
	35	37	Scenario #1	0	1	0.0%	2.7%
	35	37	Scenario #2	0	1	0.0%	2.7%
	35	37	Scenario #3	0	1	0.0%	2.7%
	35	37	2-S1-2	0	0	0.0%	0.0%
	35	37	Scenario #4	0	0	0.0%	0.0%
	35	37	Scenario #5	0	0	0.0%	0.0%
	35	37	Scenario #6	0	0	0.0%	0.0%
<b>1980-1990</b>	18	38	3-S2	1	0	5.6%	0.0%
	18	38	Scenario #1	1	1	5.6%	2.6%
	18	38	Scenario #2	1	2	5.6%	5.3%
	18	38	Scenario #3	2	3	11.1%	7.9%
	18	38	2-S1-2	1	0	5.6%	0.0%
	18	38	Scenario #4	1	2	5.6%	5.3%
	18	38	Scenario #5	1	1	5.6%	2.6%
	18	38	Scenario #6	3	1	16.7%	2.6%
<b>1990-2000</b>	11	40	3-S2	0	2	0.0%	5.0%
	11	40	Scenario #1	0	2	0.0%	5.0%
	11	40	Scenario #2	0	2	0.0%	5.0%
	11	40	Scenario #3	0	2	0.0%	5.0%
	11	40	2-S1-2	0	0	0.0%	0.0%
	11	40	Scenario #4	0	1	0.0%	2.5%
	11	40	Scenario #5	0	0	0.0%	0.0%
	11	40	Scenario #6	0	2	0.0%	5.0%
<b>&gt;2000</b>	10	51	3-S2	0	0	0.0%	0.0%
	10	51	Scenario #1	0	0	0.0%	0.0%
	10	51	Scenario #2	0	0	0.0%	0.0%
	10	51	Scenario #3	0	0	0.0%	0.0%
	10	51	2-S1-2	0	0	0.0%	0.0%
	10	51	Scenario #4	0	0	0.0%	0.0%
	10	51	Scenario #5	0	0	0.0%	0.0%
	10	51	Scenario #6	1	0	10.0%	0.0%

**Table STR-45: Bridges with RF < 1.0 Sorted by Year Built** *(continued)*

Year Built	# of IHS Bridges Rated	# of Other NHS Bridges Rated	Vehicle Configuration	# of IHS Bridges w/ RF < 1.0	# of Other NHS Bridges w/ RF < 1.0	% of IHS Bridges Rated w/ RF < 1.0	% of Other NHS Bridges Rated w/ RF < 1.0
TOTAL	153	337	3-S2	5	11	3.3%	3.3%
	153	337	Scenario #1	5	17	3.3%	5.0%
	153	337	Scenario #2	5	26	3.3%	7.7%
	153	337	Scenario #3	7	32	4.6%	9.5%
	153	337	2-S1-2	2	1	1.3%	0.3%
	153	337	Scenario #4	4	10	2.6%	3.0%
	153	337	Scenario #5	3	3	2.0%	0.9%
	153	337	Scenario #6	10	19	6.5%	5.6%

**Table STR-46: Posting Projections**

		LOAD RATING RESULTS					PROJECTED NUMBER OF BRIDGES WITH POSTING ISSUES FOR ENTIRE INVENTORY	
	Bridge Type	#. of IHS Bridges Rated	# of Other NHS Bridges Rated	Vehicle Configuration	% of IHS Bridges Rated w/ RF < 1.0	% of Other NHS Bridges Rated w/ RF < 1.0	#. of IHS Bridges with Posting Issues	# of Other NHS Bridges with Posting Issues
1	Concrete Slab	18	40	3-S2	11.1%	5.0%	566	245
		18	40	Scenario #1	11.1%	7.5%	566	368
		18	40	Scenario #2	11.1%	15.0%	566	735
		18	40	Scenario #3	11.1%	20.0%	566	981
		18	40	2-S1-2	0.0%	0.0%	0	0
		18	40	Scenario #4	11.1%	2.5%	566	123
		18	40	Scenario #5	0.0%	0.0%	0	0
		18	40	Scenario #6	11.1%	5.0%	566	245
2	Concrete Girder / Simple span	30	39	3-S2	3.3%	0.0%	310	0
		30	39	Scenario #1	3.3%	0.0%	310	0
		30	39	Scenario #2	3.3%	0.0%	310	0
		30	39	Scenario #3	6.7%	0.0%	629	0
		30	39	2-S1-2	3.3%	0.0%	310	0
		30	39	Scenario #4	3.3%	0.0%	310	0
		30	39	Scenario #5	3.3%	0.0%	310	0
		30	39	Scenario #6	6.7%	0.0%	629	0
3	Concrete Girder / Cont. spans	16	32	3-S2	6.3%	0.0%	134	0
		16	32	Scenario #1	6.3%	0.0%	134	0
		16	32	Scenario #2	6.3%	3.1%	134	118
		16	32	Scenario #3	6.3%	3.1%	134	118
		16	32	2-S1-2	6.3%	0.0%	134	0
		16	32	Scenario #4	6.3%	3.1%	134	118
		16	32	Scenario #5	6.3%	3.1%	134	118
		16	32	Scenario #6	12.5%	3.1%	266	118
4	Steel Girder / Simple span, L < 100	14	38	3-S2	0.0%	5.3%	0	275
		14	38	Scenario #1	0.0%	5.3%	0	275
		14	38	Scenario #2	0.0%	10.5%	0	545
		14	38	Scenario #3	0.0%	10.5%	0	545
		14	38	2-S1-2	0.0%	0.0%	0	0
		14	38	Scenario #4	0.0%	5.3%	0	275
		14	38	Scenario #5	0.0%	0.0%	0	0
		14	38	Scenario #6	0.0%	5.3%	0	275

**Table STR-46: Posting Projections (continued)**

		LOAD RATING RESULTS					PROJECTED NUMBER OF BRIDGES WITH POSTING ISSUES FOR ENTIRE INVENTORY	
	Bridge Type	#. of IHS Bridges Rated	# of Other NHS Bridges Rated	Vehicle Configuration	% of IHS Bridges Rated w/ RF < 1.0	% of Other NHS Bridges Rated w/ RF < 1.0	#. of IHS Bridges with Posting Issues	# of Other NHS Bridges with Posting Issues
5	Steel Girder / Simple span, L > 100	19	17	3-S2	5.3%	5.9%	151	117
		19	17	Scenario #1	5.3%	5.9%	151	117
		19	17	Scenario #2	5.3%	5.9%	151	117
		19	17	Scenario #3	5.3%	5.9%	151	117
		19	17	2-S1-2	0.0%	5.9%	0	117
		19	17	Scenario #4	0.0%	5.9%	0	117
		19	17	Scenario #5	5.3%	5.9%	151	117
		19	17	Scenario #6	10.5%	11.8%	299	234
6	Steel Girder / Cont. spans, L < 100	21	28	3-S2	0.0%	0.0%	0	0
		21	28	Scenario #1	0.0%	0.0%	0	0
		21	28	Scenario #2	0.0%	0.0%	0	0
		21	28	Scenario #3	0.0%	3.6%	0	142
		21	28	2-S1-2	0.0%	0.0%	0	0
		21	28	Scenario #4	0.0%	0.0%	0	0
		21	28	Scenario #5	0.0%	0.0%	0	0
		21	28	Scenario #6	0.0%	3.6%	0	142
7	Steel Girder / Cont. spans, L > 100	11	33	3-S2	0.0%	0.0%	0	0
		11	33	Scenario #1	0.0%	0.0%	0	0
		11	33	Scenario #2	0.0%	0.0%	0	0
		11	33	Scenario #3	0.0%	0.0%	0	0
		11	33	2-S1-2	0.0%	0.0%	0	0
		11	33	Scenario #4	0.0%	0.0%	0	0
		11	33	Scenario #5	0.0%	0.0%	0	0
		11	33	Scenario #6	9.1%	0.0%	387	0
8	Steel Girder / Floorbeam*	2	9	3-S2	0.0%	0.0%	0	0
		2	9	Scenario #1	0.0%	0.0%	0	0
		2	9	Scenario #2	0.0%	0.0%	0	0
		2	9	Scenario #3	0.0%	0.0%	0	0
		2	9	2-S1-2	0.0%	0.0%	0	0
		2	9	Scenario #4	0.0%	0.0%	0	0
		2	9	Scenario #5	0.0%	0.0%	0	0
		2	9	Scenario #6	0.0%	0.0%	0	0

**Table STR-46: Posting Projections (continued)**

		LOAD RATING RESULTS					PROJECTED NUMBER OF BRIDGES WITH POSTING ISSUES FOR ENTIRE INVENTORY	
	Bridge Type	#. of IHS Bridges Rated	# of Other NHS Bridges Rated	Vehicle Configuration	% of IHS Bridges Rated w/ RF < 1.0	% of Other NHS Bridges Rated w/ RF < 1.0	#. of IHS Bridges with Posting Issues	# of Other NHS Bridges with Posting Issues
9	Conc. Tee beams	11	42	3-S2	0.0%	14.3%	0	500
		11	42	Scenario #1	0.0%	26.2%	0	917
		11	42	Scenario #2	0.0%	33.3%	0	1165
		11	42	Scenario #3	9.1%	38.1%	240	1333
		11	42	2-S1-2	0.0%	0.0%	0	0
		11	42	Scenario #4	0.0%	11.9%	0	416
		11	42	Scenario #5	0.0%	2.4%	0	84
10	Conc. Box beams	10	44	3-S2	0.0%	0.0%	0	0
		10	44	Scenario #1	0.0%	0.0%	0	0
		10	44	Scenario #2	0.0%	0.0%	0	0
		10	44	Scenario #3	0.0%	2.3%	0	117
		10	44	2-S1-2	0.0%	0.0%	0	0
		10	44	Scenario #4	0.0%	0.0%	0	0
		10	44	Scenario #5	0.0%	0.0%	0	0
11	Steel Through Truss*	1	15	3-S2	0.0%	0.0%	0	0
		1	15	Scenario #1	0.0%	0.0%	0	0
		1	15	Scenario #2	0.0%	0.0%	0	0
		1	15	Scenario #3	0.0%	0.0%	0	0
		1	15	2-S1-2	0.0%	0.0%	0	0
		1	15	Scenario #4	0.0%	0.0%	0	0
		1	15	Scenario #5	0.0%	0.0%	0	0
<b>TOTAL</b>		<b>153</b>	<b>337</b>	<b>3-S2</b>	<b>3.3%</b>	<b>3.3%</b>	<b>1485</b>	<b>1419</b>
		<b>153</b>	<b>337</b>	Scenario #1	<b>3.3%</b>	<b>5.0%</b>	<b>1485</b>	<b>2194</b>
		<b>153</b>	<b>337</b>	Scenario #2	<b>3.3%</b>	<b>7.7%</b>	<b>1485</b>	<b>3360</b>
		<b>153</b>	<b>337</b>	Scenario #3	<b>4.6%</b>	<b>9.5%</b>	<b>2080</b>	<b>4135</b>
		<b>153</b>	<b>337</b>	2-S1-2	<b>1.3%</b>	<b>0.3%</b>	<b>595</b>	<b>131</b>
		<b>153</b>	<b>337</b>	Scenario #4	<b>2.6%</b>	<b>3.0%</b>	<b>1185</b>	<b>1293</b>
		<b>153</b>	<b>337</b>	Scenario #5	<b>2.0%</b>	<b>0.9%</b>	<b>890</b>	<b>387</b>
		<b>153</b>	<b>337</b>	Scenario #6	<b>6.5%</b>	<b>5.6%</b>	<b>2970</b>	<b>2455</b>

\*: Girder-Floorbeam systems and through trusses were rated using the Load Factor Rating (LFR) methodology. All other bridge types were rated using the Load and Resistance Factor Rating (LRFR) methodology.